



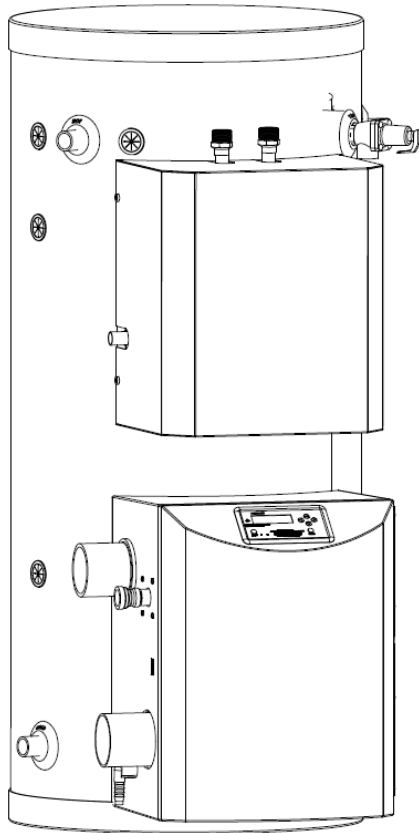
# Versa-Hydro

**INSTALLATION**

**START-UP**

**MAINTENANCE**

**PARTS**



**Versa-Hydro Appliance Models\***  
**PHE130-55 / 199-55**  
**PHE130-80 / 199-80**  
**PHE130-119 / 199-119**

\*A suffix of "LP" denotes propane gas  
"S" indicates solar models  
"SNHX" indicates solar models without heat exchanger



## **⚠ DANGER**

This manual must only be used by a qualified heating installer/service technician. Read and understand all instructions in this manual before installing. Perform steps in the order given. Failure to comply will result in substantial property damage, severe personal injury, or death.

**NOTICE:** HTP reserves the right to make product changes or updates without notice and will not be held liable for typographical errors in literature.

The surfaces of these products contacted by consumable water contain less than 0.25% lead by weight, as required by the Safe Drinking Water Act, Section 1417.

**NOTE TO CONSUMER: PLEASE KEEP ALL INSTRUCTIONS FOR FUTURE REFERENCE.**

## ⚠ WARNING

**IF THE INFORMATION IN THIS MANUAL IS NOT FOLLOWED EXACTLY, A FIRE OR EXPLOSION MAY RESULT, CAUSING PROPERTY DAMAGE, PERSONAL INJURY, OR LOSS OF LIFE. DO NOT STORE GASOLINE OR OTHER FLAMMABLE VAPORS AND LIQUIDS IN THE VICINITY OF THIS OR ANY OTHER APPLIANCE.**

### WHAT TO DO IF YOU SMELL GAS

- Do not try to light any appliance.
- Do not touch any electrical switch.
- Do not use any phone in your building.
- Immediately call your gas supplier from a neighbor's phone. Follow the gas supplier's instructions.
- If you cannot reach your gas supplier, call the fire department. Installation and service must be provided by a qualified installer, service agency, or the gas supplier.

## FOR YOUR SAFETY READ BEFORE OPERATING

**WARNING: If you do not follow these instructions exactly, a fire or explosion may result, causing property damage, personal injury or loss of life.**

- A.** This appliance does not have a pilot. It is equipped with an ignition device which automatically lights the burner. Do **not** try to light the burner by hand.
- B.** BEFORE OPERATING smell all around the appliance area for gas. Be sure to smell next to the floor because some gas is heavier than air and will settle on the floor.
- C.** Use **only** your hand to turn the gas control knob. Never use tools. If the handle will not turn by hand, don't try to repair it, call a qualified service technician. Force or attempted repair may result in a fire or explosion.

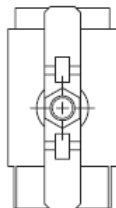
### WHAT TO DO IF YOU SMELL GAS

- Do not try to light any appliance
- Do not touch any electric switch; do not use any phone in your building
- Immediately call your gas supplier from a neighbor's phone. Follow the gas suppliers' instructions.
- If you cannot reach your gas supplier, call the fire department.
- Do not use this appliance if any part has been under water. Immediately call a qualified service technician to inspect the appliance and to replace any part of the control system and any gas control which has been under water.

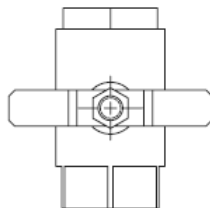
## OPERATING INSTRUCTIONS

1. STOP! Read the safety information above.
2. Set the thermostat to lowest setting.
3. Turn off all electric power to the appliance.
4. This appliance is equipped with an ignition device which automatically lights the burner. Do not try to light the burner by hand.
5. Remove front cover.
6. Turn gas shutoff valve to "off". Handle will be across the piping, do not force.
7. Wait five (5) minutes to clear out any gas. If you then smell gas, STOP! Follow "B" in the safety information above on this label. If you don't smell gas, go to next step.
8. Turn gas shutoff valve to "on". Handle will be in line with piping.
9. Install Front Cover.
10. Turn on all electric power to appliance.
11. Set thermostat to desired setting.
12. If the appliance will not operate, follow the instructions "To Turn Off Gas To Appliance" and call your service technician or gas supplier.

GAS VALVE  
ON



GAS VALVE  
OFF



## TO TURN OFF GAS TO APPLIANCE

1. Set the thermostat to lowest setting.
2. Turn off all electric power to the appliance if service is to be performed.
3. Remove Front Cover.
4. Turn gas shutoff valve to "off". Handle will be across the piping. Do not force.
5. Install Front Cover.

LP-175 Rev. 4 3-11-08

## SPECIAL ATTENTION BOXES

The following defined terms are used throughout this manual to bring attention to the presence of hazards of various risk levels or to important product information.

### **DANGER**

**DANGER** indicates an imminently hazardous situation which, if not avoided, will result in death or serious injury.

### **WARNING**

**WARNING** indicates a potentially hazardous situation which, if not avoided, could result in death or serious injury.

### **CAUTION**

**CAUTION** indicates a potentially hazardous situation which, if not avoided, may result in minor or moderate injury.

### **CAUTION**

**CAUTION** used without the safety alert symbol indicates a potentially hazardous situation which, if not avoided, may result in property damage.

## FOREWORD

This manual is intended to be used in conjunction with other literature provided with the appliance. This includes all related control information. It is important that this manual, all other documents included with this system, and additional publications including the National Fuel Gas Code, ANSI Z223.1-2002, be reviewed in their entirety before beginning any work.

Installation should be made in accordance with the regulations of the Authority Having Jurisdiction, local code authorities, and utility companies which pertain to this type of water heating equipment.

**Authority Having Jurisdiction (AHJ)** – The Authority Having Jurisdiction may be a federal, state, local government, or individual such as a fire chief, fire marshal, chief of a fire prevention bureau, labor department or health department, building official or electrical inspector, or *others having statutory authority*. In some circumstances, the property owner or his/her agent assumes the role, and at government installations, the commanding officer or departmental official may be the AHJ.

**NOTE:** HTP, Inc. reserves the right to modify product technical specifications and components without prior notice.

## FOR THE INSTALLER

### **DANGER**

This manual must only be used by a qualified heating installer/service technician. Read and understand all instructions in this manual before installing. Perform steps in the order given. Failure to comply will result in substantial property damage, severe personal injury, or death.

This appliance must be installed by qualified and licensed personnel. The installer should be guided by the instructions furnished with the appliance, and with local codes and utility company requirements. In the absence of local codes, preference should be given to the National Fuel Gas Code, ANSI Z223.1-2002.

#### **INSTALLATIONS MUST COMPLY WITH:**

Local, state, provincial, and national codes, laws, regulations and ordinances.

The latest version of the National Fuel Gas Code, ANSI Z223.1, from American Gas Association Laboratories, 8501 East Pleasant Valley Road, Cleveland, OH 44131.

In Canada – CGA No. B149 (latest version), from Canadian Gas Association Laboratories, 55 Scarsdale Road, Don Mills, Ontario, Canada M3B 2R3. Also, Canadian Electrical Code C 22.1, from Canadian Standards Association, 5060 Spectrum Way, Suite 100, Mississauga, Ontario, Canada L4W 5N6.

Code for the installation of Heat Producing Appliances (latest version), from American Insurance Association, 85 John Street, New York, NY 11038.

The latest version of the National Electrical Code, NFPA No. 70.

**NOTE:** The gas manifold and controls met safe lighting and other performance criteria when undergoing tests specified in ANSI Z21.10.3 – latest edition.

**TABLE OF CONTENTS**

**PART 1 – GENERAL SAFETY INFORMATION .....6**

- A. PRECAUTIONS .....6
- B. IMPROPER COMBUSTION.....6
- C. GAS .....7
- D. WHEN SERVICING THE APPLIANCE .....7
- E. APPLIANCE WATER .....7

**PART 2 – BEFORE YOU START .....7**

- A. WHAT’S IN THE BOX .....7
- B. HOW THE APPLIANCE OPERATES.....7
- C. OPTIONAL EQUIPMENT .....9

**PART 3 – PREPARE APPLIANCE LOCATION .....9**

- A. BEFORE LOCATING THE APPLIANCE .....9
- B. LEVELING .....10
- C. CLEARANCES FOR SERVICE ACCESS.....10
- D. RESIDENTIAL GARAGE INSTALLATION.....11
- E. EXHAUST VENT AND INTAKE PIPE .....11
  - 1. DIRECT VENT INSTALLATION OF EXHAUST VENT AND INTAKE PIPE .....11
  - 2. INDOOR COMBUSTION AIR INSTALLATION IN CONFINED OR UNCONFINED SPACE .....11
- F. PREVENT COMBUSTION AIR CONTAMINATION .....12
- G. REMOVING AN APPLIANCE FROM A COMMON VENT SYSTEM .....12
- H. WATER CHEMISTRY .....13

**PART 4 - DOMESTIC WATER PIPING .....16**

- A. TEMPERATURE AND PRESSURE RELIEF VALVE FOR DHW .....16
- B. DOMESTIC HOT WATER EXPANSION TANK .....16
- C. DOMESTIC WATER PIPING .....17
- D. APPLIANCE PIPING.....17
- E. MIXING VALVE INSTALLATION .....17
- F. AUXILIARY PIPING .....19

**PART 5 - HYDRONIC PIPING .....20**

- A. HYDRONIC HEATING MODULE PIPING.....20
- B. PRESSURE RELIEF VALVE FOR THE HYDRONIC SYSTEM.....20
- C. HYDRONIC EXPANSION TANK AND MAKE UP WATER.....20
- D. HYDRONIC HEATING MODULE SYSTEM PIPING.....20
- E. HYDRONIC HEATING MODULE OUTPUT .....21

- F. HYDRONIC PIPING ..... 24
- PART 6 - VENTING, COMBUSTION AIR AND CONDENSATE REMOVAL ..... 29**
- A. GENERAL ..... 29
- B. APPROVED MATERIALS FOR EXHAUST VENT AND INTAKE PIPE ..... 30
- C. REQUIREMENTS FOR INSTALLATION IN CANADA ..... 30
- D. EXHAUST VENT AND INTAKE PIPE LOCATION ..... 31
- E. EXHAUST VENT AND INTAKE PIPE SIZING ..... 32
- F. LONGER VENT RUNS ..... 32
- G. EXHAUST VENT AND INTAKE PIPE INSTALLATION ..... 33
- H. VENTING DRAWINGS ..... 34
- 1. DIRECT VENT INSTALLATION OF EXHAUST VENT AND INTAKE PIPE ..... 34
- 2. VENTING THROUGH AN EXISTING SYSTEM ..... 37
- 3. INDOOR COMBUSTION AIR INSTALLATION IN CONFINED OR UNCONFINED SPACE ..... 39
- I. CONDENSATE REMOVAL SYSTEM ..... 41
- PART 7 - FIELD WIRING ..... 42**
- A. FIELD WIRING COMPLIANCE REQUIREMENTS ..... 42
- B. FIELD WIRING ..... 42
- C. LINE VOLTAGE WIRING ..... 42
- D. LOW VOLTAGE WIRING ..... 42
- E. FIELD CONNECTION BOARD ..... 42
- F. INTERNAL WIRING ..... 44
- PART 8 - GAS CONNECTION ..... 46**
- A. GAS SUPPLY ..... 46
- B. GAS PIPING ..... 46
- C. GAS TABLE ..... 46
- D. GAS VALVE ..... 47
- E. HOW TO VERIFY COMBUSTION ..... 48
- PART 9 - START-UP PROCEDURE ..... 48**
- A. FILL AND PURGE DHW ..... 48
- B. FILL AND PURGE HYDRONIC HEATING LOOP ..... 49
- C. PURGE AIR FROM HYDRONIC HEATING MODULE ..... 49
- D. APPLIANCE PUMP CONTROL TO ASSIST IN PURGING AIR FROM SYSTEM LOOPS ..... 50
- E. PROGRAMMING THE TOTAL SYSTEM CONTROL ..... 50
- PART 10 - CONTROL OVERVIEW ..... 52**
- A. NAVIGATION OF THE DISPLAY ..... 52
- B. PROGRAMMING THE CONTROL ..... 53
- C. APPLIANCE SETTING PROGRAM NAVIGATION MENU ..... 53
- D. PROGRAMMING THE SYSTEM SETTING ..... 54
- E. SYSTEM SETTING PROGRAM NAVIGATION ..... 54
- F. CONTROL STATUS MENU ..... 55
- G. RESETTING THE MAINTENANCE SCHEDULE ..... 56

**PART 11 - SHUTDOWN .....57**

A. SHUTDOWN PROCEDURE ..... 57

B. VACATION PROCEDURE ..... 57

C. FAILURE TO OPERATE..... 57

**PART 12 - TROUBLESHOOTING .....57**

A. APPLIANCE ERROR CODE..... 57

B. APPLIANCE ERROR ..... 57

C. APPLIANCE FAULT ..... 57

D. APPLIANCE CONTROL FAULT CODES ..... 57

**PART 13 – MAINTENANCE .....65**

MAINTENANCE NOTES ..... 68

HTP CUSTOMER INSTALLATION RECORD FORM ..... 69

**PART 1 – GENERAL SAFETY INFORMATION**

**A. PRECAUTIONS**

This appliance is for indoor installations only. Clearance to combustible materials: 0” top, bottom, sides and back. Unit must have room for service: 24” front and 12” sides are minimum recommended service clearances. (A combustible door or removable panel is acceptable front clearance.) This appliance has been approved for closet installation. Do not install this appliance directly on carpeting. For installation on combustible flooring. Use only Category IV vent systems.

<b>⚠ WARNING</b>
<b>INSTALLER –</b> Read all instructions in this manual before installing. Perform steps in the order given.
<b>USER –</b> This manual is for use only by a qualified heating installer/service technician. Have this appliance serviced/inspected by a qualified service technician annually.
<b>FAILURE TO ADHERE TO THE GUIDELINES ON THIS PAGE AND HAVE THIS APPLIANCE SERVICED/INSPECTED ANNUALLY CAN RESULT IN SUBSTANTIAL PROPERTY DAMAGE, SEVERE PERSONAL INJURY, OR DEATH.</b>

<b>⚠ WARNING</b>
<b>NOTE:</b> If the appliance is exposed to the following, do not operate until all corrective steps have been made by a qualified serviceman:
1. FIRE
2. DAMAGE
3. WATER
Any claims for damage or shortage in shipment must be filed immediately against the transportation company by the consignee.

<b>⚠ WARNING</b>
<b>DO NOT USE THIS APPLIANCE IF ANY PART HAS BEEN SUBMERGED IN WATER.</b> Immediately call a qualified service technician. The appliance <b>MUST BE</b> replaced if it has been submerged. Attempting to operate an appliance that has been submerged could create numerous harmful conditions, such as a potential gas leakage causing a fire and/or explosion, or the release of mold, bacteria, or other harmful particulates into the air. Operating a previously submerged appliance could result in property damage, severe personal injury, or death.
<b>NOTE:</b> Appliance damage due to flood or submersion is considered an Act of God, and IS NOT covered under product warranty.

**B. IMPROPER COMBUSTION**

<b>CAUTION</b>
Do not obstruct the flow of combustion and ventilating air. Adequate air is necessary for safe operation. Failure to keep the vent and combustion air intake clear of ice, snow, or other debris could result in property damage, serious personal injury, or death.

### **C. GAS**

Should overheating occur or gas supply fail to shut off, do not turn off or disconnect electrical supply to circulator. Instead, shut off the gas supply at a location external to the appliance.

### **D. WHEN SERVICING THE APPLIANCE**

- To avoid electric shock, disconnect electrical supply before performing maintenance.
- To avoid severe burns, allow appliance to cool.

<p><b>⚠ DANGER</b></p> <p><b>Flammable Vapors</b></p>	<p><b>⚠ DANGER</b></p> <p><b>HOT</b></p> <p><b>BURN</b></p>
<p><b>⚠ Vapors from flammable liquids will explode and catch fire causing death or severe burns.</b> Do not use or store flammable products such as gasoline, solvents or adhesives in the same room or area near the water heater. Keep flammable products: 1. far away from heater, 2. in approved containers, 3. tightly closed and 4. out of children's reach.</p>	<p>Water heater has a main burner and pilot flame. The pilot flame: 1. which can come on at any time and 2. will ignite flammable vapors. Vapors: 1. cannot be seen, 2. are heavier than air, 3. go a long way on the floor and 4. can be carried from other rooms to the pilot flame by air currents.</p>
<p><b>Installation:</b> Do not install water heater where flammable products will be stored or used unless the main burner and pilot flames</p>	<p>are at least 18" above the floor. This will reduce, but not eliminate, the risk of vapors being ignited by the main burner or pilot flame.</p>
<p>Read and follow water heater warnings and instructions. If owners manual is missing, contact the retailer or manufacturer.</p>	
<p>Water temperature over 125°F can cause severe burns instantly or death from scalds. Children, disabled and elderly are at highest risk of being scalded. See instruction manual before setting temperature at water heater. Feel water before bathing or showering. Temperature limiting valves are available, see manual.</p>	

### **E. APPLIANCE WATER**

- Do not use petroleum-based cleaning or sealing compounds in a system serviced by this appliance. Gaskets and seals in the system may be damaged. This can result in substantial property damage.
- Do not use "homemade cures" or "patent medicines". Substantial property damage, damage to appliance, and/or serious personal injury may result.

## **PART 2 – BEFORE YOU START**

### **A. WHAT'S IN THE BOX**

Also included with the appliance:

- Intake PVC Tee with Screens
- Exhaust PVC Coupling with Screens
- Temperature and Pressure Relief Valve
- Installation Manual
- Warranty
- Solar Addendum (Solar Models Only)
- Outdoor Sensor (Part # 7250P-319)
- Mixing Valve (Part # 7100P-315)

### **B. HOW THE APPLIANCE OPERATES**

The **Versa Hydro with Total System Control** is truly revolutionary, providing high efficiency central heating and domestic hot water from one appliance. Total System Control manages system needs, assuring maximum comfort and efficient operation. Some features of the appliance are:

### Stainless Steel Water Storage Tank

The storage tank is constructed of 316L stainless steel to provide maximum corrosion resistance. Water blown foam insulation and a plastic jacket provide superior insulation, allowing no more than ½ degree heat loss per hour.

### High Efficiency Heat Exchanger

The highly efficient 90/10 copper nickel heat exchanger provides direct energy transfer from the combustion gases into domestic water. Hot gases travel from the primary circuit to heat the combustion walls, which then transfer heat directly into the water. The secondary circuit then transfers the last bit of energy to the bottom of the tank, where the hot gases are converted to water vapor, giving the appliance a combustion efficiency of 98% and thermal efficiency of up to 96%.

### Modulating Combustion System

The modulating combustion system is designed to regulate firing rate based on heat demand. Total System Control monitors tank operation, system parameters, and controls the firing rate of the burner, providing only the energy required to satisfy both the domestic hot water and central heating needs.

### Total System Control

Total System Control automatically manages the needs of both the central heating and domestic hot water systems through the use of sensors. These sensors monitor inputs (such as outdoor temperature, tank temperature, and heating module outlet temperature) providing data that allows accurate control of the entire system. You may choose to use the control's factory default settings or reprogram the system parameters to provide design flexibility.

### Hydronic Heating Module

The hydronic heating module connects to the storage tank through two dip tubes. The first dip tube draws heated water from the top of the storage tank and circulates it through a brazed plate heat exchanger that transfers the water's stored energy to the hydronic side of the plate. Once the energy is transferred, the water returns through the second dip tube to a lower section of the storage tank to continue circulating. A stainless steel circulator pump modulates output, varying flow through the brazed plate heat exchanger to meet domestic hot water and central heating demand. An outlet sensor provides feedback to the control to assure accurate temperature control.

### Venting System

This appliance vents in plastic pipe. Use only the approved venting material outlined in the venting section (Part 8) of this manual. Vent size can vary from 2" to 3" depending on the appliance input rate. The venting system requires an exhaust vent and intake pipe. Special attention should be taken when selecting vent location. Vents can run horizontally or vertically, depending on system design. Support the vents as shown in Venting, Part 8.

### Burner

The burner is constructed of high grade stainless steel and uses pre-mixed air and gas to provide a wide range of firing rates.

### Condensate Drain Connection

This is a condensing high efficiency appliance, and therefore has a condensate removal system. Condensate is nothing more than water vapor derived from combustion products. Appliance condensate is similar to that of an automobile when it is initially started.

It is very important that the condensate line slopes away from the appliance, down to a suitable drain. If the condensate outlet is lower than the drain, you must use a condensate removal pump (kit p/n 554200, available from HTP).

A condensate filter, if required by local authorities, will neutralize the condensate, and can be made up of lime crystals, marble or phosphate chips. This filter can be purchased from HTP (p/n 7450P-212) and installed in the field.

It is also very important that the condensate line not be exposed to freezing temperatures or any other type of blockage. Plastic pipe must be the only material used for condensate line. Steel, brass, copper, or other materials will be subject to corrosion or deterioration.

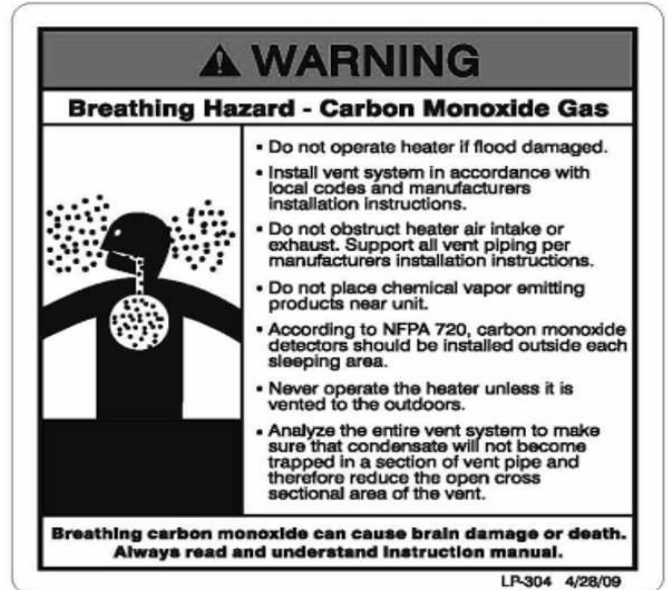
In a long, horizontal condensate line, a second vent may be necessary to prevent vacuum lock. Also, an increase in pipe size and support of the condensation line may be necessary to allow condensate to drain properly.

### Spark Ignition

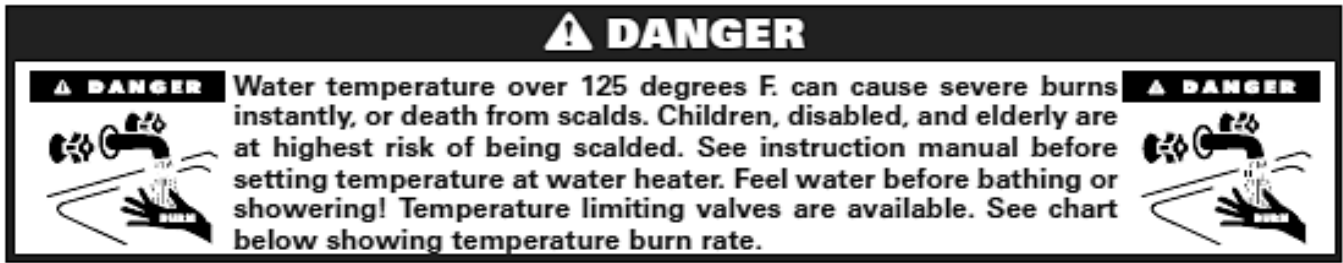
The burner flame is ignited by applying high voltage to the system spark electrode. This causes a spark from electrode to ground.

### Outdoor Sensor

The outdoor sensor monitors outdoor temperature and adjusts the set point to provide greater efficiency.







### **C. OPTIONAL EQUIPMENT**

Below is a list of optional equipment available from HTP:

- 3" Stainless Steel Outside Termination Vent Kit (V1000)
- 4" Stainless Steel Outside Termination Vent Kit (V2000)
- 2" PVC Concentric Vent Kit (Part # KGAVT0501CVT)
- 3" PVC Concentric Vent Kit (Part # KGAVT0601CVT)
- 3" Polypro Vent Kit (Part # 8400P-001)
- 3" Polypro Pipe (33' length Part # 8400P-002, 49.5' length Part # 8400P-003)
- System Sensor (Part # 7250P-324)
- Alarm System (Part # 7350P-602) to monitor any failure
- PC Connection Kit (Part # 7250P-320)
- Condensate Neutralizer (Part # 7450P-212)
- Outdoor Sensor (Part # 7250P-319)
- Versa-Hydro Solar Kit (Part # 7100P-220)

**NOTE:** When using an optional system sensor, pipe insulation must be wrapped around it to improve temperature measurement accuracy and increase overall system efficiency.

## **PART 3 – PREPARE APPLIANCE LOCATION**

### **CAUTION**

Carefully consider installation when determining appliance location. Please read the entire manual before attempting installation. Failure to properly take factors such as appliance venting, piping, condensate removal, and wiring into account before installation could result in wasted time, money, and possible property damage and personal injury.

### **A. BEFORE LOCATING THE APPLIANCE**

### **WARNING**

Incorrect ambient conditions can lead to damage to the heating system and put safe operation at risk. Ensure that the appliance installation location adheres to the information included in this manual. Failure to do so could result in property damage, serious personal injury, or death.

### **CAUTION**

Failure of appliance or components due to incorrect operating conditions IS NOT covered by product warranty.

#### 1. Installation Area (Mechanical Room) Operating Conditions

- Ensure ambient temperatures are higher than 32°F/0°C and lower than 104°F/40°C.
- Prevent the air from becoming contaminated by the products, places, and conditions listed in this manual, Part 3, Section F.
- Avoid continuously high levels of humidity
- Never close existing ventilation openings
- Ensure a minimum 1" clearance around hot water and exhaust vent pipes

### **CAUTION**

The service life of the appliance's exposed metallic surfaces, such as the casing, as well as internal surfaces, such as the heat exchanger, are directly influenced by proximity to damp and salty marine environments. In such areas, higher concentration levels of chlorides from sea spray coupled with relative humidity can lead to degradation of the heat exchanger and other appliance components. In these environments, appliances must not be installed using direct vent systems which draw outdoor air for combustion. Such appliances must be installed using room air for combustion. Indoor air will have a much lower relative humidity and, hence, potential corrosion will be minimized.

## ⚠ WARNING

This appliance is certified for indoor installations only. Do not install the appliance outdoors. Failure to install this appliance indoors could result in substantial property damage, severe personal injury, or death.

2. Check for nearby connections to:

- System water piping
- Venting connections
- Gas supply piping
- Electrical power
- Condensate drain

3. Check area around appliance. Remove any combustible materials, gasoline, and other flammable liquids.

## ⚠ WARNING

Failure to keep appliance area clear and free of combustible materials, liquids, and vapors can result in substantial property damage, severe personal injury, or death.

4. Gas control system components must be protected from dripping water during operation and service.

5. If the appliance is to replace an existing appliance, check for and correct any existing system problems, such as:

- System leaks
- Location that could cause the system and appliance to freeze and leak.
- Incorrectly-sized expansion tank

6. Clean and flush system when reinstalling an appliance.

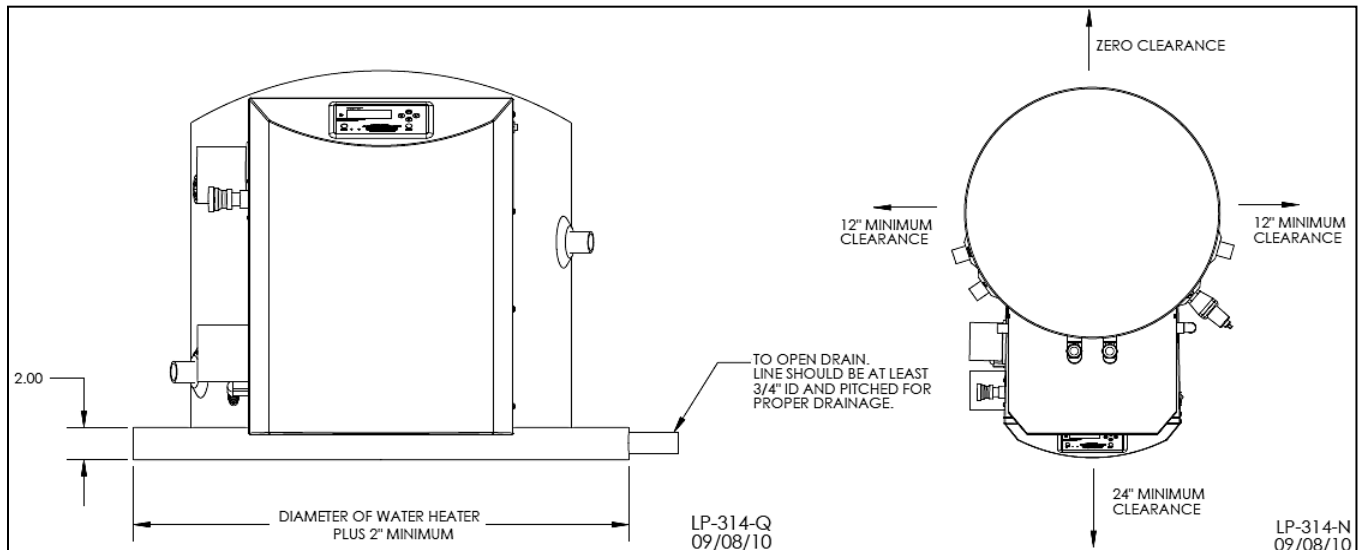
**NOTE:** When installing in a zero clearance location, it may not be possible to read or view some product labeling. It is recommended to make note of the appliance model and serial number.

### B. LEVELING

## ⚠ CAUTION

In order for the condensate to properly flow out of the collection system, the area where you locate the appliance must be level. Location must also fully support the weight of the filled appliance.

### C. CLEARANCES FOR SERVICE ACCESS



**Figure 1 - If you do not provide the minimum clearances shown above, it might not be possible to service the appliance without removing it from the space.**

## CAUTION

A catch pan must be installed to protect the surrounding area from possible leaking water damage.

## **WARNING**

The space must be provided with combustion/ventilation air openings correctly sized for all other appliances located in the same space as the appliance. Failure to comply with the above warnings could result in substantial property damage, severe personal injury, or death.

### **D. RESIDENTIAL GARAGE INSTALLATION**

#### **PRECAUTIONS**

If the appliance is located in a residential garage, per ANSI Z223.1:

- Mount the bottom of the appliance a minimum of 18" above the floor of the garage, to ensure the burner and ignition devices are well off the floor.
- When raising the appliance, be certain to fully support its entire filled weight.
- Locate or protect the appliance so it cannot be damaged by a moving vehicle.

### **E. EXHAUST VENT AND INTAKE PIPE**

The appliance is rated ANSI Z21.10.3 Category IV (pressurized vent, likely to form condensate in the vent) and requires a special vent system designed for pressurized venting.

**NOTE: The venting options described here (and further detailed in the Venting section of this manual) are the lone venting options approved for this appliance. Failure to vent the appliance in accordance with the provided venting instructions will void the warranty.**

## **DANGER**

Failure to vent the appliance properly will result in serious personal injury or death.

## **WARNING**

Vents must be properly supported. Appliance exhaust and intake connections are not designed to carry heavy weight. Vent support brackets must be within 1' of the appliance and the balance at 4' intervals. Appliance must be readily accessible for visual inspection for the first 3' from the appliance.

### **1. DIRECT VENT INSTALLATION OF EXHAUST VENT AND INTAKE PIPE**

If installing a direct vent option, combustion air must be drawn from the outdoors directly into the appliance intake, and exhaust must terminate outside. There are three basic direct vent options detailed in this manual: 1. Side Wall Venting, 2. Roof Venting, and 3. Unbalanced Venting.

Be sure to locate the appliance such that the exhaust vent and intake piping can be routed through the building and properly terminated. Different vent terminals can be used to simplify and eliminate multiple penetrations in the building structure (see Optional Equipment in Venting Section). The exhaust vent and intake piping lengths, routing and termination methods must all comply with the methods and limits given in the Venting section of this manual.

When installing a combustion air intake from outdoors, care must be taken to utilize uncontaminated combustion air. **NOTE: To prevent combustion air contamination, see Table 1.**

### **2. INDOOR COMBUSTION AIR INSTALLATION IN CONFINED OR UNCONFINED SPACE**

This appliance requires fresh, uncontaminated air for safe operation and must be installed in a mechanical room where there is adequate combustion and ventilating air. **NOTE: To prevent combustion air contamination, see Table 1.**

Combustion air from the indoor space can be used if the space has adequate area or when air is provided through a duct or louver to supply sufficient combustion air based on the appliance input. **Never obstruct the supply of combustion air to the appliance.** If the appliance is installed in areas where indoor air is contaminated (see Table 1) it is imperative that the appliance be installed as direct vent so that all combustion air is taken directly from the outdoors into the appliance intake connection.

**Unconfined space** is space with volume greater than 50 cubic feet per 1,000 Btu/hour (4.8 cubic meters per kW) of the total input rating of all fuel-burning appliances installed in that space. Rooms connected directly to this space, through openings not furnished with doors, are considered part of the space. See **Figure 21**, p. 40 for details.

**Confined space** is space with volume less than 50 cubic feet per 1,000 Btu/hour (4.8 cubic meters per kW) of the total input rating of all fuel-burning appliances installed in that space. Rooms connected directly to this space, through openings not furnished with doors, are considered part of the space.

When drawing combustion air from inside a conventionally constructed building to a confined space, such space should be provided with two permanent openings: one located 6" (15 cm) below the space ceiling, the other 6" (15cm) above the space floor. Each opening

should have a free area of one square inch per 1,000 Btu/hr (22cm<sup>2</sup>/kW) of the total input of all appliances in the space, but not less than 100 square inches (645cm<sup>2</sup>).

If the confined space is within a building of tight construction, air for combustion must be obtained from the outdoors as outlined in the Venting section of this manual.

**CAUTION**

When drawing combustion air from the outside into the mechanical room, care must be taken to provide adequate freeze protection.

**⚠ WARNING**

Do not attempt to vent this appliance by any means other than those described in this manual. Doing so will void the warranty, and may result in severe personal injury or death.

**⚠ WARNING**

Failure to provide an adequate supply of fresh combustion air can cause poisonous flue gases to enter living space, which could result in severe personal injury or death.

**F. PREVENT COMBUSTION AIR CONTAMINATION**

Install intake piping for the appliance as described in the Venting section. Do not terminate exhaust in locations that can allow contamination of intake air.

**⚠ WARNING**

**You must pipe outside air to the appliance air intake.** Ensure that the intake air will not contain any of the contaminants below. Contaminated air will damage the appliance, resulting in possible substantial property damage, severe personal injury, or death. For example, do not pipe intake near a swimming pool. Also, avoid areas subject to exhaust fumes from laundry facilities. These areas always contain contaminants.

PRODUCTS TO AVOID	AREAS LIKELY TO HAVE CONTAMINANTS
Spray cans containing fluorocarbons	Dry cleaning/laundry areas and establishments
Permanent wave solutions	Swimming pools
Chlorinated waxes/cleaners	Metal fabrication plants
Chlorine-based swimming pool chemicals	Beauty shops
Calcium chloride used for thawing	Refrigeration repair shops
Sodium chloride used for water softening	Photo processing plants
Refrigerant leaks	Auto body shops
Paint or varnish removers	Plastic manufacturing plants
Hydrochloric or Muriatic acid	Furniture refinishing areas and establishments
Cements and glues	New building construction
Antistatic fabric softeners used in clothes dryers	Remodeling areas
Chlorine-type bleaches, laundry detergents, and cleaning solvents	Garages and workshops
Adhesives used to fasten building products	

**Table 1 – Contaminant Table**

**NOTE: DAMAGE TO THE APPLIANCE CAUSED BY EXPOSURE TO CORROSIVE VAPORS IS NOT COVERED BY WARRANTY.**  
(Refer to the limited warranty for complete terms and conditions).

**G. REMOVING AN APPLIANCE FROM A COMMON VENT SYSTEM**

**⚠ DANGER**

Do not install the appliance into a common vent with any other appliance. This will cause flue gas spillage or appliance malfunction, resulting in possible substantial property damage, severe personal injury, or death.

**⚠ WARNING**  
 Failure to follow all instructions can result in flue gas spillage and carbon monoxide emissions, causing severe personal injury or death.

When removing an existing appliance, follow the steps below.

1. Seal any unused openings in the common venting system.
2. Visually inspect the venting system for proper size and horizontal pitch to determine if there is blockage, leakage, corrosion or other deficiencies that could cause an unsafe condition.
3. If practical, close all building doors, windows and doors between the space in which the appliance remains connected to the common venting system and other spaces in the building. Turn on clothes dryers and any appliances not connected to the common venting system. Turn on any exhaust fans, such as range hoods and bathroom exhausts, at maximum speed. Do not operate a summer exhaust fan. Close all fireplace dampers.
4. Place in operation the appliance being inspected. Follow the lighting instructions. Adjust the thermostat so the appliance will operate continuously.
5. Test for spillage at the draft hood relief opening after 5 minutes of main burner operation. Use the flame of a match or candle or smoke from a cigarette.
6. After it has been determined that each appliance remaining connected to common venting system properly vents when tested as outlined, return doors, windows, exhaust fans, fireplace dampers and any other gas burning appliance to their previous condition of use.
7. Any improper operation of the common venting system should be corrected to conform to the National Fuel Gas Code, ANSI Z223.1. When resizing any portion of the common venting system, the system should approach the minimum size as determined using the appropriate tables in Appendix G in the National Fuel Gas Code, ANSI Z 223.1.

**H. WATER CHEMISTRY**

**CAUTION**  
 Chemical imbalance of the water supply may affect efficiency and cause severe damage to the appliance and associated equipment. HTP recommends having water quality professionally analyzed to determine whether it is necessary to install a water softener. It is important that the water chemistry on both the domestic hot water and central heating sides are checked before installing the appliance, as water quality will affect the reliability of the system. Failure of a heat exchanger due to lime scale build-up on the heating surface, low pH, or other chemical imbalance IS NOT covered by the warranty.

Outlined below are water quality parameters which need to be met in order for the system to operate efficiently for many years.


**Water Hardness**

Water hardness is mainly due to the presence of calcium and magnesium salts dissolved in water. The concentration of these salts is expressed in mg/L, ppm, or grains per gallon as a measure of relative water hardness. Grains per gallon is the common reference measurement used in the U.S. water heater industry. Hardness expressed as mg/L or ppm may be divided by 17.1 to convert to grains per gallon. Water may be classified as very soft, slightly hard, moderately hard, or hard based on its hardness number. The minerals in the water precipitate out as the water is heated and cause accelerated lime scale accumulation on a heat transfer surface. This lime scale build-up may result in premature failure of the heat exchanger. Operating temperatures above 135°F will further accelerate the build-up of lime scale on the heating surface and may shorten the service life of the appliance.

Water that is classified as hard and very hard must be softened to avoid heat exchanger failure. See below for further information about water hardness.

CLASSIFICATION	MG/L OR PPM	GRAINS/GAL
Soft	0 – 17.1	0 - 1
Slightly Hard	17.1 – 60	1 – 3.5
Moderately Hard	60 – 120	3.5 – 7.0
Hard	120 – 180	7.0 – 10.5
Very Hard	180 and over	10.5 and over

**⚠ WARNING**  
**Breathing Hazard - Carbon Monoxide Gas**



- Do not operate heater if flood damaged.
- Install vent system in accordance with local codes and manufacturers installation instructions.
- Do not obstruct heater air intake or exhaust. Support all vent piping per manufacturers installation instructions.
- Do not place chemical vapor emitting products near unit.
- According to NFPA 720, carbon monoxide detectors should be installed outside each sleeping area.
- Never operate the heater unless it is vented to the outdoors.
- Analyze the entire vent system to make sure that condensate will not become trapped in a section of vent pipe and therefore reduce the open cross sectional area of the vent.

**Breathing carbon monoxide can cause brain damage or death. Always read and understand instruction manual.**

LP-304 4/28/09

Figure 2

If the hardness of the water exceeds the maximum level of 7 grains per gallon, water should be softened to a hardness level no lower than 5 grains per gallon. Water softened as low as 0 to 1 grain per gallon may be under-saturated with respect to calcium carbonate, resulting in water that is aggressive and corrosive.

#### **pH of Water**

pH is a measure of relative acidity, neutrality or alkalinity. Dissolved minerals and gases affect water pH. The pH scale ranges from 0 to 14. Water with a pH of 7.0 is considered neutral. Water with a pH lower than 7 is considered acidic. Water pH higher than 7 is considered alkaline. A neutral pH (around 7) is desirable for most potable water applications. **Corrosion damage and appliance failures resulting from water pH levels of lower than 6 or higher than 8 ARE NOT covered by the warranty.** The ideal pH range for water used in a storage tank or a water heater system is 7.2 to 7.8.

#### **Total Dissolved Solids**

Total Dissolved Solids (TDS) is a measurement of all minerals and solids dissolved in a water sample. The concentration of total dissolved solids is usually expressed in parts per million (ppm).

Water with a high TDS concentration will greatly accelerate lime and scale formation in the hot water system. Most high TDS concentrations precipitate out of the water when heated. This can generate a scale accumulation on the heat transfer surface that will greatly reduce the service life of an appliance. This scale accumulation can also impede the ability of the heat exchanger to transfer heat into the water. A heat exchanger damaged or blocked by lime/scale accumulation must be replaced.

The manufacturer of the appliance has no control of water quality, especially TDS levels in your system. Total dissolved solids in excess of 2,000 ppm will accelerate lime and scale formation in the heat exchanger. Heat exchanger failure due to total dissolved solids in excess of 2,000 ppm is a non-warrantable condition. **Failure of an appliance due to lime scale build up on the heating surface IS NOT covered by the warranty.**

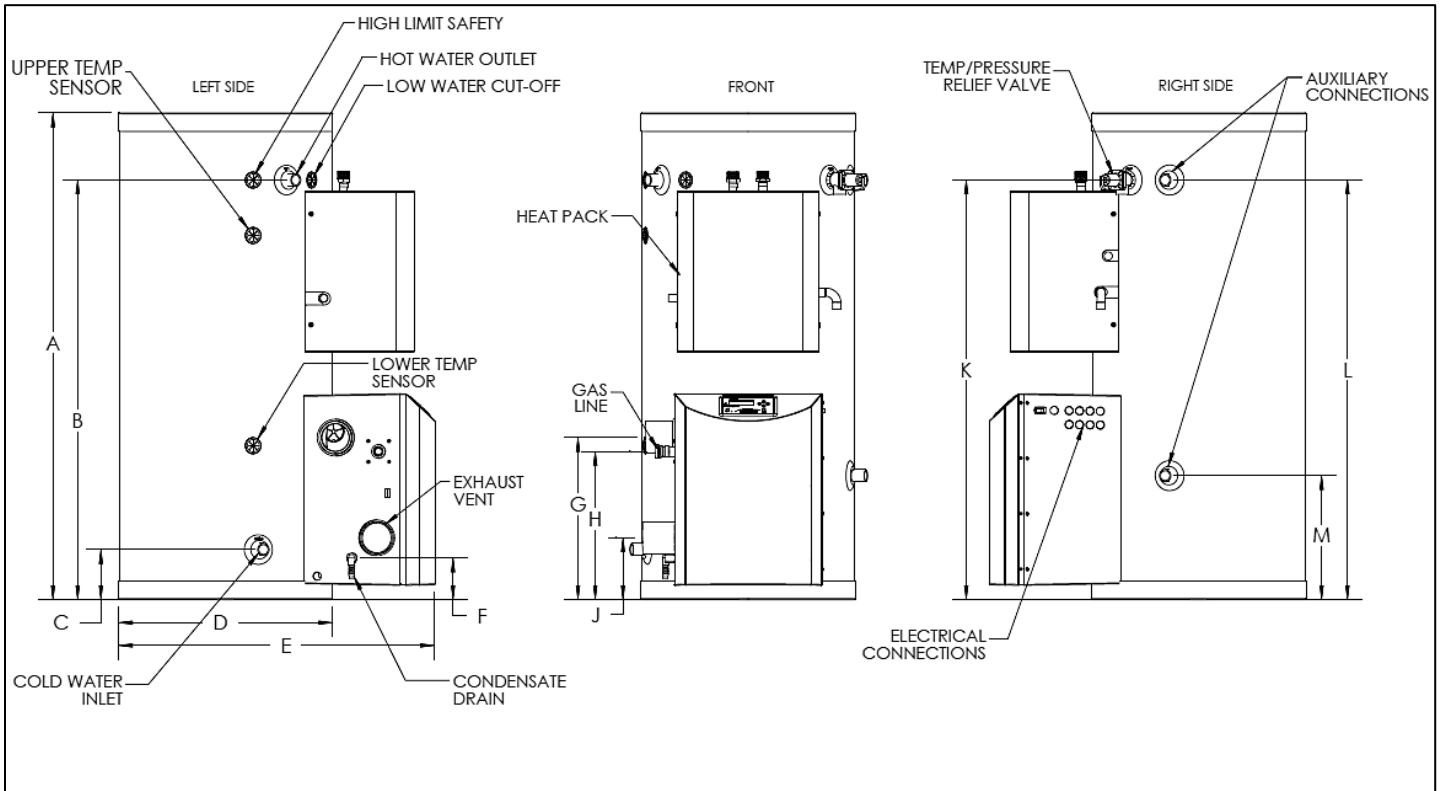
**Hardness:** 7 grains

**Chloride levels:** 100 ppm

**pH levels:** 6-8

**TDS:** 2000 ppm

**Sodium:** 20 mGL



VERSA-HYDRO WATER HEATER DIMENSIONS													
MODEL #*	GALLONS	A	B	C	D	E	F	G	H	J	K	L	M
PHE130-55 / PHE199-55	55	53"	45"	5"	23"	34"	4"	17-1/2"	16"	6-1/2"	45"	45"	13"
PHE130-80 / PHE199-80	80	72"	64-1/2"	5-1/2"	23"	34"	6-1/4"	19-1/2"	18"	8-1/2"	64-1/2"	64-1/2"	13"
PHE130-119 / PHE199-119	119	74"	66"	7-1/4"	27"	37"	7-1/2"	20-1/2"	19"	9-1/2"	66"	66"	14-1/2"

ALL DIMENSIONS ARE APPROXIMATE

VERSA-HYDRO WATER HEATER SPECIFICATIONS								
MODEL #*	GALLONS	INPUT MODULATION	AIR INTAKE/ EXHAUST VENT SIZE	WATER INLET/ OUTLET SIZE	AUXILIARY CONN.	GAS LINE CONN.	SYSTEM RELIEF PIPE SIZE	SHIPPING WEIGHT
PHE130-55 / PHE199-55	55	35,000 - 130,000	2"	1" NPT	1" FNPT	3/4"	3/4"	205 LBS.
		40,000 - 199,000	3"					
PHE130-80 / PHE199-80	80	35,000 - 130,000	2"	1" NPT	1" FNPT	3/4"	3/4"	265 LBS.
		40,000 - 199,000	3"					
PHE130-119 / PHE199-119	119	35,000 - 130,000	2"	1" NPT	1" FNPT	3/4"	3/4"	435 LBS.
		40,000 - 199,000	3"					

\* A Suffix of "N" denotes natural gas and "LP" denotes propane gas

LP-314- X  
08/15/12

Figure 3 – Specifications and Dimensions

**⚠ WARNING**

**UNCRATING HEATER** – Any claims for damage or shortage in shipment must be filed immediately against the transportation company by the consignee.

**⚠ CAUTION**

**COLD WEATHER HANDLING** – If the heater has been stored in a very cold location (BELOW 0°F) before installation, handle with care until the plastic components come to room temperature.

Remove all sides of the shipping crate to allow the heater to be lifted into its installation location.

## PART 4 - DOMESTIC WATER PIPING

### WARNING

Failure to follow the instructions in this section WILL VOID the warranty and may result in property damage, serious injury, or death.

### CAUTION

DO NOT pipe this appliance with black iron, galvanized steel, steel, or lead pipe. Doing so will result in premature product failure and property damage, and WILL VOID the product warranty.

#### **A. TEMPERATURE AND PRESSURE RELIEF VALVE FOR DHW**

Install a temperature and pressure relief valve into the marked port (upper right). We recommend a WATTS 40XL5 valve or equivalent for 130,000 BTU models or above input. The valve must meet the ANSI Z21.22B requirements for relief valves for hot water heaters as per a nationally recognized lab that maintains a periodic inspection of production of such listed safety device. The pressure rating of the valve must not exceed the listed working pressure of this appliance, and must be rated to the proper BTU/hr capacity of the appliance.

### WARNING

To avoid water damage or scalding due to relief valve operation:

- Discharge line must be connected to relief valve outlet and run to a safe place of disposal. Terminate the discharge line in a manner that will prevent possibility of severe burns or property damage should the relief valve discharge.
- Discharge line must be as short as possible and the same size as the valve discharge connection throughout its entire length.
- Discharge line must pitch downward from the valve and terminate at least 6" above the floor drain, making discharge clearly visible.
- The discharge line shall terminate plain, not threaded, with a material serviceable for temperatures of 375°F or greater.
- Do not pipe discharge to any location where freezing could occur.
- No shutoff valve may be installed between the relief valve and heater or in the discharge line. Do not plug or place any obstruction in the discharge line.
- Test the operation of the relief valve after filling and pressurizing the system by lifting the lever. Make sure the valve discharges freely. If the valve fails to operate correctly, immediately replace with a new properly rated relief valve.
- Test T&P valve at least once annually to ensure the waterway is clear. If valve does not operate, turn the heater "off" **and call a plumber immediately.**
- Take care whenever operating relief valve to avoid scalding injury or property damage.

**FAILURE TO COMPLY WITH THE ABOVE GUIDELINES COULD RESULT IN FAILURE OF RELIEF VALVE OPERATION, RESULTING IN POSSIBILITY OF SUBSTANTIAL PROPERTY DAMAGE, SEVERE PERSONAL INJURY, OR DEATH.**

### WARNING

Do not, under any circumstances, thread a cap or plug into the relief valve! Explosion, serious injury or death may result. Relief valve piping must be directed to the floor or an open drain, but not connected.

### DANGER

#### DANGER



Water temperature over 125 degrees F. can cause severe burns instantly, or death from scalds. Children, disabled, and elderly are at highest risk of being scalded. See instruction manual before setting temperature at water heater. Feel water before bathing or showering! Temperature limiting valves are available. See chart below showing temperature burn rate.

#### DANGER



There must be a 6" space between the outlet of relief valve piping and drain or floor. Do not hook up to drain system directly without an air space. The relief valve must be checked periodically for proper operation.

#### **B. DOMESTIC HOT WATER EXPANSION TANK**

A potable hot water expansion tank is required to offset the expansion as the water is heated. In most city plumbing systems, the water meter has a no return or back flow device built into the system to prevent water flowing back into city mains. Some local codes require back flow preventers on all incoming water supplies. The hot water expansion tank must be listed for potable water use. The expansion tank should be located on the cold inlet piping close to the appliance.

### CAUTION

The expansion tank must be suitable for hot potable water.



**CAUTION**

Never use dielectric unions or galvanized steel fittings on any domestic water or auxiliary connections. Use only copper or brass fittings. Thread sealant must be used on all connections.

**C. DOMESTIC WATER PIPING**

Domestic water connections must be installed in accordance with all local and national plumbing codes or any applicable prevailing standards. The appliance is supplied with a rated mixing valve certified to ASSE 1017. You must completely follow the instructions included with the mixing valve for proper installation. This mixing valve must be installed on the domestic outlet to assure that hot water temperature does not vary more than +/- 5°F, as the unit adjusts its stored water automatic set point to meet the requirements of the hydronic heating module. The valve **MUST NOT** be allowed to freeze. If the mixing valve is installed in a potentially freezing situation, suitable insulation must be fitted to prevent damage. **DO NOT** use excess thread sealant (in liquid, tape or other form) as this may cause the mixing valve to fail. Toxic chemicals shall not be introduced into the mixing valve system.

**Recommend to the user that the mixing valve be checked annually to ensure its continued function.**

**D. APPLIANCE PIPING**

The domestic inlet and outlet ports on the appliance are 1" NPT connections. We recommend the installation of shut-off valves and unions on both the inlet and outlet ports to isolate the appliance for future service.

It is important that the connections on the inlet and outlet are brass or copper. Never use dielectric unions or galvanized steel fittings. Teflon thread sealant must be used to seal all tank connections. An approved ASSE 1017 mixing valve is provided with every appliance and must be installed on the outlet to protect the user from scalding temperatures. This valve reduces the point of discharge temperature by mixing the hot and cold water from the discharge outlet or mixed outlet port. This device alone will not protect the user from scalding temperature. To install and set up the mixing valve, follow the pre-installation steps in this manual and also follow the enclosed instructions included with the mixing valve.

**E. MIXING VALVE INSTALLATION**

**⚠ WARNING**

The mixing valve provided with this appliance must be installed on the hot water outlet connection to reduce the risk of scalding. This mixing valve only reduces the risk of scalding injury.



1. All installations must be carried out by licensed professionals.
2. The installer must ensure compatibility of all installations. Example: Temperature of hot water – marked “H”, cold water inlet – marked “C”, and mixed outlet – marked with directional arrow.
3. The mixing valve may be installed in any position.
4. Local codes shall take priority over any inconsistency in these instructions.
5. During startup, you must ensure that the valve is set to the desired temperature (the mixing valve preset is 120°F). If the valve temperature needs to be adjusted, please refer to the mixing valve instructions and/or the following settings.

APPROXIMATE TIME / TEMPERATURE RELATIONSHIPS IN SCALDS	
120°F	More than 5 minutes
125°F	1 ½ to 2 minutes
130°F	About 30 seconds
135°F	About 10 seconds
140°F	Less than 5 seconds
145°F	Less than 3 seconds
150°F	About 1 ½ seconds
155°F	About 1 second

Table 2

**⚠ DANGER**

**⚠ DANGER** Water temperature over 125 degrees F. can cause severe burns instantly, or death from scalds. Children, disabled, and elderly are at highest risk of being scalded. **⚠ DANGER**

**⚠ DANGER**

Hotter water increases the risk of scald injury. Scalding may occur within 5 seconds at a setting of 140°F (60°C). Water temperature over 125°F can instantly cause severe burns, or death, from scalds. Children, disabled, and elderly are at the highest risk of being scalded. See instruction manual before setting temperature at appliance. Feel water before bathing or showering!

## **WARNING**

This appliance can deliver scalding temperature water at any faucet in the system. Be careful whenever using hot water to avoid scalding injury. By setting the thermostat on this appliance to obtain increased water temperature, you may create a higher potential for scald injury. To protect against injury, you should install an ASSE approved thermostatic mixing valve (a device to limit the temperature of water to protect against scald injury by mixing hot and cold water supply) in the system. This valve will reduce point of discharge temperature in branch supply lines. This appliance was shipped with an ASSE approved thermostatic mixing valve. Install this valve according to the directions in the mixing device container. **DO NOT OPERATE THIS APPLIANCE WITHOUT AN ASSE APPROVED THERMOSTATIC MIXING DEVICE.** If this appliance was shipped without an ASSE approved thermostatic mixing valve, contact the manufacturer.

## **CAUTION**

The mixing valve is certified to ASSE 1017. It is not to be used to provide anti-scald service resulting from system pressure fluctuations, and should not be used where more sophisticated compensating temperature controls are required.

### Mixing Valve Specification

Min. – Max. Hot Water Inlet Temperature	120 - 180°F (49 - 82°C)
Min. – Max. Cold Water Inlet Temperature	39 - 80°F (4 - 27°C)
Max. Working Pressure	200 PSI
Min. Flow Rate	1 GPM
Outlet Water Temperature Range	85 – 130°F (29 – 54°C)
Min. Temperature Differential (Between Hot Supply and Outlet)	27°F (15°C)
Factory Set Locking Ring	120°F Max. <sup>1</sup>
Allowable Supply Pressure Variation	+/- 20% <sup>2</sup>
Accuracy of Outlet Temperature	+/- 3°F (3.4°C)
Performance –	
CV	1.8
Max Flow – 1"	14 gpm

### Notes:

<sup>1</sup>Maximum permissible temperature in accordance with ASSE 1070. The limit locking ring may be adjusted for applications not requiring ASSE 1070 valves.

<sup>2</sup>Maximum allowable variation in either supply pressure in order to control the outlet temperature to within +/- 3°F. **Warning: Pressure variations outside of this range may cause changes in the outlet temperature.**

**NOTE:** At low flow operation, the outlet temperature may vary slightly more.

Differential pressure at the valve inlet should be within a 2 to 1 ratio under normal flow conditions.

Inline fittings, pipe work, layout and sizing must be taken into consideration. In installations where the valve is supplied with unbalanced hot cold pressures greater than a 2 to 1 ratio, please call HTP Technical Support Department.

### Installation of the Mixing Valve

1. Flush all pipe work thoroughly (with water only) before installing the mixing valve.
2. The mixing valve comes complete with union type connections for ease of installation and service.
3. The mixing valve must be removed from the pipe work prior to soldering the end connections. It is recommended to use a spacer piece while soldering.

## **DANGER**

Do not solder unions while attached to the valve body. Solder connections prior to connecting unions to the valve body to avoid damaging the valve and its function.

### Setting the Mixing Valve Outlet Temperature

1. Turn both the hot and cold water supplies on. Open an outlet, preferably a sink or basin faucet rather than a shower. To calibrate, let water run for 2 minutes and measure the outlet temperature with a thermometer. Adjust the green cap counter clockwise to increase temperature and clockwise to decrease temperature, as shown in Fig. 4.

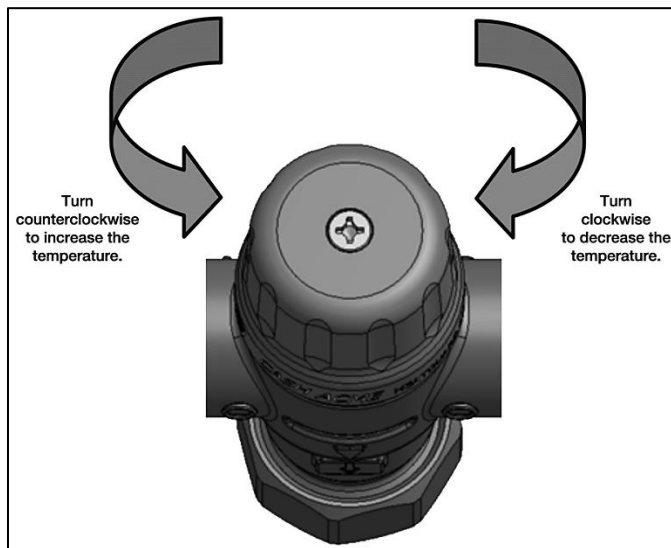


Figure 4 – Adjusting the Mixing Valve

2. Once the desired outlet temperature has been achieved, refit the green top so that it snaps onto the body of the mixing valve.

**NOTE:** See the instruction sheet included with the mixing valve to adjust the maximum temperature of the mixing valve greater than 120°F.

## **⚠ DANGER**

Hotter water increases the risk of scald injury. Scalding may occur within 5 seconds at a setting of 140°F (60°C). Water temperature over 125°F can instantly cause severe burns, or death, from scalds. Children, disabled, and elderly are at the highest risk of being scalded. See instruction manual before setting temperature at appliance. Feel water before bathing or showering!

### **MIXING VALVE MAINTENANCE AND SERVICE**

- It is recommended to check the mixing valve annually to ensure proper system capabilities. More frequent checks are recommended in adverse water conditions.
- When checking the mixed water supply temperature, use the same faucet used in the initial installation temperature adjustment.
- There may be some variation in the water temperature from the mixing valve due to seasonal temperature variations in the cold water supply.

**If the water supply is of poor quality, the internal components may jam, requiring an additional filter or strainer to be fitted to the system. Contact a plumbing professional for appropriate materials and installation.**

### **F. AUXILIARY PIPING**

Auxiliary connections are provided to connect to an air handler, plate exchanger or other additional devices. Auxiliary ports can also be used for recirculation line connections. These connections must be installed in accordance with all local and national codes or any applicable prevailing standards. Auxiliary connections are 1" on all models. Never use dielectric unions or galvanized steel fittings. Use only copper or brass fittings. Teflon sealant must be used on all connections. The top port has a dip tube that draws hot water from the dome of the unit and the bottom port dip tube returns the water to bottom of the unit.

## **⚠ WARNING**

Never connect auxiliary connections to any system that uses glycol or other solutions formulated for hydronic systems. These auxiliary connections are to be used only in a potable water system. Failure to follow this warning could result in death or serious injury.

## PART 5 - HYDRONIC PIPING

### **⚠ WARNING**

Failure to follow the instructions in this section WILL VOID the warranty and may result in property damage, serious injury, or death.

#### **A. HYDRONIC HEATING MODULE PIPING**

The hydronic heating module comes pre-plumbed and connected directly to the storage tank. The heated water inside the tank will be circulated through one side of the brazed plate heat exchanger while the heating system water flows through the other side. The heating system piping is connected to the return and supply pipes located on the top of the hydronic heating module (see Figure 5). Piping of the module to the system is not complex and does not require any of the primary or secondary piping normally used on high efficiency low mass boilers.

**NOTE:** Do not connect hydronic heating module to air handler units. This module may not be applied to air handler applications.

#### **B. PRESSURE RELIEF VALVE FOR THE HYDRONIC SYSTEM**

The pressure relief valve supplied with the appliance is designed to relieve pressure greater than 30 psi. The hydronic heating module is designed to withstand pressure up to 150 psi. If you are changing the pressure relief valve for a higher pressure rating, you must make sure that the system components are designed for the higher pressure. The relief valve must be rated for the 135,000 Btu maximum capacity of the brazed plate heat exchanger. Pipe the discharge line in copper piping to a drain. Provide 6" clearance from the floor drain.

#### **C. HYDRONIC EXPANSION TANK AND MAKE UP WATER**

Ensure that the expansion tank is sized to the system volume, brazed plate capacity, and related piping for the hydronic heating module. The capacity of the module and brazed plate is ½ gallon. Most chilled water systems are piped using a closed type expansion tank.

Connect the expansion tank to the air separator only if the separator is on the suction side of the circulator. The hydronic heating module has a water line connection of ½" NPT to connect into the pressure reducing valve and back flow preventer. Normal system pressure is 15 psi.

#### **D. HYDRONIC HEATING MODULE SYSTEM PIPING**

The hydronic heating module is designed to function in a closed loop hydronic system. The included temperature and pressure gauge allows the user to monitor the system pressure and temperature from the hydronic heating module. The gauge should be installed on the supply outlet piping from the heating module. The installation of an air elimination device will remove air from the system which is necessary to avoid an air lock in the central heating circulator. It is recommended that all the piping is insulated to improve on the system's overall efficiency. In the system piping, heating coils in air handler, flow control valves, or other devices must be installed to prevent gravity circulation of heated water from the heating module.

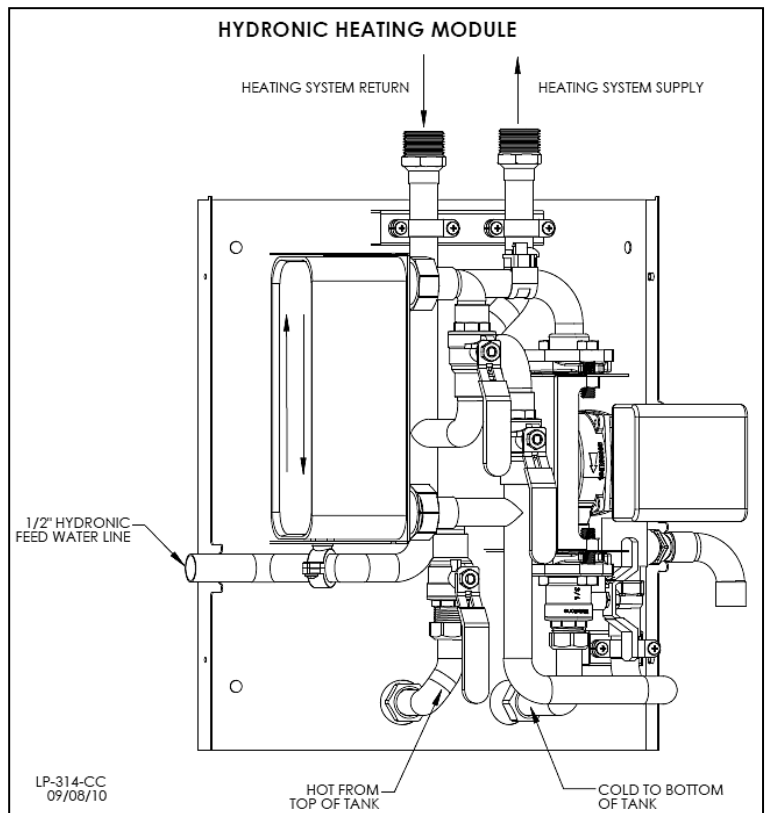


Figure 5 – Hydronic Heating Module

Freeze protection for new or existing systems must be composed of glycol that is specifically formulated to include inhibitors that will prevent the glycol from attacking the metallic system components. Make certain that the system fluid is checked for the correct glycol concentration and inhibitor level. The system should be tested at least once a year or as recommended by the producer of the glycol solution. Allowance should be made for the expansion of the glycol solution in the system piping. Example: 50% by volume glycol solution expands 4.8% in volume for the temperature increase from 32°F to 180°F, while water expands 3% with the same temperature rise.

Listed below are the basic steps that will help guide you through the installation of the hydronic heating module to the system piping.

1. Connect the system return marked "Return".
2. Connect the system supply marked "Supply".

3. Install a balance and purge valve (or shut off drain valve) on the system return to purge air out of the zone at start-up.
4. Install a back flow preventer on the cold feed make-up water line.
5. Install a pressure reducing valve on the cold feed make up water line (15 psi operating pressure). Check temperature and pressure gauge when operating. It should read minimum pressure of 15 psi.
6. Install the system circulator as shown in the piping details in this section. Make sure the circulator is properly sized for the system and friction loss.
7. Install an expansion tank on the system supply. Consult the expansion tank manufacturer's instructions for specific information related to expansion for the required system volume and capacity.
8. Install an air elimination device on the system supply.
9. Install a drain valve at the lowest point of system to blow out the system if needed. NOTE: The hydronic heating module cannot be drained completely of water without purging the unit with an air pressure greater than 15 psi but not exceeding 40 psi. If winterizing the unit it is recommended, use glycol on the closed loop hydronic side only.
10. The relief valve is installed at the factory. A pipe discharge line should be installed to release 6" above a drain, so discharge will be visible when pressure is relieved. The pipe size must be the same size as the relief valve outlet.

### **WARNING**

Never block the outlet of the safety relief valve.

#### **E. HYDRONIC HEATING MODULE OUTPUT**

Hydronic heating module output is based on the burner input and the flow rate supplied by the selected system circulator through the closed loop side of the brazed plate exchanger. Included in this section are graphs that will help you size the appropriate circulator and output needed to meet your system design requirements. Below is an example on the steps needed to determine the correct circulator for the system.

#### **Example: System design requires 120,000 Btu at 20 Delta**

##### **Step 1**

Using the graphs, select the input rate of the appliance. In this example, we would have to select a minimum input of 199K (the 130K max. output is 100,000 Btu, which falls below our operating point).

##### **Step 2**

Next, go to the chart for the 199K burner input and select the point of operation where the Btu and Delta T line intersect. Mark the point on the chart and go to bottom of the chart to determine flow rate needed to achieve the rated output from the module. This example is 12 GPM.

##### **Step 3**

Select the correct circulator to meet the flow and resistance requirements for the system design. To calculate this, you must determine the flow and resistance through the system and heating module. The heating module requires 12 GPM at 10 feet of head. The system requires 12 GPM at 5 feet of head. To select a circulator, add the resistance 10 feet of head (module) + 5 feet of head (system) at 12 GPM. This system requires a circulator that operates at a resistance of 15 feet at 12 GPM (See examples in Figure 6, Figure 7, and Figure 8).

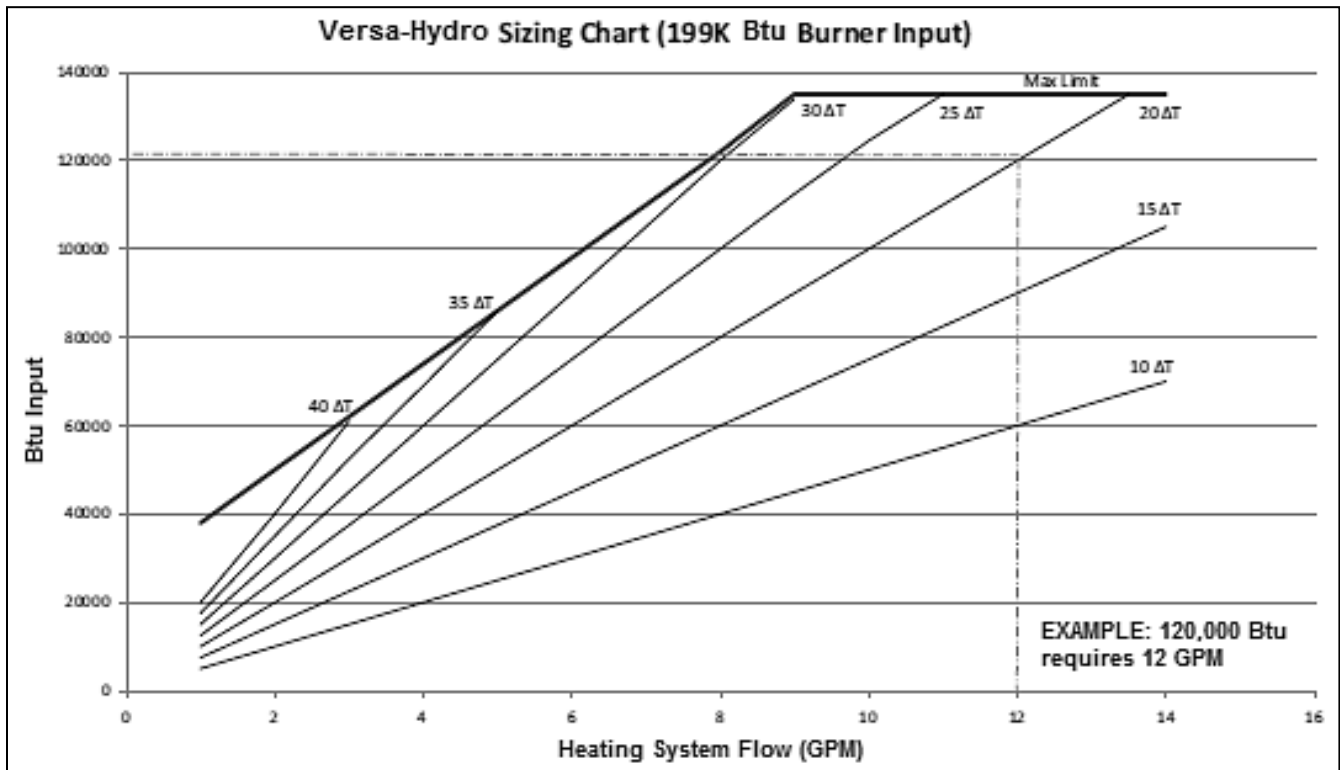


Figure 6

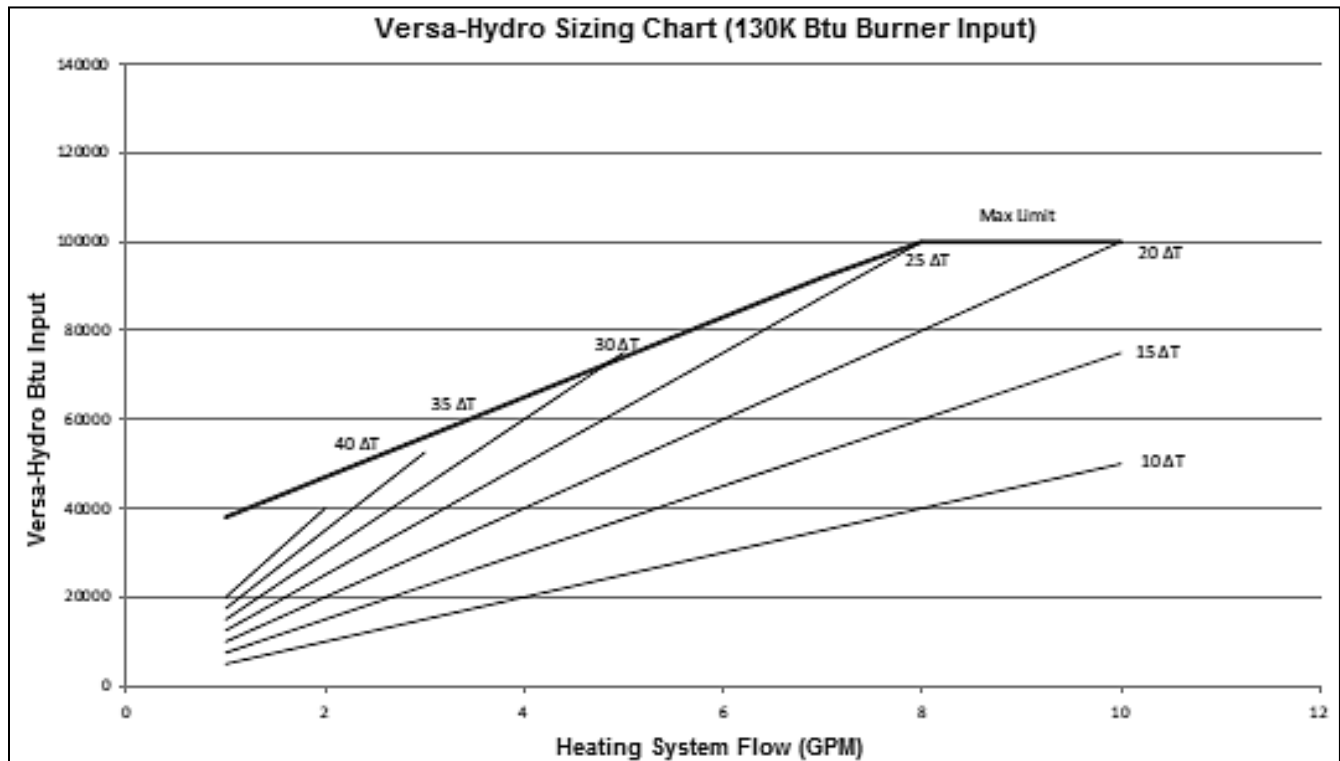


Figure 7

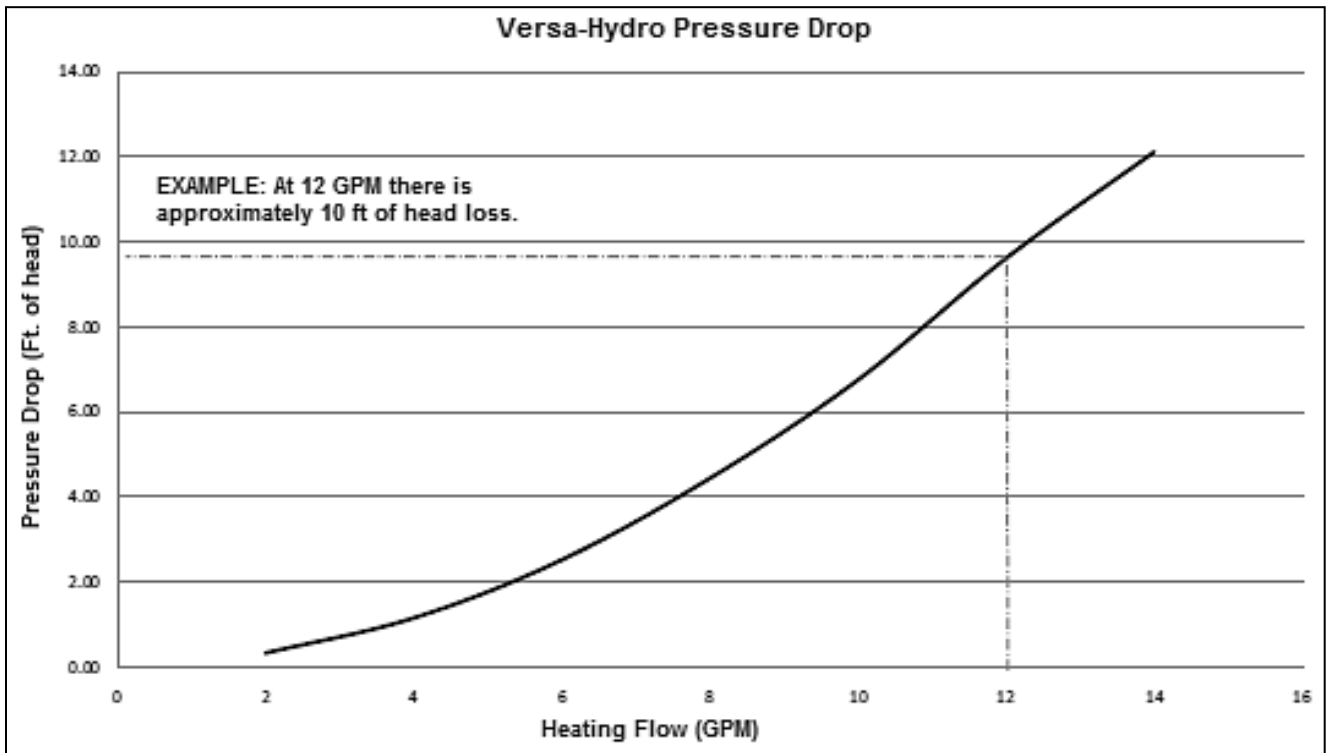


Figure 8

## F. HYDRONIC PIPING

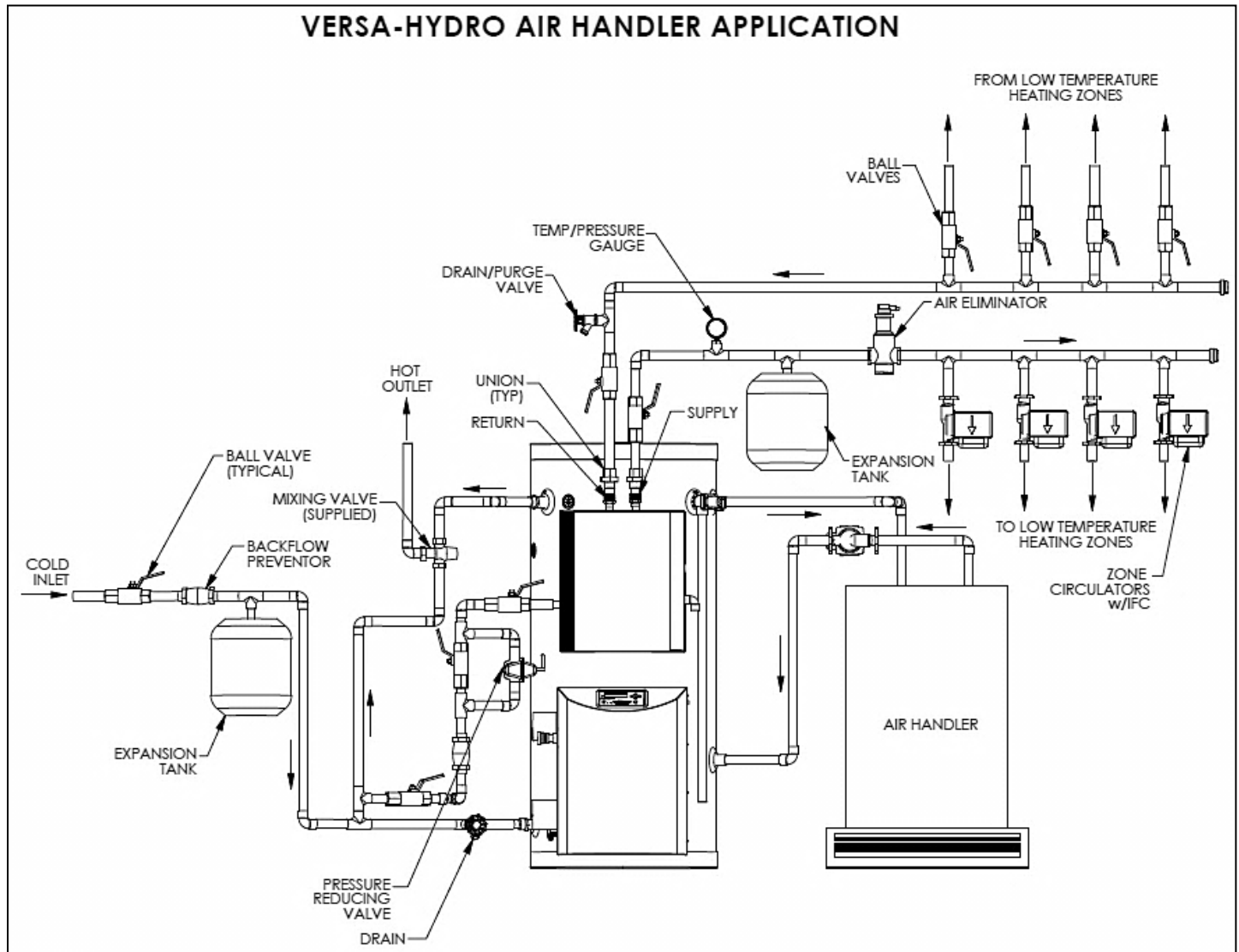


Figure 9 – LP-314-3

### NOTES:

1. Minimum pipe size should match connection size on appliance. Upsize pipe accordingly if greater flow is required.
2. A thermal expansion tank suitable for potable water must be sized and installed within the piping system between the check valve and cold water inlet of the appliance.
3. Gas line must be rated to the maximum capacity of the unit. Unit must have 10 feet of pipe after gas regulator.
4. All circulators shall have an integral flow check.

### NOTES FOR AIR HANDLER APPLICATION (APPLIES TO DOMESTIC WATER OUTLET CONNECTIONS ONLY):

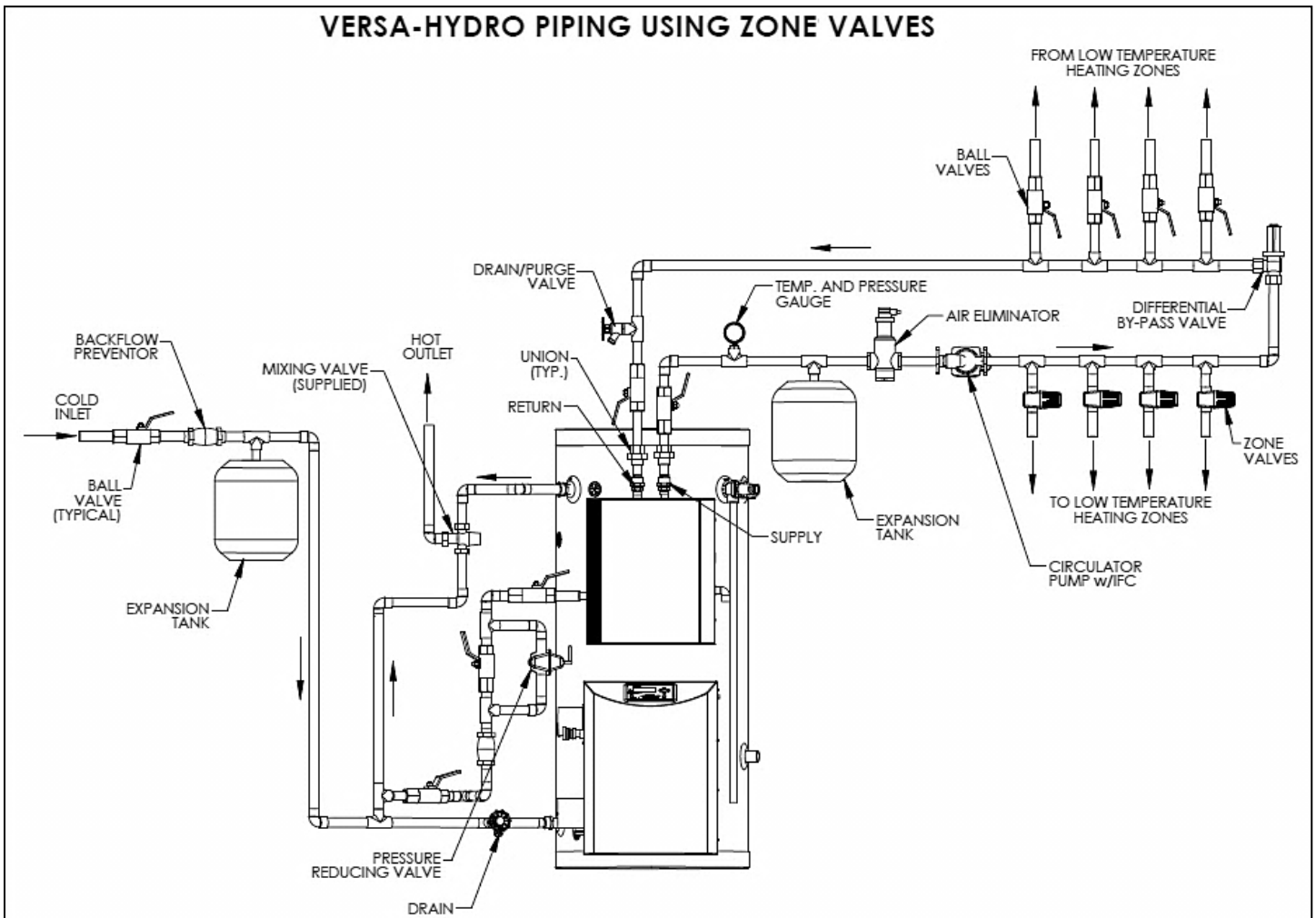
1. MASSACHUSETTS STATE PLUMBING CODE REQUIRES A DISTANCE NO GREATER THAN 50 FEET FROM THE APPLIANCE TO THE FAN COIL IN THE AIR HANDLER.
2. MASSACHUSETTS STATE PLUMBING CODE REQUIRES AN ELECTRONICALLY TIMED CIRCULATOR PUMP TO ACTIVATE EVERY SIX HOURS FOR 60 SECONDS. THIS CIRCULATOR IS REQUIRED TO BE BRONZE OR STAINLESS.
3. ALL WATER PIPING MUST BE INSULATED.
4. YOU MUST INSTALL A VACUUM RELIEF VALVE PER 248 CMR.

**NOTE: THIS DRAWING IS MEANT TO DEMONSTRATE SYSTEM PIPING ONLY. THE INSTALLER IS RESPONSIBLE FOR ALL EQUIPMENT AND DETAILING REQUIRED BY LOCAL CODES.**

## CAUTION

DO NOT use the heat pack for high temperature (over 160°F) applications. Failure to comply will result in substantial overworking of the appliance, and possibly lead to early appliance failure. Use of the heat pack for high temperature applications WILL VOID the warranty.





**Figure 10 – LP-314-PIPING-1**

**NOTES:**

1. Minimum pipe size should match connection size on appliance. Upsize pipe accordingly if greater flow is required.
2. A thermal expansion tank suitable for potable water must be sized and installed within the piping system between the check valve and cold water inlet of the appliance.
3. Gas line must be rated to the maximum capacity of the unit. Unit must have 10 feet of pipe after gas regulator.
4. All circulators shall have an integral flow check.

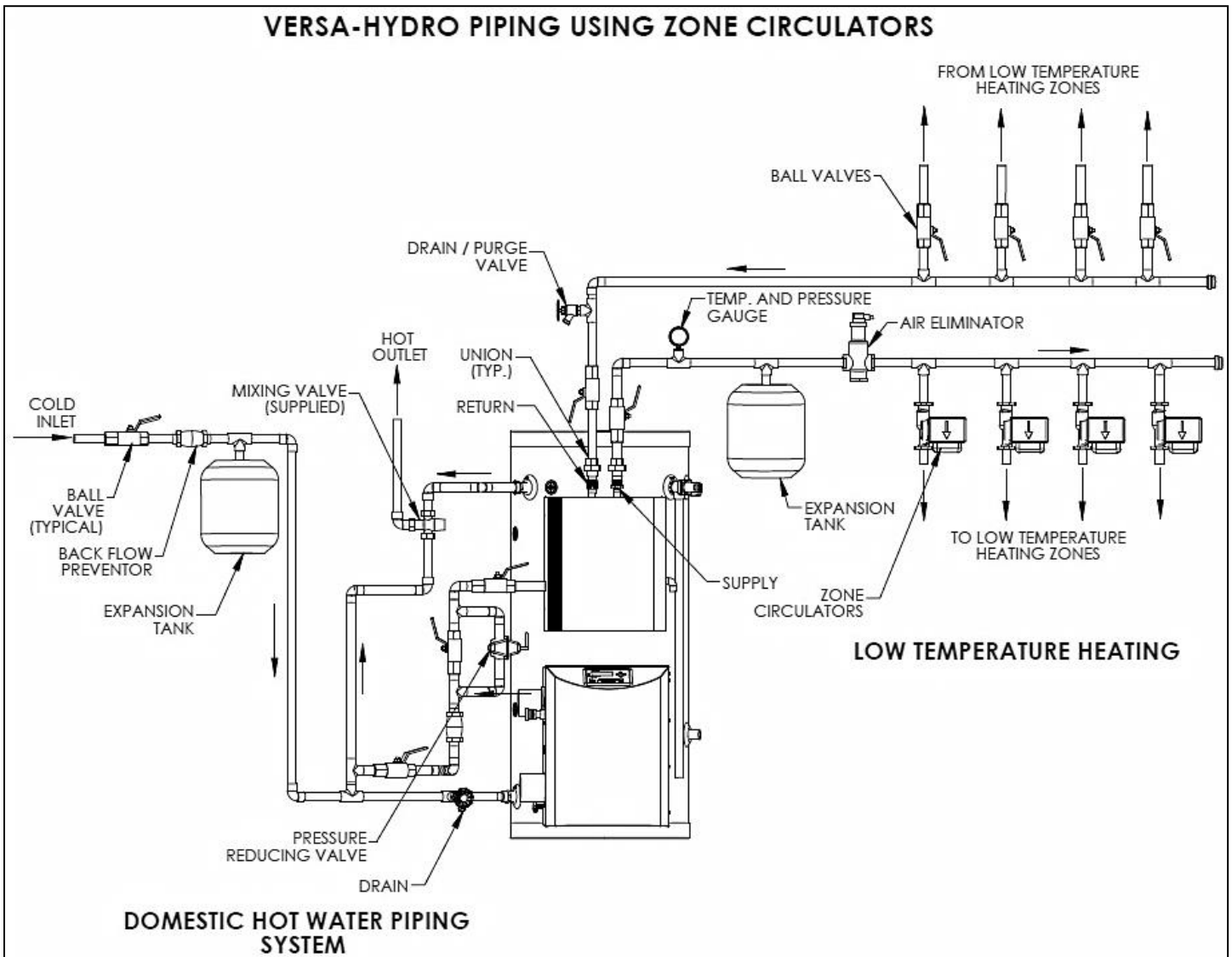
**NOTES FOR AIR HANDLER APPLICATION (APPLIES TO DOMESTIC WATER OUTLET CONNECTIONS ONLY):**

1. MASSACHUSETTS STATE PLUMBING CODE REQUIRES A DISTANCE NO GREATER THAN 50 FEET FROM THE APPLIANCE TO THE FAN COIL IN THE AIR HANDLER.
2. MASSACHUSETTS STATE PLUMBING CODE REQUIRES AN ELECTRONICALLY TIMED CIRCULATOR PUMP TO ACTIVATE EVERY SIX HOURS FOR 60 SECONDS. THIS CIRCULATOR IS REQUIRED TO BE BRONZE OR STAINLESS.
3. ALL WATER PIPING MUST BE INSULATED.
4. YOU MUST INSTALL A VACUUM RELIEF VALVE PER 248 CMR.

**NOTE: THIS DRAWING IS MEANT TO DEMONSTRATE SYSTEM PIPING ONLY. THE INSTALLER IS RESPONSIBLE FOR ALL EQUIPMENT AND DETAILING REQUIRED BY LOCAL CODES.**

**CAUTION**

DO NOT use the heat pack for high temperature (over 160°F) applications. Failure to comply will result in substantial overworking of the appliance, and possibly lead to early appliance failure. Use of the heat pack for high temperature applications WILL VOID the warranty.



**Figure 11 – LP-314-PIPING-2**

**NOTES:**

1. Minimum pipe size should match connection size on appliance. Upsize pipe accordingly if greater flow is required.
2. A thermal expansion tank suitable for potable water must be sized and installed within the piping system between the check valve and cold water inlet of the appliance.
3. Gas line must be rated to the maximum capacity of the unit. Unit must have 10 feet of pipe after gas regulator.
4. All circulators shall have an integral flow check.

**NOTES FOR AIR HANDLER APPLICATION (APPLIES TO DOMESTIC WATER OUTLET CONNECTIONS ONLY):**

1. MASSACHUSETTS STATE PLUMBING CODE REQUIRES A DISTANCE NO GREATER THAN 50 FEET FROM THE APPLIANCE TO THE FAN COIL IN THE AIR HANDLER.
2. MASSACHUSETTS STATE PLUMBING CODE REQUIRES AN ELECTRONICALLY TIMED CIRCULATOR PUMP TO ACTIVATE EVERY SIX HOURS FOR 60 SECONDS. THIS CIRCULATOR IS REQUIRED TO BE BRONZE OR STAINLESS.
3. ALL WATER PIPING MUST BE INSULATED.
4. YOU MUST INSTALL A VACUUM RELIEF VALVE PER 248 CMR.

**NOTE: THIS DRAWING IS MEANT TO DEMONSTRATE SYSTEM PIPING ONLY. THE INSTALLER IS RESPONSIBLE FOR ALL EQUIPMENT AND DETAILING REQUIRED BY LOCAL CODES.**

**CAUTION**

DO NOT use the heat pack for high temperature (over 160°F) applications. Failure to comply will result in substantial overworking of the appliance, and possibly lead to early appliance failure. Use of the heat pack for high temperature applications WILL VOID the warranty.

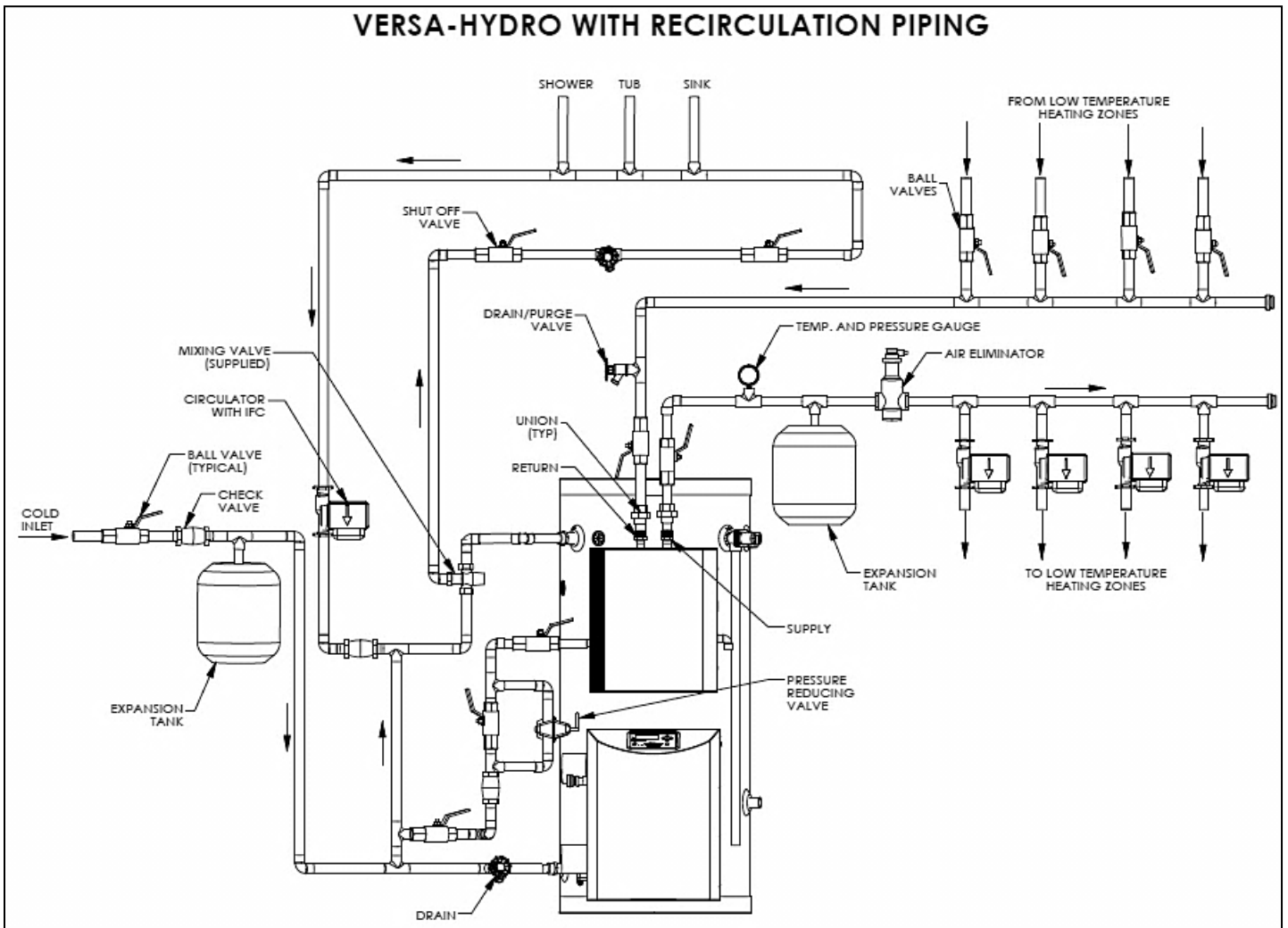


Figure 12 – LP-314-PIPING-4

**NOTES:**

1. Minimum pipe size should match connection size on appliance. Upsize pipe accordingly if greater flow is required.
2. A thermal expansion tank suitable for potable water must be sized and installed within the piping system between the check valve and cold water inlet of the appliance.
3. Gas line must be rated to the maximum capacity of the unit. Unit must have 10 feet of pipe after gas regulator.
4. All circulators shall have an integral flow check.

**NOTES FOR AIR HANDLER APPLICATION (APPLIES TO DOMESTIC WATER OUTLET CONNECTIONS ONLY):**

1. MASSACHUSETTS STATE PLUMBING CODE REQUIRES A DISTANCE NO GREATER THAN 50 FEET FROM THE APPLIANCE TO THE FAN COIL IN THE AIR HANDLER.
2. MASSACHUSETTS STATE PLUMBING CODE REQUIRES AN ELECTRONICALLY TIMED CIRCULATOR PUMP TO ACTIVATE EVERY SIX HOURS FOR 60 SECONDS. THIS CIRCULATOR IS REQUIRED TO BE BRONZE OR STAINLESS.
3. ALL WATER PIPING MUST BE INSULATED.
4. YOU MUST INSTALL A VACUUM RELIEF VALVE PER 248 CMR.

**NOTE: THIS DRAWING IS MEANT TO DEMONSTRATE SYSTEM PIPING ONLY. THE INSTALLER IS RESPONSIBLE FOR ALL EQUIPMENT AND DETAILING REQUIRED BY LOCAL CODES.**

**CAUTION**

DO NOT use the heat pack for high temperature (over 160°F) applications. Failure to comply will result in substantial overworking of the appliance, and possibly lead to early appliance failure. Use of the heat pack for high temperature applications WILL VOID the warranty.

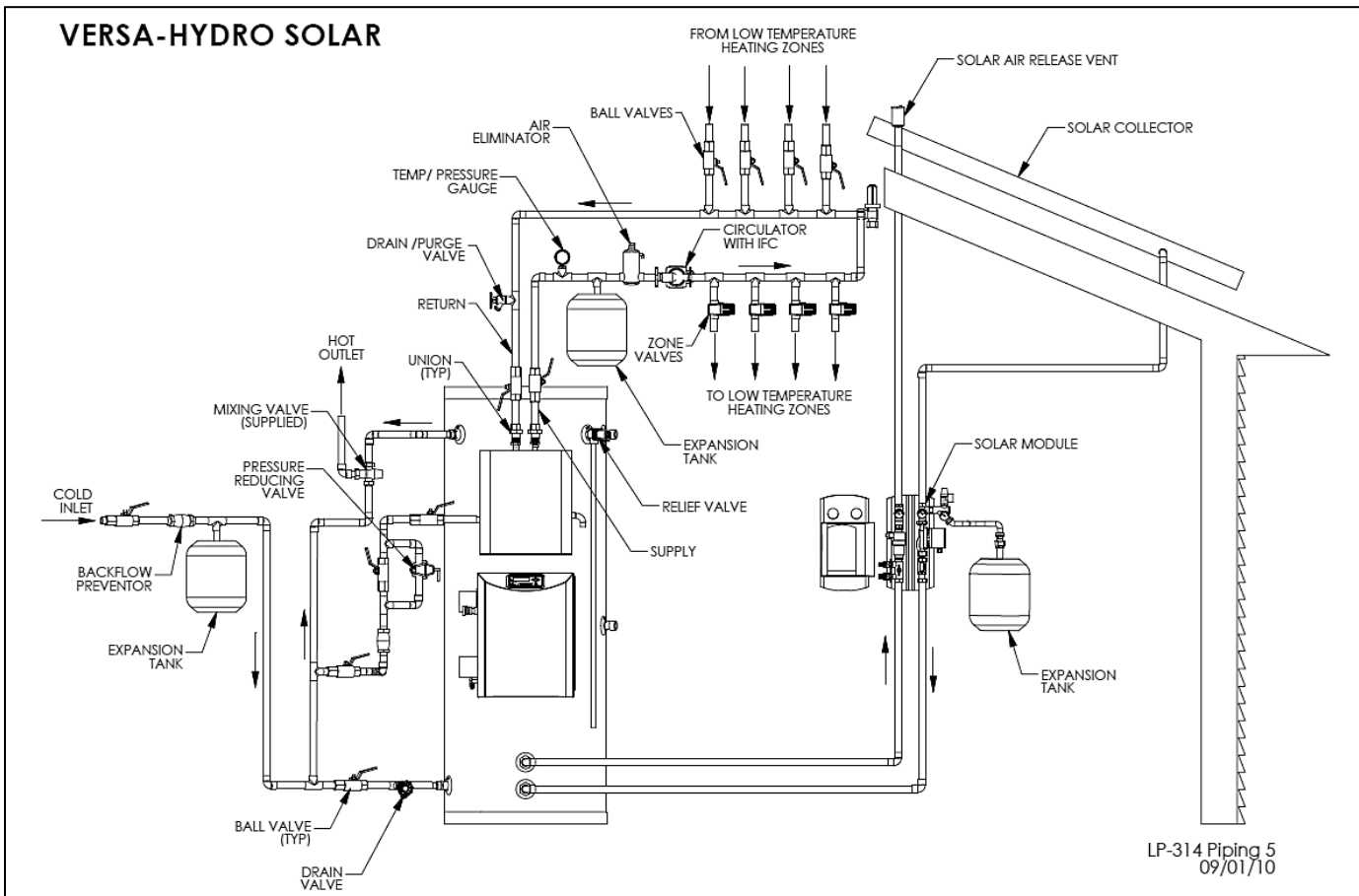


Figure 13 – LP-314-PIPING-5

**NOTES:**

1. Minimum pipe size should match connection size on appliance. Upsize pipe accordingly if greater flow is required.
2. A thermal expansion tank suitable for potable water must be sized and installed within the piping system between the check valve and cold water inlet of the appliance.
3. Gas line must be rated to the maximum capacity of the unit. Unit must have 10 feet of pipe after gas regulator.
4. All circulators shall have an integral flow check.

**NOTES FOR AIR HANDLER APPLICATION (APPLIES TO DOMESTIC WATER OUTLET CONNECTIONS ONLY):**

1. MASSACHUSETTS STATE PLUMBING CODE REQUIRES A DISTANCE NO GREATER THAN 50 FEET FROM THE APPLIANCE TO THE FAN COIL IN THE AIR HANDLER.
2. MASSACHUSETTS STATE PLUMBING CODE REQUIRES AN ELECTRONICALLY TIMED CIRCULATOR PUMP TO ACTIVATE EVERY SIX HOURS FOR 60 SECONDS. THIS CIRCULATOR IS REQUIRED TO BE BRONZE OR STAINLESS.
3. ALL WATER PIPING MUST BE INSULATED.
4. YOU MUST INSTALL A VACUUM RELIEF VALVE PER 248 CMR.

**NOTE: THIS DRAWING IS MEANT TO DEMONSTRATE SYSTEM PIPING ONLY. THE INSTALLER IS RESPONSIBLE FOR ALL EQUIPMENT AND DETAILING REQUIRED BY LOCAL CODES.**

**CAUTION**

DO NOT use the heat pack for high temperature (over 160°F) applications. Failure to comply will result in substantial overworking of the appliance, and possibly lead to early appliance failure. Use of the heat pack for high temperature applications WILL VOID the warranty.

## PART 6 - VENTING, COMBUSTION AIR AND CONDENSATE REMOVAL

### DANGER

The appliance must be vented as detailed in this Venting Section. Ensure exhaust and intake piping complies with these instructions regarding vent system. Inspect finished exhaust vent and intake piping thoroughly to ensure all joints are well secured, airtight, and comply with all applicable code requirements, as well as with the instructions provided in this manual. Failure to properly install the vent system will result in severe personal injury or death.

#### A. GENERAL

### DANGER

This appliance is certified as a “Category IV” appliance, and requires a special venting system. The vent system will operate with a positive pressure in the pipe. Exhaust gases must be piped directly outdoors using the vent materials and rules outlined in these instructions. Do not connect vent connectors serving appliances vented by natural draft into any portion of mechanical draft systems operating under positive pressure. Follow the venting instructions below carefully. Failure to do so will result in substantial property damage, severe personal injury, or death.

### DANGER

Exhaust vent and intake pipes are to be piped separately. This appliance cannot share a common exhaust or intake with multiple appliances. Failure to follow this instruction will result in substantial property damage, severe personal injury, or death.

1. Installation should be made in accordance with the regulations of the Authority Having Jurisdiction, local code authorities, and utility companies which pertain to this type of water heating equipment.
2. Install the venting system in accordance with these instructions and with the National Fuel Gas Code, ANSI Z223.1/NFPA 54, CAN/CGA B149, and/or applicable provisions of local building codes.
3. This appliance must be vented with materials, components, and systems listed and approved for Category IV appliances.

**NOTE:** To avoid contamination often contained in indoor air, it is best to pipe all intake combustion air directly to the outdoors.

**NOTE:** If exhaust vent pipe system passes through an unheated space, such as an alcove or attic, the space must be heated or the pipe must be insulated. The insulation must have an R value sufficient to prevent freezing of the condensate.

### WARNING

Improper seating of vent pipe gaskets can cause eventual gasket failure and exhaust gas leakage. Ensure the exhaust vent pipe is properly beveled and seated before insertion into the flue adapter. Failure to do so could result in property damage, severe personal injury, or death.

### DANGER

Due to the extreme flammability of most glues, cements, solvents, and primers used to join plastic exhaust vent and intake pipes, explosive solvent vapors must be cleared from all vent piping before start-up. Avoid using excess cement or primer, as this may pool in the vent pipes. Vent assemblies should be allowed to cure for a period of at least 8 hours before powering a connected appliance. Failure to follow these instructions will result in substantial property damage, severe personal injury, or death. It is the installers' responsibility to understand the hazards associated with explosive solvents and take the necessary precautions to avoid these risks.

**NOTE:** The use of double-wall vent or insulated material for the combustion air inlet pipe is recommended in cold climates to prevent the condensation of airborne moisture in the incoming combustion air.

**B. APPROVED MATERIALS FOR EXHAUST VENT AND INTAKE PIPE**

APPROVED EXHAUST VENT AND INTAKE PIPE MATERIAL			
Item	Material	Standards for Installation in:	
		United States	Canada
Exhaust vent or Intake pipe and fittings	PVC schedule 40/80	ANSI/ASTM D1785	PP, CPVC, and PVC venting must be ULC-S636 Certified. IPEX is an approved manufacturer in Canada, supplying vent material listed to ULC-S636.
	PVC-DWV*	ANSI/ASTM D2665	
	CPVC schedule 40/80	ANSI/ASTM F441	
	Polypropylene	UL-1738	
	Stainless Steel AL29-4C	Certified for Category IV and direct vent appliance venting	Certified for Category IV and direct vent appliance venting
Pipe cement/primer	PVC	ANSI/ASTM D2564	IPEX System 636 Cements & Primers
	CPVC	ANSI/ASTM F493	

** DANGER**

- The exhaust and intake components installed with this appliance must be used for near appliance piping BEFORE transitioning to the approved materials listed above. DO NOT REMOVE these installed components. Doing so WILL VOID appliance warranty.
  - PVC/CPVC pipe and fittings of the same diameter are considered interchangeable.
  - DO NOT use Foam Core Pipe in any portion of the exhaust piping from this water heating appliance.
  - DO NOT connect PVC/CPVC to PP without an approved vent connector.
  - When installing AL29-4C vent piping, install a PVC-to-stainless adapter at the appliance vent connection, and at the termination when using an HTP PVC termination kit. DO NOT mix AL-29-4C piping from different manufacturers unless using adapters specifically designed for the purpose by the manufacturer.
  - \*PVC-DWV for air intake applications ONLY.
- Failure to follow these directions will result in substantial property damage, severe personal injury, or death.

**Table 3 – Approved Materials for Exhaust Vent and Intake Pipe**** WARNING**

DO NOT mix components from different venting systems. The vent system could fail, causing leakage of flue products into the living space. Use only the approved pipe and fitting materials, and primer and cement specifically designed for the material used, as listed in Table 3. Failure to do so could result in property damage, severe personal injury, or death.

** WARNING**

Exhaust vent adaptors are not designed as load-bearing devices, and must not be used to support exhaust vent piping. All vent pipes must be glued, properly supported, and the exhaust vent must be pitched a minimum of ¼" per foot back to the appliance to allow drainage of condensate. Failure to properly support vent piping and follow the information in this statement could result in product damage, severe personal injury, or death.

**CAUTION**

High heat sources (sources generating heat 100°F / 37°C or greater, such as stove pipes, space heaters, etc.) may damage plastic components of the appliance as well as plastic vent pipe materials. Such damages ARE NOT covered by warranty. It is recommended to keep a minimum clearance of 8" from high heat sources. Observe heat source manufacturer instructions, as well as local, state, provincial, and national codes, laws, regulations and ordinances when installing this appliance and related components near high heat sources.

**C. REQUIREMENTS FOR INSTALLATION IN CANADA**

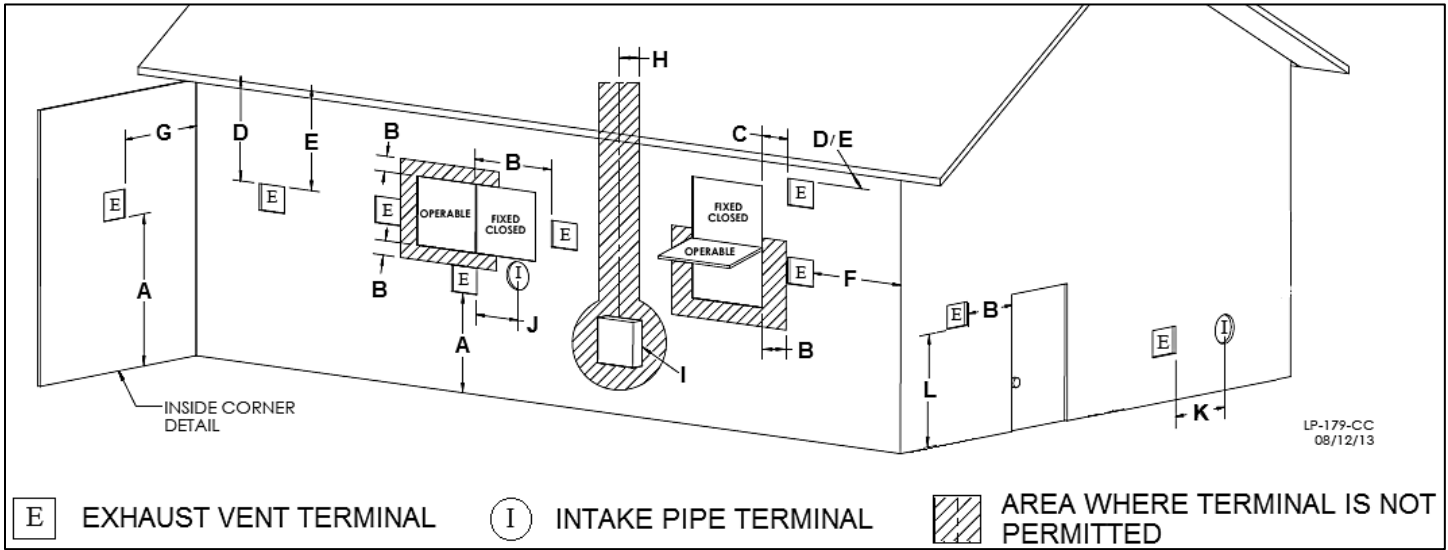
1. Installations must be made with a vent pipe system certified to ULC-S636. IPEX is an approved vent manufacturer in Canada supplying vent material listed to ULC-S636. Additionally you may use AL29-4C stainless steel venting to comply with Canadian requirements.
2. The first three (3) feet of vent pipe from the appliance flue outlet must be readily accessible for visual inspection.
3. The components of the certified vent system must not be interchanged with other vent systems or unlisted pipe / fittings.

Cellular foam core piping may be used on air inlet piping **only**.

** DANGER**

You must not use "B" vent in an exhaust application. "B" vent is for intake applications **ONLY**. Using "B" vent in an exhaust application will result in serious injury or death.

**D. EXHAUST VENT AND INTAKE PIPE LOCATION**




**Figure 14 – ANSI Z223.1 / NFPA 54 for US and CAN/CSA B149.1 for Canada – Exit Terminals for Direct-Vent Venting Systems**

**DETERMINE EXHAUST VENT AND INTAKE PIPE LOCATION – FIGURE 14 NOTES:**

- A.** Provide a minimum of 1 foot clearance from the bottom of the exhaust vent and intake pipe above the expected snow accumulation level. Snow removal may be necessary to maintain clearance.
- B.** Provide a minimum of 1 foot distance from exhaust vent termination to any door, operable window, or gravity intake into any building.
- C.** Provide a minimum of 1 foot distance from exhaust vent termination to any permanently closed door or window.
- D.** Provide a minimum of 4 feet vertical clearance from the exhaust vent to all roof overhangs.
- E.** Locating exhaust vent termination near roof overhangs will result in the formation of icicles in freezing weather, and could result in blockage of the exhaust vent. To prevent icicles from forming, maintain 4 feet vertical clearance from the exhaust vent to all roof overhangs.
- F.** Provide 4 feet clearance from the outside corner of vertical walls, chimneys, etc., as well as horizontal corners created by roof overhangs.
- G.** Provide 6 feet clearance from the inside corner of vertical walls, chimneys, etc., as well as horizontal corners created by roof overhangs.
- H.** Provide 4 feet clearance from center line within a height of 15 feet above electrical meters, gas meters, gas regulators, relief equipment, exhaust fans and inlets.
- I.** Provide 4 feet horizontal clearance from electrical meters, gas meters, gas regulators, relief equipment, exhaust fans and inlets. In no case shall the exit terminal be above or below the aforementioned equipment unless the 4 foot horizontal distance is maintained.
- J.** This vent system shall terminate at least 3 feet (0.9 m) above any forced air intake located within 10 ft (3 m).
- NOTE:** This does not apply to the combustion air intake of a direct-vent appliance.
- K.** When venting with a two pipe system, maximum distance between exhaust vent and intake pipe is 6 feet (1.8 m). Minimum distance between exhaust vent and intake pipe on single direct vented appliance is 10" (0.255 m) center-to-center. Minimum distance between exhaust vents and intake pipes on multiple appliances is 10" (0.255 m) center-to-center.
- L.** When adjacent to a public walkway, locate exit terminal at least 7 feet above grade.

**WARNING**

**Breathing Hazard - Carbon Monoxide Gas**



- Do not operate heater if flood damaged.
- Install vent system in accordance with local codes and manufacturers installation instructions.
- Do not obstruct heater air intake or exhaust. Support all vent piping per manufacturers installation instructions.
- Do not place chemical vapor emitting products near unit.
- According to NFPA 720, carbon monoxide detectors should be installed outside each sleeping area.
- Never operate the heater unless it is vented to the outdoors.
- Analyze the entire vent system to make sure that condensate will not become trapped in a section of vent pipe and therefore reduce the open cross sectional area of the vent.

**Breathing carbon monoxide can cause brain damage or death. Always read and understand instruction manual.**

LP-304 4/28/09

In addition:

- Total length of vent piping shall not exceed the limits specified in this manual.
- The vent piping for this direct vented appliance is approved for zero clearance to combustible construction.
- The flue products coming from the exhaust vent will create a large plume when the appliance is in operation. Avoid venting in areas that will affect neighboring buildings or be considered objectionable.
- DO NOT locate exhaust vent or intake pipe in a parking area where machinery may damage the pipe.
- DO NOT locate the exhaust vent or intake pipe terminals under a porch, balcony, or veranda.
- Avoid terminating exhaust vents near shrubs, air conditioners, or other objects that will obstruct the exhaust stream.
- DO NOT vent over a public walkway. Condensate could drip or freeze and create a nuisance or hazard.
- **NOTE:** Due to potential moisture build-up, sidewall venting may not be the preferred venting option. Carefully consider venting installation and location to save time and cost.

## ⚠ WARNING

The building owner is responsible for keeping the exhaust and intake terminations free of snow, ice, or other potential blockages, as well as scheduling routine maintenance. Failure to keep the vent piping terminations clear and properly maintain the appliance could result in property damage, severe personal injury, or death.

## ⚠ WARNING

For each floor containing bedroom(s), a carbon monoxide detector and alarm shall be placed in the living area outside the bedrooms, as well as in the room that houses the appliance. Detectors and alarms shall comply with NFPA 720 (latest edition). Failure to comply with requirements for detectors and alarms could result in property damage, severe personal injury, or death.

### **E. EXHAUST VENT AND INTAKE PIPE SIZING**

1. The exhaust vent and intake pipe size is 2" for the PHE130 and 3" for the PHE199.
2. The maximum total equivalent length of 2" exhaust vent and intake pipe **must not exceed 85 feet**. The maximum equivalent length of 3" exhaust vent and intake pipe **must not exceed 200 feet**.
  - a. The equivalent length of elbows, tees, and other fittings are listed in the Friction Loss Table, Table 4:

FITTINGS OR PIPING	FRICTION LOSS EQUIVALENT IN PIPING AND FITTINGS		
	EQUIVALENT FEET		
	2"	3"	4"
90 DEGREE ELBOW*	5'	5'	3'
45 DEGREE ELBOW	3'	3'	1'
COUPLING	0'	0'	0'
AIR INLET TEE	0'	0'	0'
STRAIGHT PIPE	1'	1'	1'
CONCENTRIC VENT KIT	3'	3'	N/A
V500 2" VENT KIT	1'	N/A	N/A
V1000 3" VENT KIT	N/A	1'	1'
V2000 4" VENT KIT	N/A	1'	1'

**Table 4 - \*Friction loss for long radius elbow is 1' less. NOTE: Consult Polypropylene venting instructions for friction loss and pressure drop equivalents.**

- b. For example: If the vent size is 2", and the exhaust vent has two 90° elbows and 10 feet of PVC pipe we will calculate:  
 Exhaust Vent Equivalent Length = (2x5) + 10 = 20 feet.  
 Further, if the intake pipe has two 90° elbows, one 45° elbow and 10 feet of PVC pipe, the following calculation applies:  
 Intake Pipe Equivalent Length = (2x5) + 3 + 10 = 23 feet.  
 Finally, if a concentric vent kit is used we find:  
 Total Equivalent Length = 20 + 23 + 3 = 46 feet.  
 The total equivalent length is 46 feet which is well below the maximum of 85 feet.

3. The minimum total equivalent length is 16 equivalent feet.

## CAUTION

Failure to provide a minimum total vent length of 16 equivalent feet could result in property damage and improper product operation.

### **F. LONGER VENT RUNS**

The maximum total equivalent length can be extended by increasing the diameter of both exhaust vent and intake pipe equally. However, the transitions should begin a minimum of 15 total equivalent feet from the water appliance.

- a. **The maximum total equivalent length for increased diameter vent pipes is 125 feet for 2" transitioning to 3" pipe (this number includes the minimum 15 total equivalent feet necessary for transition), and 200 maximum total equivalent feet for 3" transitioning to 4" pipe (including the minimum 15 total equivalent feet necessary for transition).**
- b. Transitions should always be made in vertical sections of pipe to prevent the condensate from pooling in the vent pipe.

MODEL	MAXIMUM TOTAL EQUIVALENT LENGTH AT STANDARD VENT CONNECTION	REDUCING COUPLING	MAXIMUM TOTAL EQUIVALENT LENGTH AT MAXIMUM INCREASED VENT SIZE
PHE130	85' @ 2"	3" X 2"	125' at 3"
PHE199	200' @ 3"	4" X 3"	200' at 4"

**Table 5 – Vent Sizing – Diameter and Length**



c. If the transition occurs at a distance greater than 15 equivalent feet from the water appliance, the maximum equivalent length will be reduced.

## **DANGER**

Total maximum total equivalent length of increased diameter exhaust vent and intake pipe must not exceed the lengths defined in this manual. 125 maximum total equivalent feet for 2" increased to 3" diameter vent pipe; 200 maximum total equivalent feet for 3" increased to 4" diameter vent pipe. Failure to keep the total equivalent length below the maximum lengths determined in this manual will result in faulty appliance operation, substantial property damage, serious personal injury, or death.

TRANSITION POINT (FT. FROM WATER APPLIANCE)	TEL OF OVERSIZED VENT PIPE (FT.)*	MAXIMUM TEL OF ALL VENT PIPE (FT.)
15	95	125
20	77-1/2	117-1/2
25	60-1/2	110-1/2
30	43	103
35	26	96
40	8-1/2	88-1/2
NONE	0	85

**Table 6 – TEL = Total Equivalent Length \*Oversized vent pipe diameter is 1" or greater than factory supplied connection.**

### **G. EXHAUST VENT AND INTAKE PIPE INSTALLATION**

## **WARNING**

All joints of positive pressure vent systems must be sealed completely to prevent leakage of flue products into living space.

1. Use only solid PVC or CPVC pipe, or a Polypropylene vent system, approved for use with Category IV appliances. **FOAM CORE PIPING IS NOT APPROVED FOR EXHAUST VENT APPLICATIONS.** Foam core piping may be used on air inlet piping **only**.
2. Remove all burrs and debris from joints and fittings.
3. When using PVC or CPVC pipe, all joints must be properly cleaned, primed, and cemented. Use only cement and primer approved for use with the pipe material. Cement must conform to ASTM D2564 for PVC and ASTM F493 for CPVC pipe. **NOTE: DO NOT CEMENT POLYPROPYLENE PIPE.**
4. Ensure the vent is located where it will not be exposed to prevailing winds.
5. In all roof venting applications, exhaust discharge must point away from the pitch of the roof.
6. If the exhaust vent is to be terminated in a walled off area (such as a roof with a parapet wall), ensure the exhaust vent terminates a minimum of 10' from nearest wall and extends level with or above the top of the wall. This will ensure flue gas does not get trapped and possibly recirculated into the intake air pipe, which could contaminate the combustion air.
7. To prevent water leakage, install adequate roof flashing where the pipe enters the roof.
8. Do not locate vent over public walkways, driveways, or parking lots. Condensate could drip and freeze, resulting in a slip hazard or damage to vehicles and machinery.
9. Due to potential moisture build-up, sidewall venting may not be the preferred venting option. To save time and cost, carefully consider venting installation and location.
10. Horizontal lengths of exhaust vent must slope back towards the appliance not less than ¼" per foot to allow condensate to drain from the vent pipe.
11. The exhaust vent must terminate where vapors cannot make accidental contact with people or pets, or damage shrubs or plants.
12. In vacant chimney applications, install and seal a rain cap over existing chimney openings.
13. All piping must be fully supported. Use pipe hangers at a minimum of 4 foot intervals to prevent sagging of the pipe where condensate may form.
14. Do not use the appliance to support any piping.
15. A screened straight coupling is provided with the appliance for use as an outside exhaust termination.

16. A screened inlet air tee is provided with the appliance to be used as an outside intake termination.

Table 7 lists optional intake air/exhaust vent terminations available from HTP:

VENT TERMINATION KITS	
DESCRIPTION	STOCK CODE
2" PVC CONCENTRIC VENT TERMINATION KIT	KGAVT0501CVT
3" PVC CONCENTRIC VENT TERMINATION KIT	KGAVT0601CVT
2" STAINLESS STEEL VENT TERMINATION KIT	V500
3" STAINLESS STEEL VENT TERMINATION KIT	V1000
4" STAINLESS STEEL VENT TERMINATION KIT	V2000
3" POLYPRO VENT KIT	8400P-001

Table 7

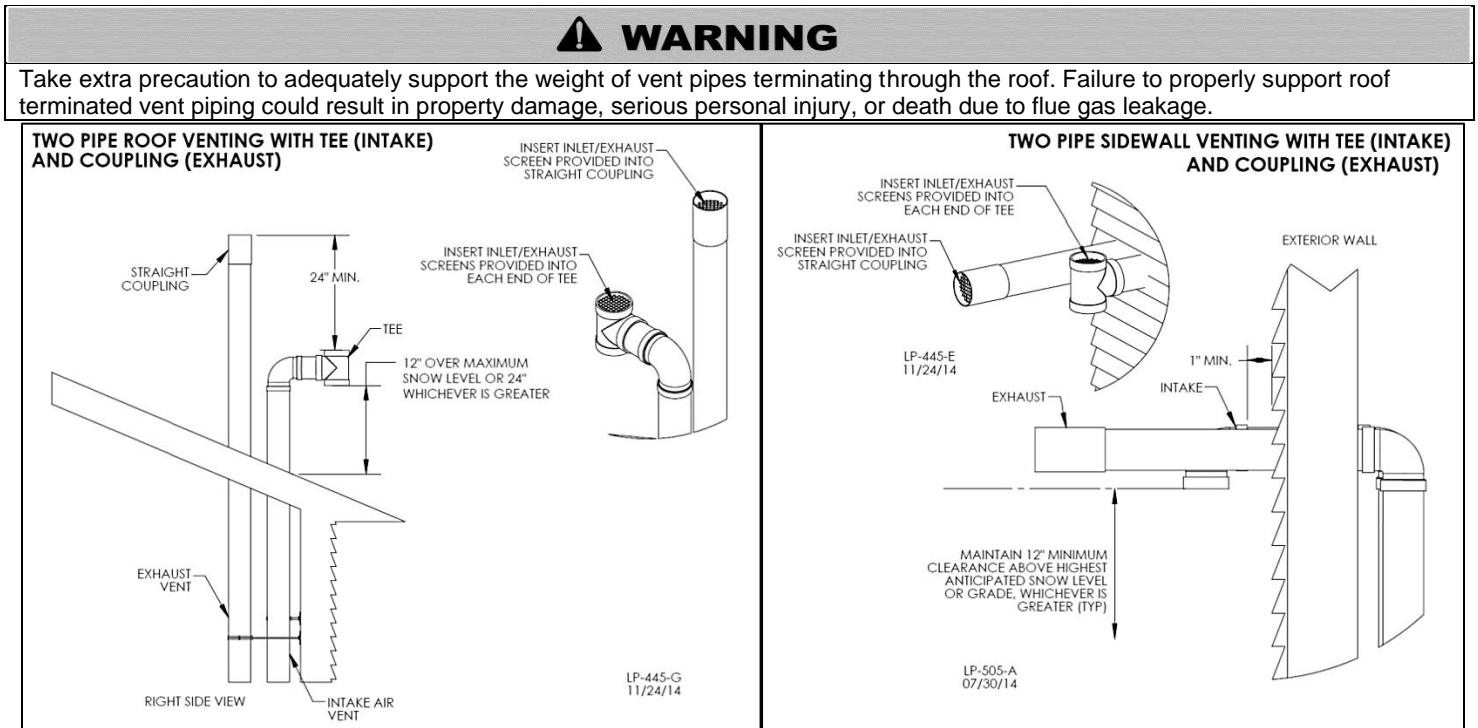
**H. VENTING DRAWINGS**

**1. DIRECT VENT INSTALLATION OF EXHAUST VENT AND INTAKE PIPE**

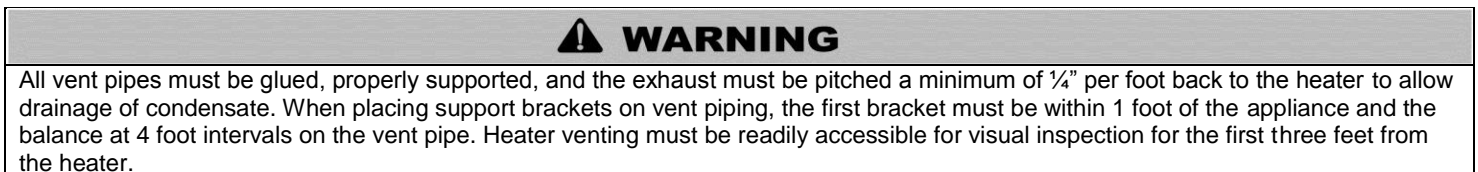
If installing a direct vent option, combustion air must be drawn from the outdoors directly into the appliance intake, and exhaust must terminate outside. There are three basic direct vent options detailed in this manual: 1. Side Wall Venting, 2. Roof Venting, and 3. Unbalanced Venting.

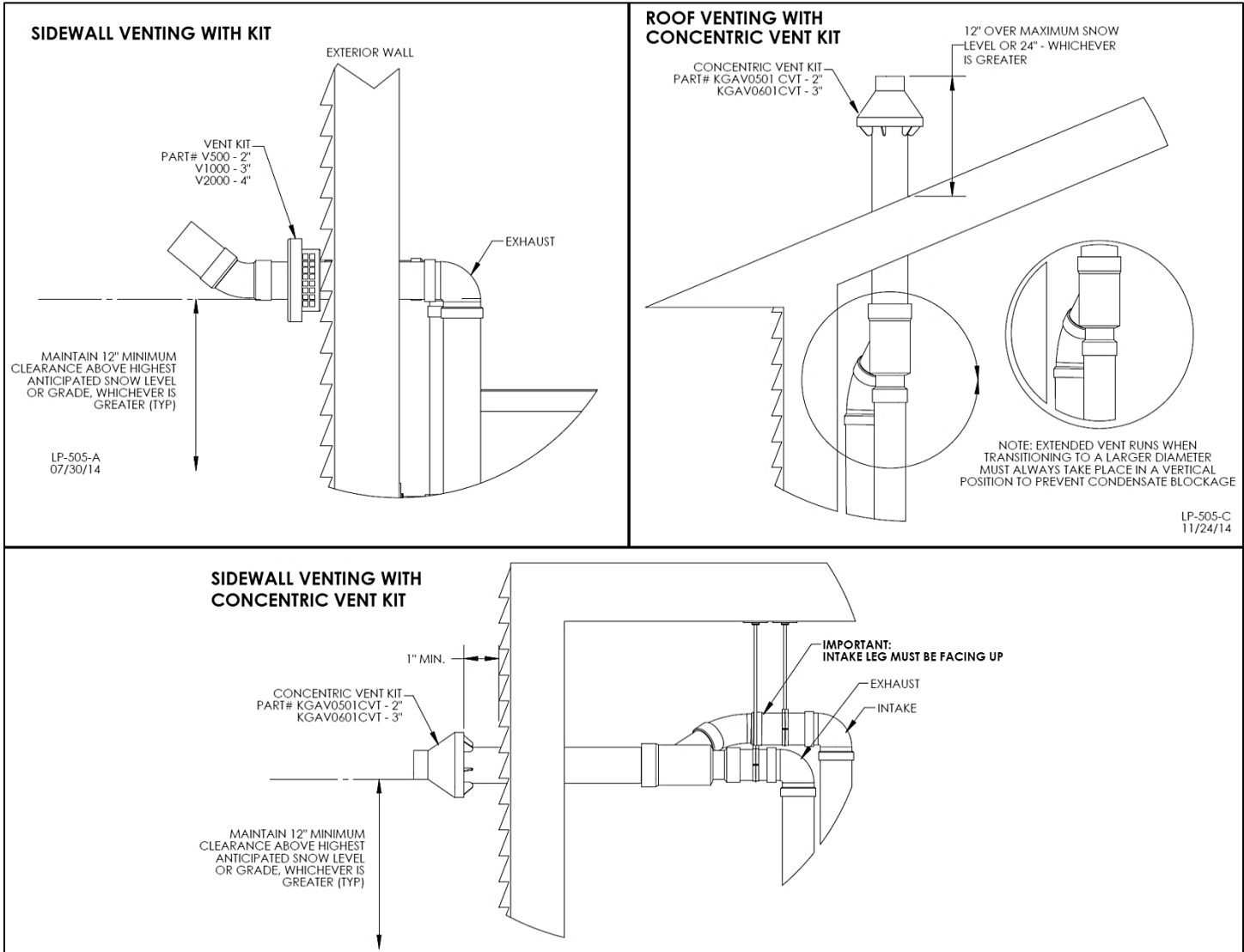
Be sure to locate the appliance such that the exhaust vent and intake piping can be routed through the building and properly terminated. Different vent terminals can be used to simplify and eliminate multiple penetrations in the building structure (see Optional Equipment in Venting Section). The exhaust vent and intake piping lengths, routing and termination methods must all comply with the methods and limits given in the Venting section, Part 6 of this manual.

When installing a combustion air intake from outdoors, care must be taken to utilize uncontaminated combustion air. **NOTE: To prevent combustion air contamination, see Table 1.**



**Figure 15 – Two Pipe Roof and Sidewall Venting with Included Equipment (Tee and Coupling) - NOTE: These drawings are meant to demonstrate system venting only. The installer is responsible for all equipment and detailing required by local codes.**

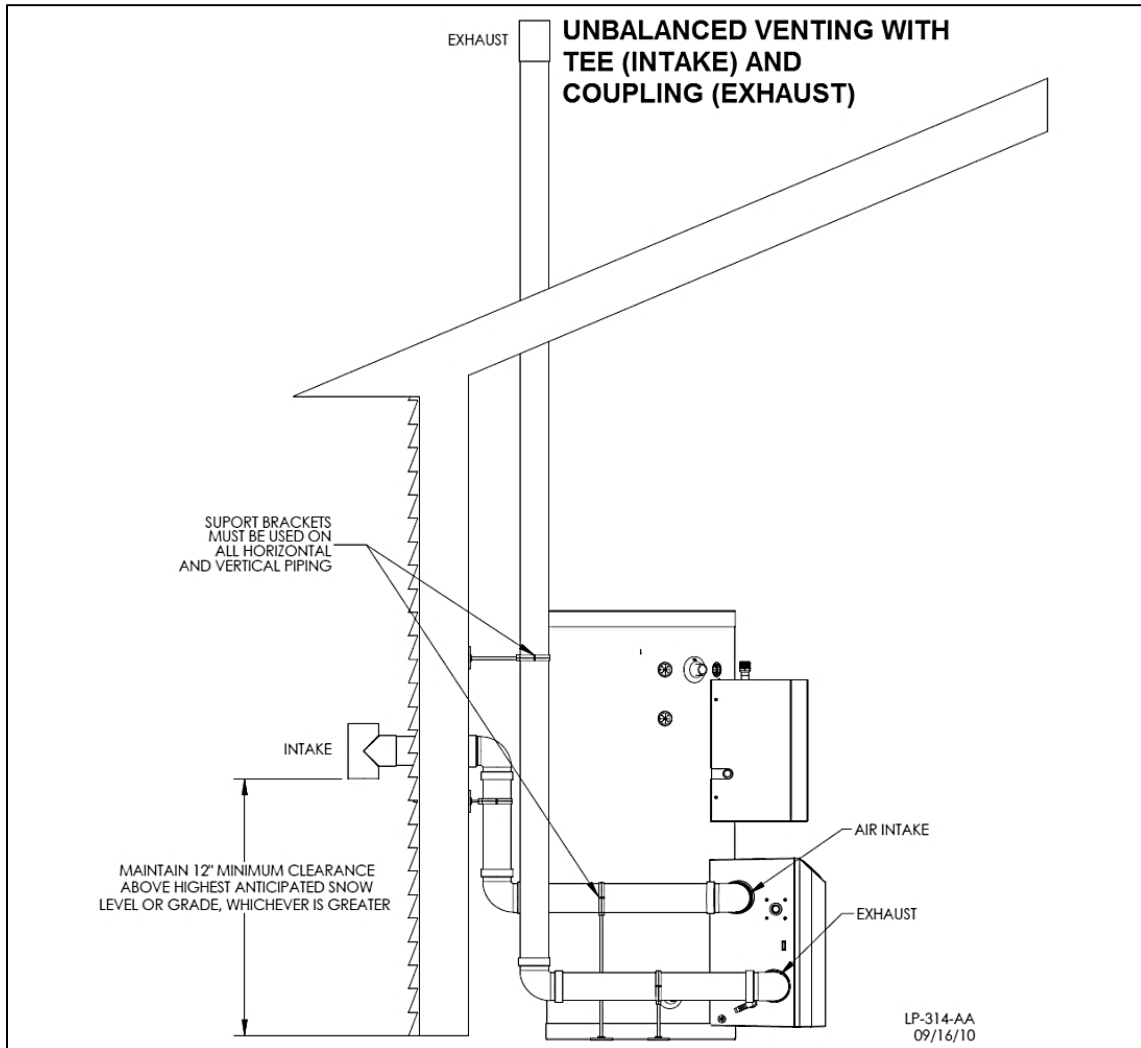




**Figure 16 – Venting with Optional Kits (NOT INCLUDED WITH THE APPLIANCE) NOTE: These drawings are meant to demonstrate system venting only. The installer is responsible for all equipment and detailing required by local codes.**

**⚠ WARNING**

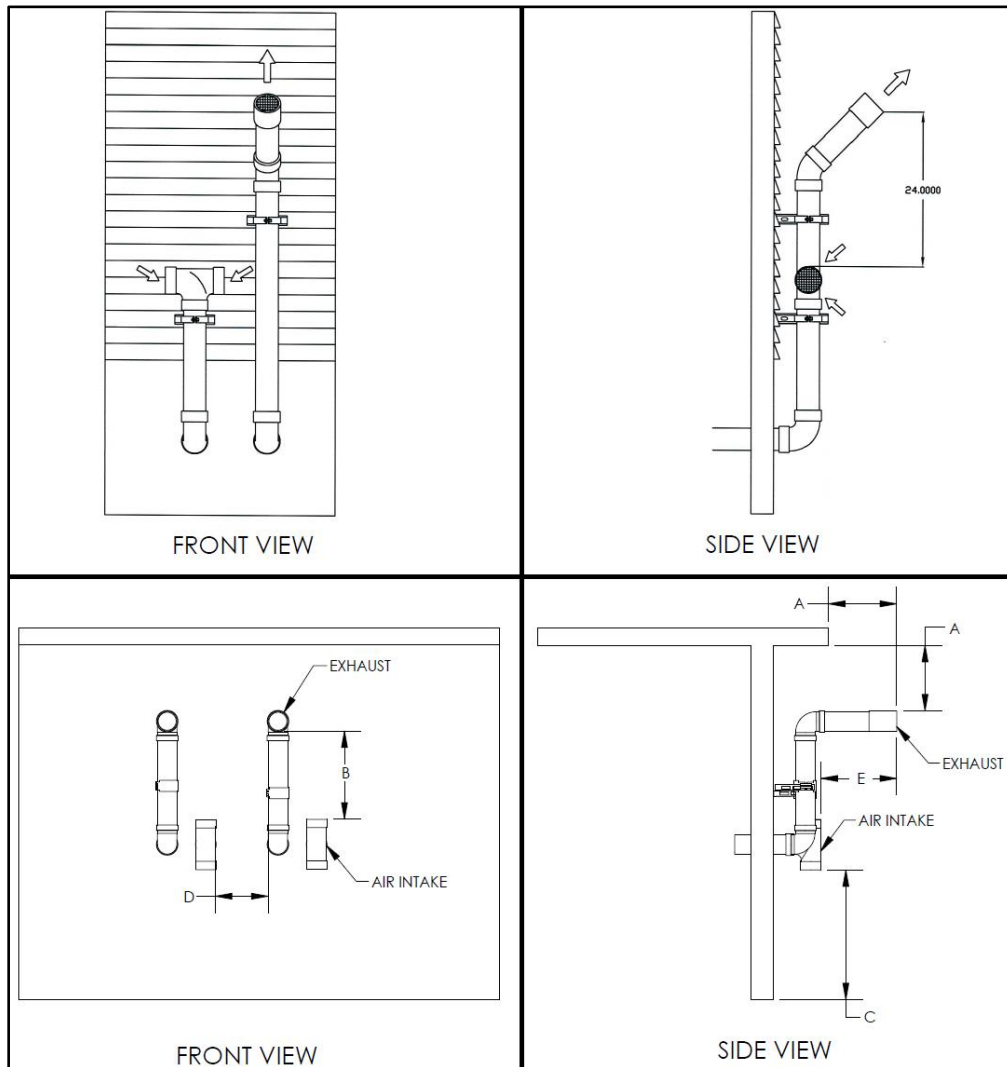
All vent pipes must be glued, properly supported, and the exhaust must be pitched a minimum of 1/4" per foot back to the heater to allow drainage of condensate. When placing support brackets on vent piping, the first bracket must be within 1 foot of the appliance and the balance at 4 foot intervals on the vent pipe. Heater venting must be readily accessible for visual inspection for the first three feet from the heater.



**Figure 17 – NOTE: This drawing is meant to demonstrate system venting only. The installer is responsible for all equipment and detailing required by local codes.**

### **⚠ WARNING**

All vent pipes must be glued, properly supported, and the exhaust must be pitched a minimum of  $\frac{1}{4}$ " per foot back to the heater to allow drainage of condensate. When placing support brackets on vent piping, the first bracket must be within 1 foot of the appliance and the balance at 4 foot intervals on the vent pipe. Heater venting must be readily accessible for visual inspection for the first three feet from the heater.



**Figure 18 – Horizontal Venting - NOTE: Drawing is meant to demonstrate system venting ONLY.**

**NOTES:**

- A. For every 1” of overhang, the exhaust vent must be located 1” vertical below overhang (overhang means top of building structure and not two adjacent walls [corner of building]).
- B. Typical installations require 12” minimum separation between bottom of exhaust outlet and top of air intake.
- C. Maintain 12” minimum clearance above highest anticipated snow level or grade (whichever is greater).
- D. Minimum 12” between vents when installing multiple vents.
- E. 12” minimum beyond air intake.

**⚠ WARNING**

All vent pipes must be glued, properly supported, and the exhaust must be pitched a minimum of 1/4” per foot back to the appliance to allow drainage of condensate. When placing support brackets on vent piping, the first bracket must be within 1 foot of the appliance and the balance at 4 foot intervals on the vent pipe. Appliance venting must be readily accessible for visual inspection for the first three feet from the appliance.

**2. VENTING THROUGH AN EXISTING SYSTEM**

This heater may be vented through an existing unused vent system. The inner diameter of the existing vent system is utilized for the combustion air source. Two methods have been approved for such venting: Concentric Venting Through an Existing System and Venting as a Chase.

VENT / AIR INLET SIZE	MINIMUM EXISTING VENT / CHASE SIZE
2”	4”
3”	5”
4”	7”

**Table 8 – Minimum Existing Vent / Chase Sizing**

**! DANGER**

Do not install the heater into a common existing vent with any other appliance. This will cause flue gas spillage or heater malfunction, resulting in substantial property damage, severe personal injury, or death.

**CAUTION**

Contractors must check state and local codes before installing through an existing vent opening. State and local codes always take precedence over manufacturer's instructions. Failure to check state and local codes before installing through an existing opening could result in property damage and add significantly to installation costs.

**CAUTION**

If an existing venting system is converted for use with this heater, the installer must ensure that the existing venting system is clean and free from particulate contamination that could damage the heater. Failure to do so could result in property damage and heater failure. Such failure IS NOT covered under warranty.

**CONCENTRIC VENTING THROUGH AN EXISTING SYSTEM**

**NOTE:** The following instructions refer only to venting through an existing vent system, and not to venting with HTP's optional concentric vent kits. Refer to Concentric Vent Kit installation manual (LP-166) for further information on venting with the optional concentric vent kits.

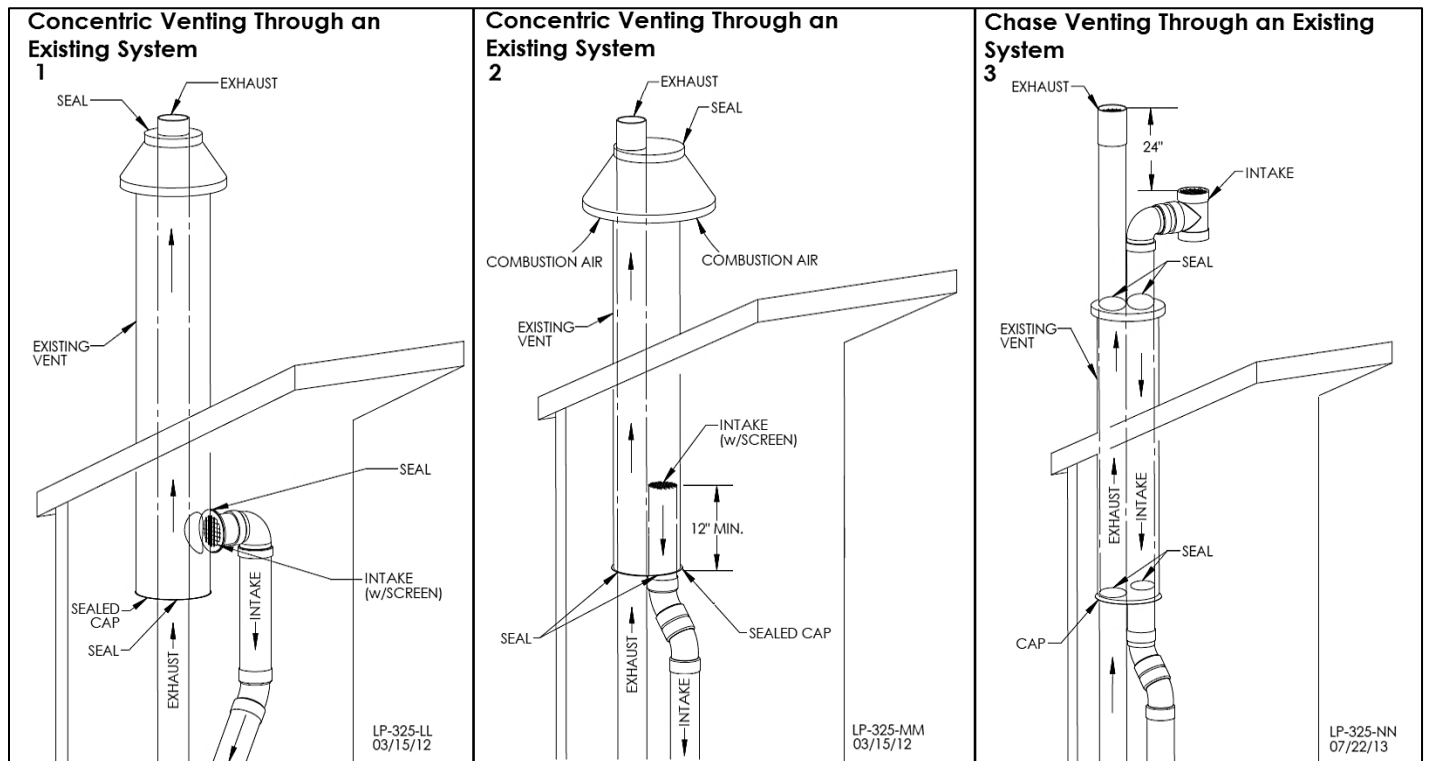
Concentric venting through an existing system must run vertically through the roof. See Table 8 for proper minimum vent sizing. Use only the approved venting materials specified in Table 3 for piping the system. All instructions listed in the Venting section apply. See Figures 19-1 and 19-2 for venting demonstrations.

**! DANGER**

The upper and lower vent terminations as well as all joints in the venting system must be properly sealed to ensure that all combustion air is drawn properly and exhaust does not leak from the system. Failure to properly seal the venting system will result in property damage, severe personal injury, or death.

**CHASE VENTING THROUGH AN EXISTING SYSTEM**

When venting as a chase, follow all instructions included in the Venting section of this manual, as well as the previous Concentric Venting section. See Figure 19-3 for chase venting demonstration.



Figures 19 – 1, 19 – 2 Concentric Venting Through an Existing System, 19 – 3 Chase Venting Through an Existing System **NOTE:** This drawing is meant to demonstrate system venting only. The installer is responsible for all equipment and detailing required by local codes.

**3. INDOOR COMBUSTION AIR INSTALLATION IN CONFINED OR UNCONFINED SPACE**

This heater requires fresh, uncontaminated air for safe operation and must be installed in a mechanical room where there is adequate combustion and ventilating air. **NOTE: To prevent combustion air contamination, see Table 1.**

Combustion air from the indoor space can be used if the space has adequate area or when air is provided through a duct or louver to supply sufficient combustion air based on the appliance input. **Never obstruct the supply of combustion air to the appliance.** If the appliance is installed in areas where indoor air is contaminated (see Figure 20) it is imperative that the appliance be installed as direct vent so that all combustion air is taken directly from the outdoors into the appliance intake connection.

**Unconfined space** is space with volume greater than 50 cubic feet per 1,000 Btu/hour (4.8 cubic meters per kW) of the total input rating of all fuel-burning appliances installed in that space. Rooms connected directly to this space, through openings not furnished with doors, are considered part of the space.

**Confined space** is space with volume less than 50 cubic feet per 1,000 Btu/hour (4.8 cubic meters per kW) of the total input rating of all fuel-burning appliances installed in that space. Rooms connected directly to this space, through openings not furnished with doors, are considered part of the space.

When drawing combustion air from inside a conventionally constructed building to a confined space, such space should be provided with two permanent openings: one located 6" (15 cm) below the space ceiling, the other 6" (15cm) above the space floor. Each opening should have a free area of one square inch per 1,000 Btu/hr (22cm<sup>2</sup>/kW) of the total input of all appliances in the space, but not less than 100 square inches (645cm<sup>2</sup>).

If the confined space is within a building of tight construction, air for combustion must be obtained from the outdoors as outlined in the Venting section of this manual. See Figure 21.

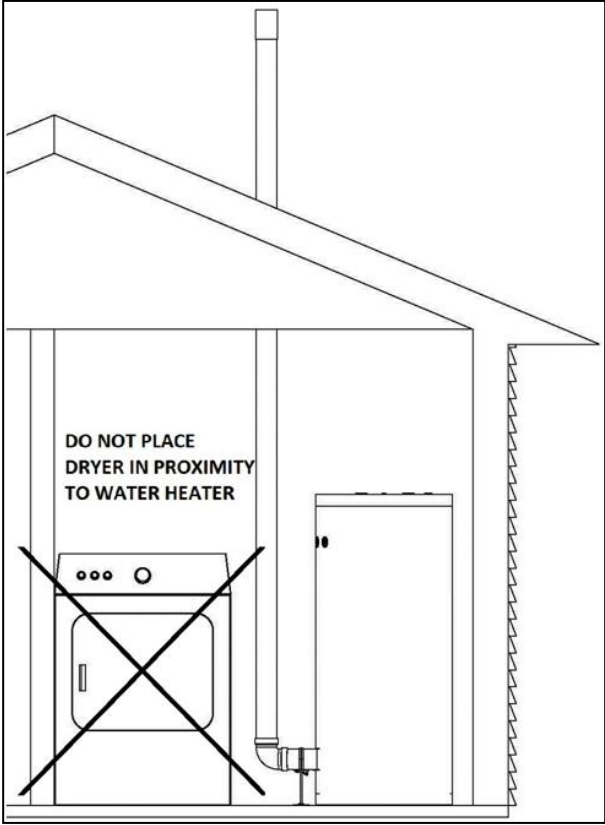
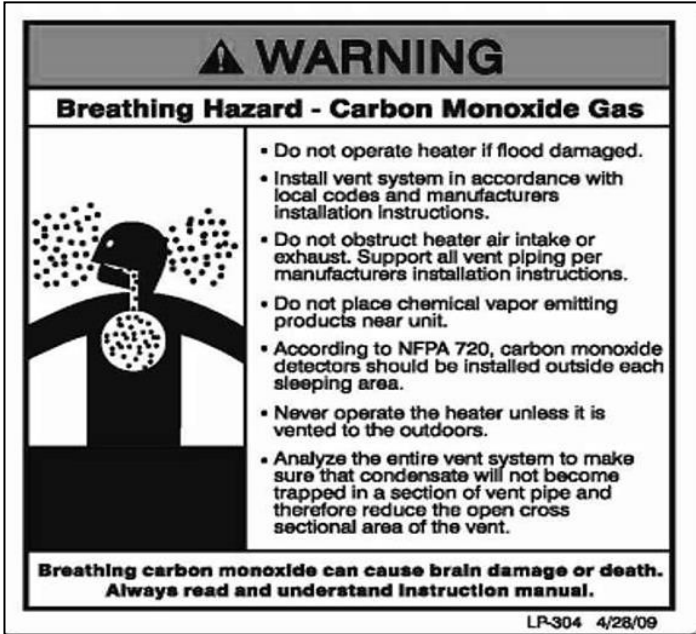


Figure 20 – LP-325-X

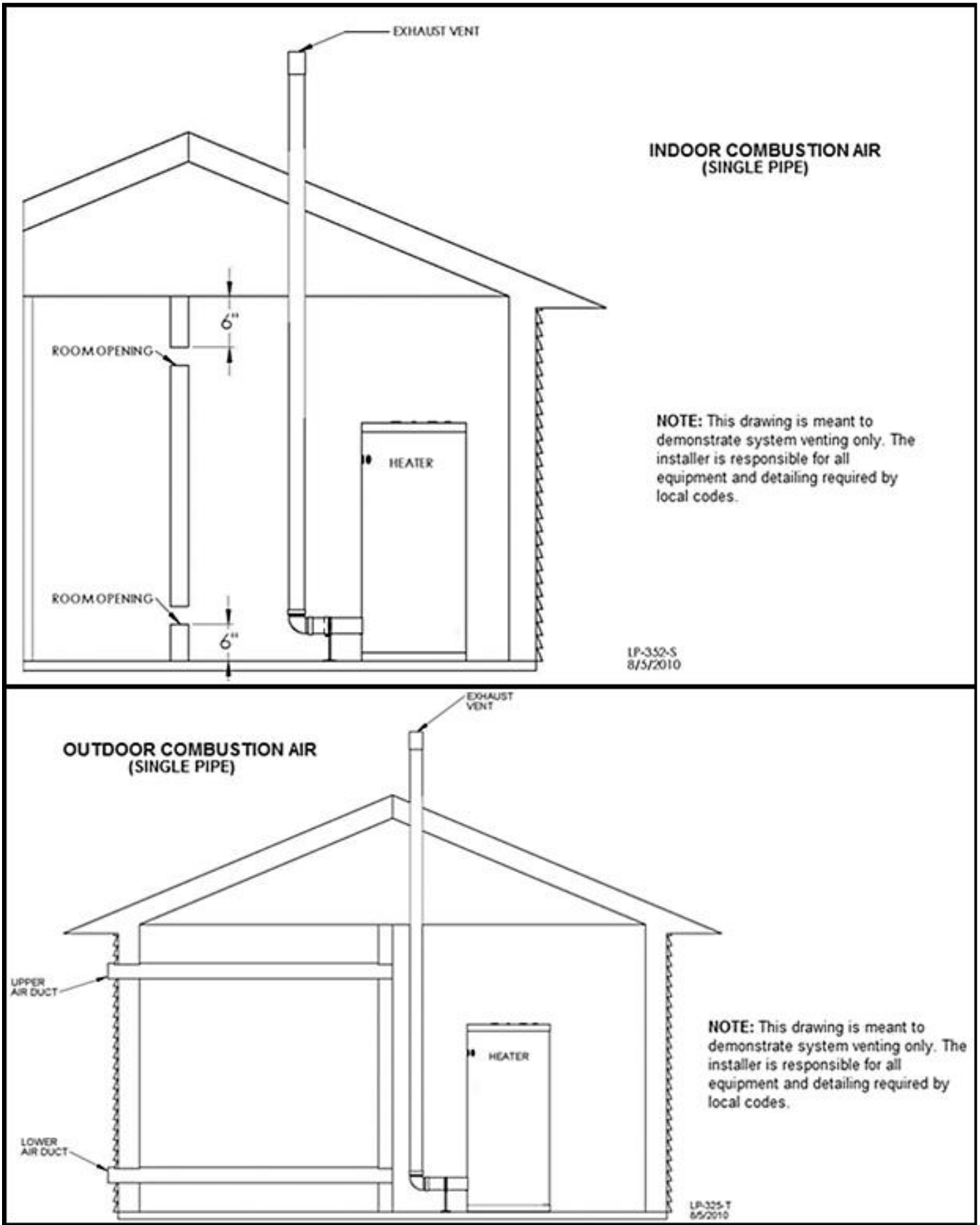


Figure 21



## **I. CONDENSATE REMOVAL SYSTEM**

**NOTE:** Check with your local gas company to determine if combustion condensate disposal is permitted in your area. In the state of Massachusetts, condensate must be neutralized before entering a drain.

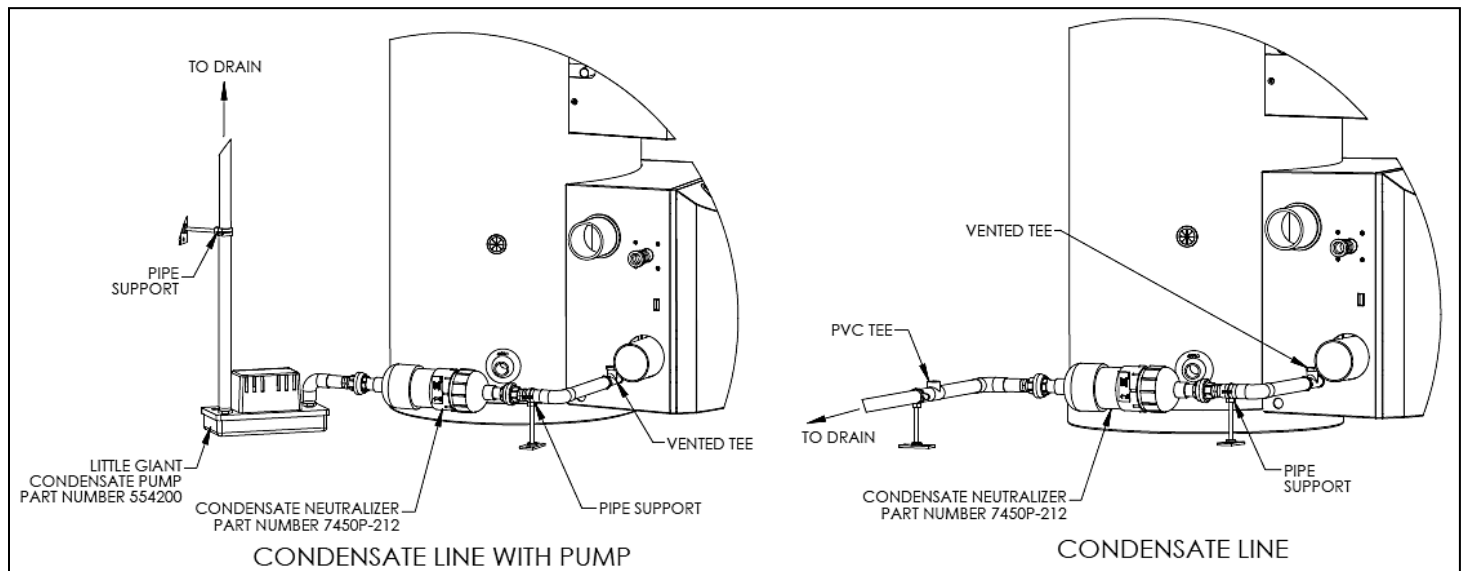
This condensing high efficiency appliance has a condensate removal system. Condensate is water vapor derived from combustion products, similar to an automobile when it is initially started. It is very important that the condensate line is sloped down away from the appliance and to a suitable drain.

If the appliance condensate outlet is lower than the drain, you must use a condensate removal pump (kit p/n 554200 available from HTP). If required by local authorities, a condensate filter of lime crystals, marble, or phosphate chips will neutralize slightly acidic condensate. This can be installed in the field and purchased from HTP (p/n 7450P-212).

Plastic pipe must be the only material used for the condensate line. Steel, brass, copper or other materials will be subject to corrosion or deterioration. A second vent may be necessary to prevent a condensate line vacuum lock if a long horizontal run is used. An increase in condensate line diameter may be necessary to allow condensate to drain properly. Support of the condensate line may be necessary to avoid blockage of the condensate flow.

### **CAUTION**

The condensate line must remain unobstructed. If allowed to freeze in the line or obstructed in any other manner, condensate can exit from the tee, resulting in potential water damage to property. When installing a condensate pump, select one approved for use with condensing appliances and furnaces. The condensate pump should have an overflow switch to prevent property damage from spillage. Condensate from the appliance will be slightly acidic (pH from 3.2 to 4.5). Install a neutralizing filter if required by local codes.



**Figure 22 – Installation of Condensate Line - LP-314-BB**

#### **NOTES:**

1. CONDENSATE LINE MUST BE PITCHED AT LEAST  $\frac{1}{4}$ " PER FOOT TO PROPERLY DRAIN. IF THIS CANNOT BE DONE, OR A VERY LONG LENGTH OF CONDENSATE HOSE IS USED, INCREASE THE CONDENSATE LINE TO A MINIMUM OF 1" ID AND PLACE A TEE IN THE LINE AFTER THE CONDENSATE NEUTRALIZER. THIS WILL REDUCE VACUUM LOCK.
2. PLASTIC PIPE SHOULD BE THE ONLY MATERIAL USED FOR THE CONDENSATE LINE. STEEL, BRASS, COPPER, OR OTHER MATERIALS WILL BE SUBJECT TO CORROSION OR DETERIORATION.
3. NEVER install condensate lines outside. It is very important that the condensate line is not exposed to freezing temperatures or any type of blockage. Damages due to frozen or blocked condensate lines ARE NOT covered by warranty.
4. Support of the condensate line may be necessary to avoid blockage of the condensate flow.

## PART 7 - FIELD WIRING

### WARNING

To avoid electrical shock, turn off all power to the appliance prior to opening an electrical box within the unit. Ensure the power remains off while any wiring connections are being made. Failure to follow these instructions could result in component or product failure, serious injury, or death. Such product failure IS NOT covered by warranty.

#### **A. FIELD WIRING COMPLIANCE REQUIREMENTS**

### WARNING

ELECTRICAL SHOCK HAZARD – For your safety, to avoid possible electrical shock hazard, turn off electrical power supply at service entrance panel before making any electrical connections. Failure to do so can result in severe personal injury or death.

**NOTE:** Wiring must be N.E.C. Class 1. If original wiring as supplied with appliance must be replaced, use only TEW 105 °C wire or equivalent. Appliance must be electrically grounded as required by National Electrical Code ANSI/NFPA 70 – latest edition.

#### **INSTALLATION MUST COMPLY WITH:**

1. National Electrical Code and any other national, state, provincial or local codes or regulations.
2. In Canada, CSA C22.1 Canadian Electrical Code Part 1, and any local codes.

#### **B. FIELD WIRING**

All the wiring connections made to the appliance in the field are done on the field connection board located on the right side of the cabinet. The cabinet has multiple knockouts available to route field wiring into and out of the field connection board. The control provides a pump output thermostat and outdoor sensor inputs to operate the central heating system.

#### **C. LINE VOLTAGE WIRING**

1. Connect the normal **incoming power** to the terminals marked as shown in Figure 24. A line voltage fused disconnect switch may be required to be externally mounted and connected according to local codes and standards.
2. Connect the **central heating pump** as shown in the terminals marked CH/DHW PUMP (see Figure 24). The connections shown are suitable for a maximum continuous pump draw of 3 amps at 120 volts. If the pump requires more current or voltage than the 120 volts supplied, an external motor starter will be required.
3. Connect the **NHX pump (if applicable)** as shown in the terminals marked NHX PUMP (see Figure 24). The connections shown are suitable for a maximum continuous pump draw of 3 amps at 120 volts. If the pump requires more current or voltage than the 120 volts supplied, an external motor starter will be required.

#### **D. LOW VOLTAGE WIRING**

1. Make all low voltage connections to the terminal strip located on the field connection board (shown in Figure 23) as outlined below.
2. The **room thermostat** should be connected to the terminals marked T STAT (shown in Figure 23). Alternately, any dry contact closure across these terminals will cause the unit to operate the hydronic heating module. NOTE: Caution must be used to ensure neither of the terminals becomes connected to ground. Mount the thermostat on an inside wall as central as possible to the area being heated, away from drafts or heat producing devices such as a television, which could influence the ability of the thermostat to measure room temperature accurately. NOTE: If the thermostat is equipped with a directly connected anticipator, the anticipator should be set at .1 amps. If the thermostat is connected to other devices, the anticipator should be set to match the power requirements of those connected devices. Refer to the instruction manuals of the connected devices for further information.
3. The **outdoor sensor** must be connected for the unit to operate at optimum efficiency. Use a minimum 22 AWG wire for runs of 100 feet or less and minimum 18 AWG wire for runs up to 150 feet. Instructions are included with the outdoor sensor to correctly mount the sensor on the exterior surface of the building. It is preferable to mount the sensor on the north side in an area that will not be affected by direct sunlight but will be exposed to varying weather conditions. Connect the outdoor sensor to terminals marked "Outdoor" in Figure 23.

#### **E. FIELD CONNECTION BOARD**

### CAUTION

Label all wires prior to disconnecting them when servicing the appliance. Wiring errors can cause improper and dangerous operation. Failure to follow these instructions may result in property damage or personal injury.

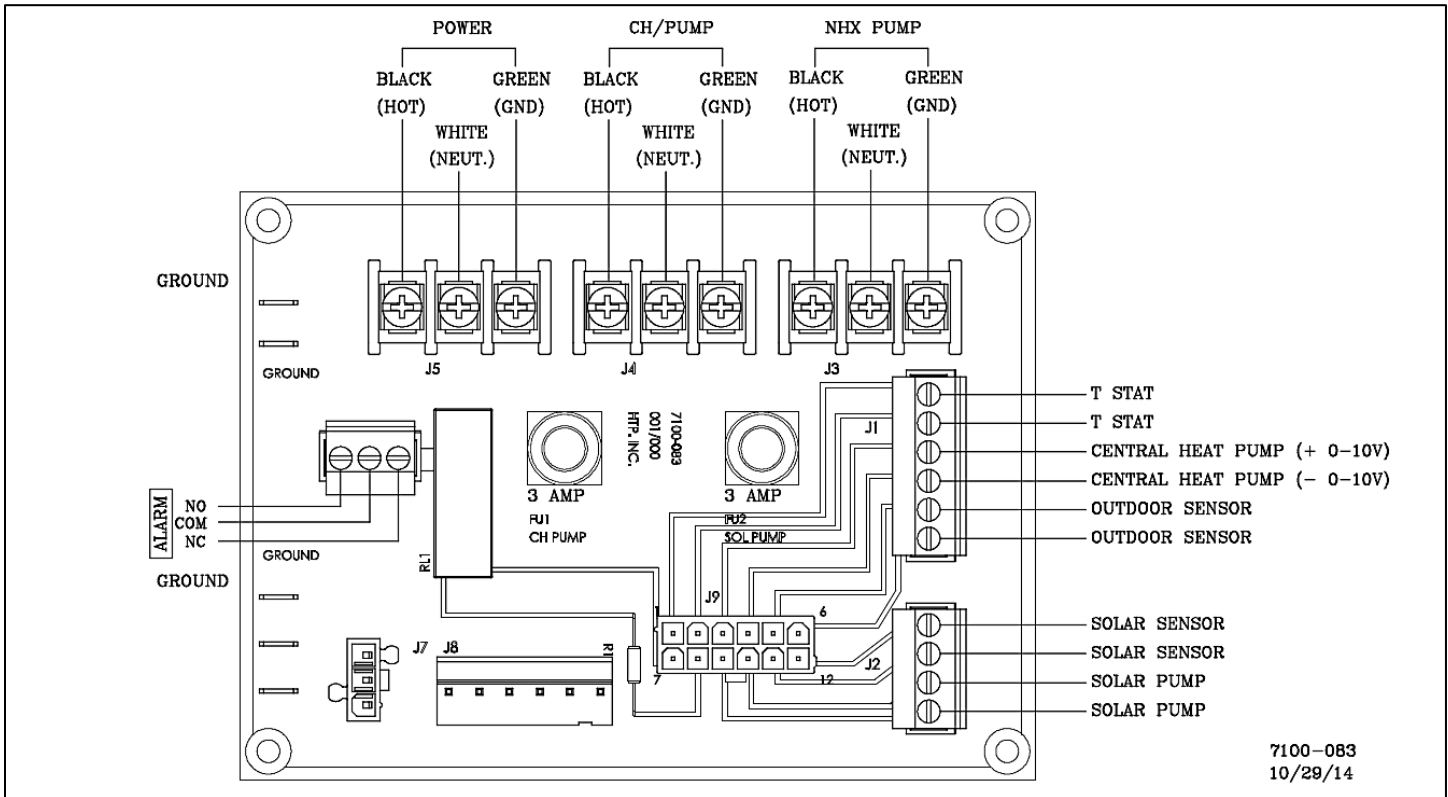
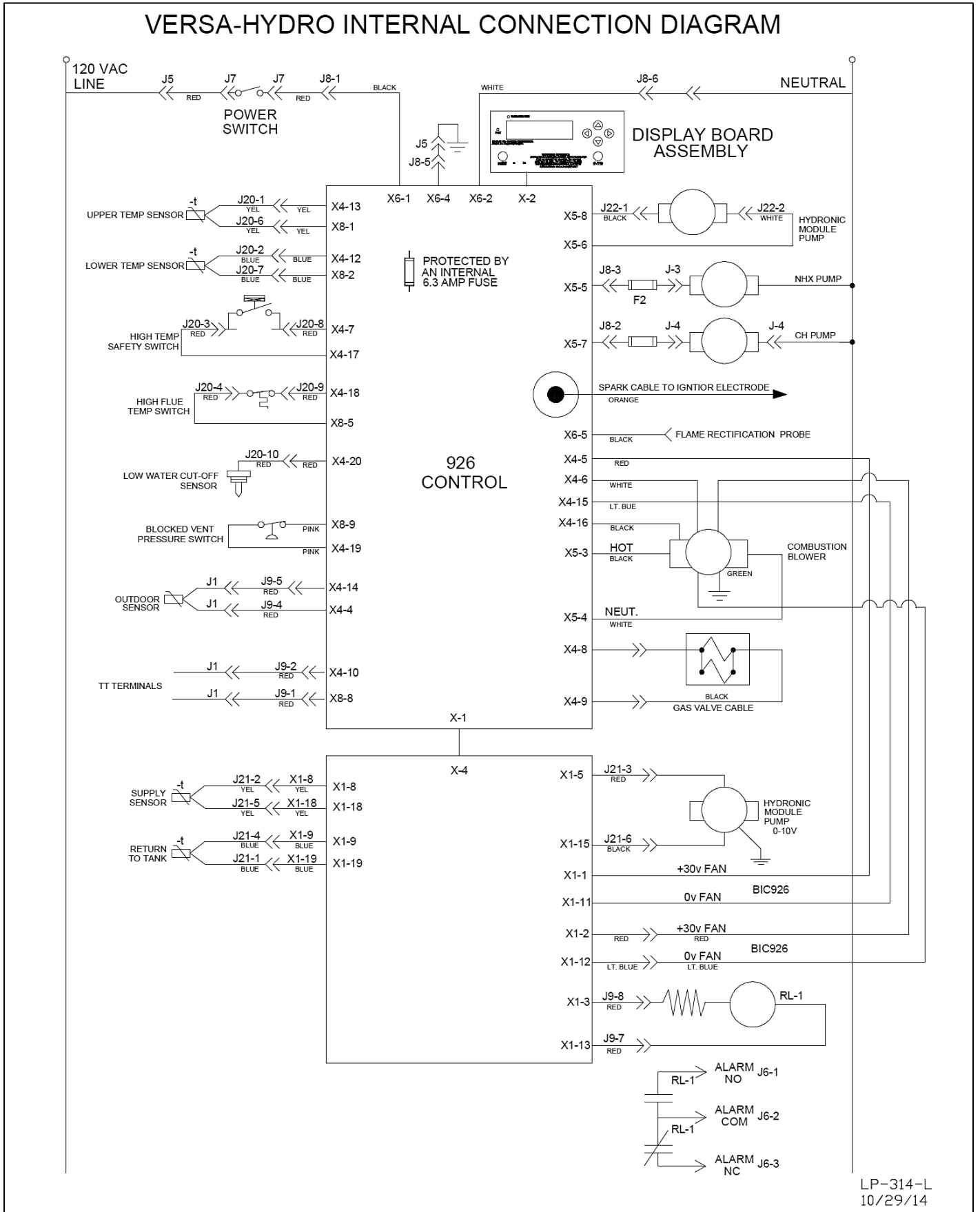


Figure 23 – Customer Connection Board

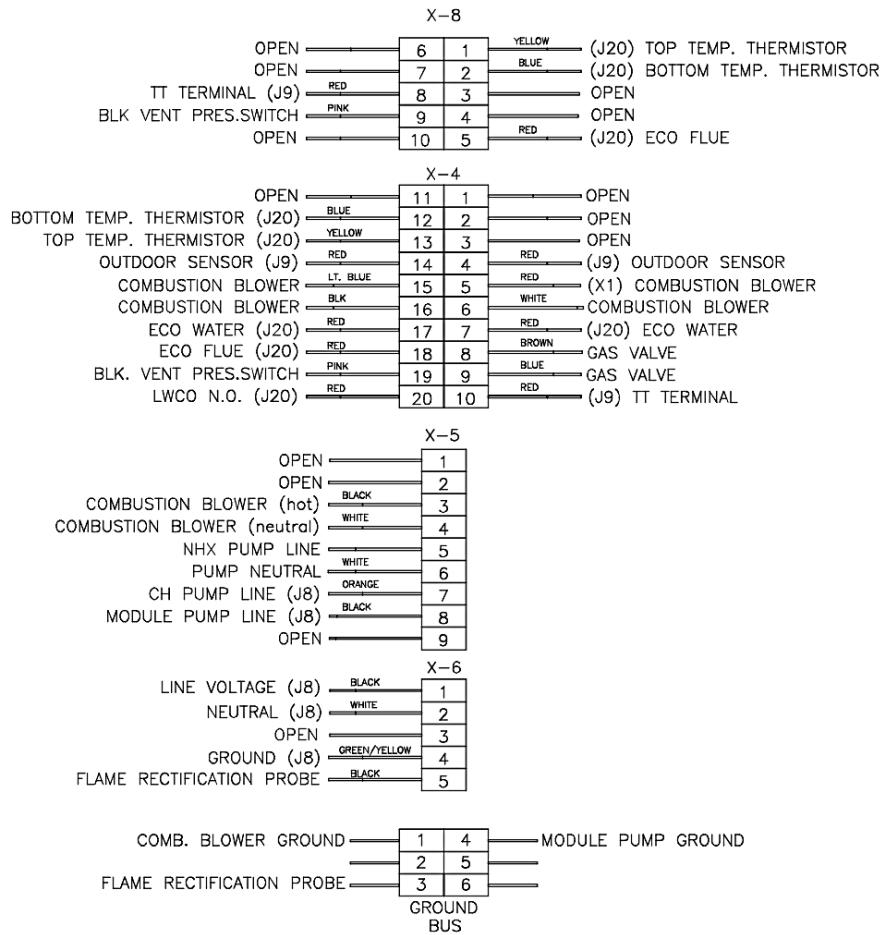
F. INTERNAL WIRING



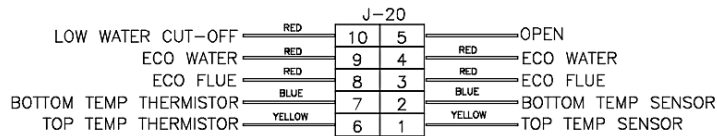
LP-314-L  
10/29/14

Figure 24 – Internal connection diagram

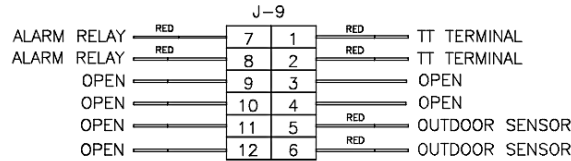
### VERSA-HYDRO CONTROL BOARD



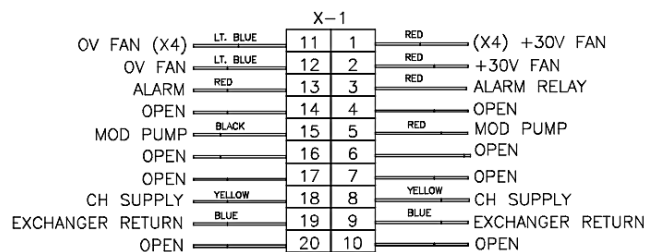
### EXTERNAL 10 PIN CONNECTOR



### VERSA-HYDRO FEILD CONNECTION BOARD



### VERSA-HYDRO ECS BOARD



LP-314-R  
10/29/14

Figure 25 – LP-314-R

**⚠ WARNING**

It is of extreme importance that this unit be properly grounded. Prior to making any electrical connections, It is very important that the building system ground is inspected by a qualified electrician. Make certain that electrical power is only turned on when the unit is completely filled with cold water.

**PART 8 - GAS CONNECTION**

**⚠ WARNING**

Failure to follow all precautions in this section could result in fire, explosion, or death!

**A. GAS SUPPLY**

The gas supply shall have a maximum inlet pressure of less than 14" water column (350 mm), ½ pound pressure (3.5 kPa), and a minimum of 3.5" water column (WC). As stated in the National Fuel Gas Code, the entire piping system, gas meter, and regulator must be sized properly to prevent pressure drop greater than .5" WC. This information is listed on the unit rating plate.

It is very important that you are connected to the type of gas noted on the rating plate: "LP" for liquefied petroleum, propane gas, or "Nat" for natural or city gas. Prior to turning the gas supply on, all gas connections must be approved by the local gas supplier or utility in addition to the governing authority. **Do not remove the reducing coupling attached to the gas valve! Per the National Fuel Gas Code, it is mandatory that this fitting be used for connection to a field fabricated drip leg as shown in the illustration at left.**

Ensure that the entire gas line to the connection at the appliance is no smaller than ¾". Once all inspections have been performed, the piping must be leak tested. If the leak test requirement is a higher test pressure than the maximum gas inlet pressure, you must isolate the appliance from the gas line to continue leak testing. In order to do this, you must turn off the factory and field-installed gas cocks. This will minimize the possibility of damaging the appliance gas valve.

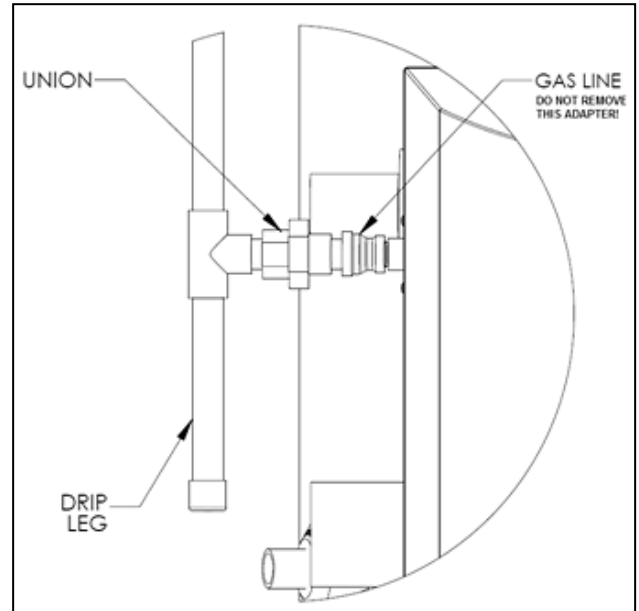


Figure 26

**⚠ WARNING**

Failure to isolate gas line while leak testing may damage the gas valve. In the event the gas valve is exposed to a pressure greater than ½ psi, 14" water column, the gas valve must be replaced. Never use an open flame (match, lighter, etc.) to check gas connections.

**B. GAS PIPING**

1. Run the gas supply line in accordance with all applicable codes.
2. Locate and install manual shutoff valves in accordance with state and local requirements.

**C. GAS TABLE**

Refer to the following table to size the supply piping to minimize pressure drop between meter or regulator and unit.

Maximum capacity of pipe in cubic feet of gas per hour for gas pressures of .5 psi or less and a pressure drop of .3" water column:

Gas Table

Nominal Iron Pipe Size (inches)	Internal Diameter (inches)	Length of Pipe (Feet)															BTU'S PER HOUR x1,000
		10	20	30	40	50	60	70	80	90	100	125	150	175	200		
3/4	.824	278	190	152	130	115	105	96	90	84	79	72	64	59	55	}	
1	1.049	520	350	285	245	215	195	180	170	160	150	130	120	110	100		
1 1/4	1.380	1,050	730	590	500	440	400	370	350	320	305	275	250	225	210		
1 1/2	1.610	1,600	1,100	890	760	670	610	560	530	490	460	410	380	350	320		


Table 9

It is recommended that a soapy solution be used to detect leaks. Bubbles will appear on the pipe to indicate a leak is present. To avoid excessive pressure drop, the gas piping must be sized for the proper flow and length of pipe. Both the gas meter and regulator must be properly sized for the total gas load. If you experience a pressure drop greater than 1" WC, the meter, regulator, and/or gas line is undersized or needs service. By removing the cap, you can attach a manometer to the incoming gas drip leg. The gas pressure must remain between 3.5" WC and 14" WC during stand-by (static) mode and while in operating (dynamic) mode at full output. **If an in-line regulator is used, it must be installed a minimum of 10 feet from the appliance.**

**It is very important that the gas line is properly purged by the gas supplier or utility. Failure to properly purge or size the lines will result in ignition failure.** This problem is especially noticeable in NEW LP installations and empty tank situations. This can also occur when a utility company shuts off service to an area to provide maintenance to their lines. The gas valve must not be replaced with a conventional gas valve under any circumstances. As an additional service feature, the gas valve in this appliance has a flanged connection to the swirl plate and blower.

**⚠ WARNING**

**Breathing Hazard - Carbon Monoxide Gas**

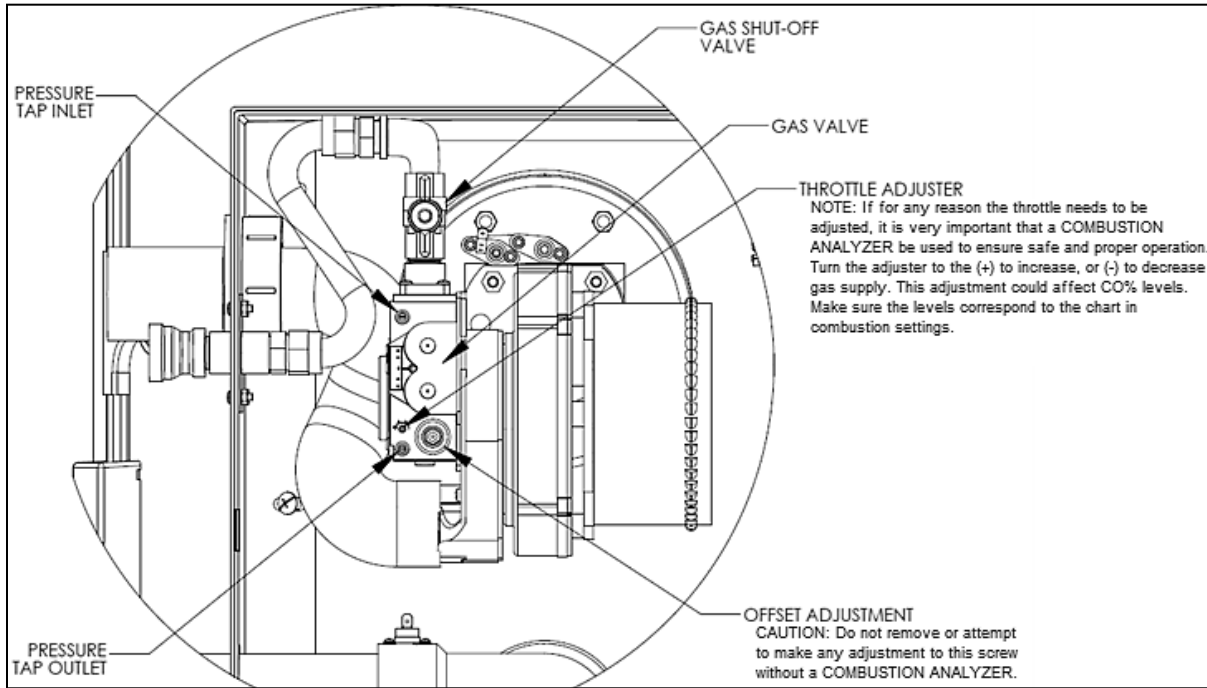


- Do not operate heater if flood damaged.
- Install vent system in accordance with local codes and manufacturers installation instructions.
- Do not obstruct heater air intake or exhaust. Support all vent piping per manufacturers installation instructions.
- Do not place chemical vapor emitting products near unit.
- According to NFPA 720, carbon monoxide detectors should be installed outside each sleeping area.
- Never operate the heater unless it is vented to the outdoors.
- Analyze the entire vent system to make sure that condensate will not become trapped in a section of vent pipe and therefore reduce the open cross sectional area of the vent.

**Breathing carbon monoxide can cause brain damage or death. Always read and understand instruction manual.**

LP-304 4/28/09

**D. GAS VALVE**



**Figure 27 – LP-314-M**

**⚠ DANGER**

Do not do a gas conversion on this appliance without an officially approved conversion kit and instructions supplied by HTP. Failure to use a conversion kit when converting the appliance to fire on Natural or LP gas will result in extremely dangerous burner operation, leading to fire, explosion, severe injury or death.

**⚠ WARNING**

Strain on the gas valve and fittings may result in vibration, premature component failure and gas leakage, and result in fire, explosion, property damage, severe personal injury, or death.

**⚠ WARNING**

Adjustments to the throttle screw or offset may only be made by a qualified gas technician using a calibrated combustion analyzer capable of measuring CO<sub>2</sub> and CO. Failure to follow this instruction could result in fire, explosion, property damage, severe personal injury, or death.

**⚠ WARNING**

Do not do a gas conversion on this unit without an officially approved conversion kit and instructions supplied by HTP. Failure to do so could result in serious injury or death.

**E. HOW TO VERIFY COMBUSTION**

To activate service mode, press the up arrow ▲ and ENTER key together for 1 second. The unit will go through the ignition sequence. Press ▲ to increase, or ▼ to decrease fan speed.

SERVICE RUN 3400 RPM  
PUMP ON 4:49P

To leave service mode, press ▲ and ▼ simultaneously.

**COMBUSTION SETTINGS ON ALL MODELS**

Fan Speed	Natural Gas			Propane LP		
	Low	Ignition	High	Low	Ignition	High
Carbon Monoxide PPM	1 – 10	2 - 15	2 – 20	1 – 10	2 - 15	2 – 20
Carbon Dioxide (CO <sub>2</sub> )	8 - 10%	8 – 10%	8 - 10%	8 ½ - 10 ½%	8 ½ - 10 ½%	9 - 11%

Table 10

**FAN SPEEDS**

BTU	IGNITION	MIN	MAX
130,000	3000	2000	7300
199,000	3000	2000	9100

Table 11

**PART 9 - START-UP PROCEDURE**

**⚠ WARNING**

**FOR YOUR OWN SAFETY READ BEFORE OPERATING**

1. This appliance does not have pilot. It is equipped with an ignition device which automatically lights the burner. Do not try to light the burner by hand.
2. BEFORE OPERATING: smell all around the appliance area for gas. Be sure to smell next to the floor because some gas is heavier than air and will settle on the floor.

**WHAT TO DO IF YOU SMELL GAS**

- Do not try to light any appliance.
- Do not touch any electric switch; do not use any phone in your building.
- Immediately call your gas supplier from a neighbor's phone. Follow the gas suppliers' instructions.
- If you cannot reach your gas supplier, call the fire department.
- Turn off gas shutoff valve (located outside of the appliance) so that the handle is crosswise to the gas pipe. If the handle will not turn by hand, don't try to force or repair it, call a qualified service technician. Force or attempted repair may result in a fire or explosion.

4. Do not use this appliance if any part has been under water. Immediately call a qualified service technician to inspect the appliance and to replace any part of the control system and any gas control that has been damaged.

5. The appliance shall be installed so the gas ignition system components are protected from water (dripping, spraying, rain, etc.) during appliance operation and service (circulator replacement, condensate trap, control replacement, etc.)

Failure to follow these instructions could result in property damage, serious personal injury, or death.

**A. FILL AND PURGE DHW**

**⚠ WARNING**

Ensure the appliance is full of water before firing the burner. Failure to do so will damage the appliance. Such damage IS NOT covered by warranty, and could result in property damage, serious personal injury, or death.



The power must remain off until the potable water side of the appliance is fully purged of air. To purge the tank, turn on the cold water feed and open a faucet at the highest point of the system. Observe filling of the tank and inspect for any leaks in the system which may occur and need to be repaired. Shut off faucet once all evidence of air is purged from the water stream.

## **B. FILL AND PURGE HYDRONIC HEATING LOOP**

### **Freeze Protection (When Used)**

#### **⚠ WARNING**

Never use automotive or standard glycol antifreeze, or ethylene glycol made for hydronic systems. Use only freeze-prevention fluids certified by fluid manufacturer as specified for use with stainless steel hydronic heating module heat exchanger and verified in fluid manufacturer's literature.

Thoroughly clean and flush any system that has used glycol before connecting to the stainless steel hydronic heating module heat exchanger. Provide MSDS material data safety sheet on fluid used to owner.

1. Local codes may require back flow preventer or actual disconnect from city water supply.
2. The power must remain off until the hydronic heating loop is fully purged of air.
3. Determine freeze protection fluid quantity using total system water content of 1/2 gallon. Remember to include expansion tank water content and follow fluid manufacturer's instructions.
4. When using freeze protection fluid with automatic fill, install a water meter to monitor water make-up. Freeze protection fluid may leak before the water begins to leak, causing concentration to drop, reducing the freeze protection level.
5. Close manual any automatic air vents and any drain valves in the hydronic system loop.
6. Fill the system to correct pressure after ensuring the water quality meets the water quality standards outlined within this manual (See Part 3, Section H). The correct pressure will vary with each application.
  - a. Typical system pressure is 15 PSI.
  - b. Pressure will rise when the hydronic module starts to heat from the heated water from the domestic side of the system. Operating pressure must never exceed the relief valve pressure setting of 30 psi.
  - c. At initial fill and during start-up and testing, check system thoroughly for any leaks. Repair all leaks before proceeding further.

#### **CAUTION**

Eliminate all system leaks. Continual fresh make-up water will reduce the hydronic heating module heat exchanger ability to effectively transfer heat and reduce performance.

7. The system may have residual substances that could affect water chemistry. After the system has been filled and leak tested, verify that water pH and chlorine concentrations are acceptable by sample testing.

#### **CAUTION**

It is important that you purge the system of air to avoid damage to the modulating pump.

## **C. PURGE AIR FROM HYDRONIC HEATING MODULE**

- a. Connect to a purge and drain valve location (shown in piping details) and route hose to an area where water can drain and be seen.
- b. Close the ball valves below the purge and drain valve.
- c. Close zone isolation valves.
- d. Open quick-fill valve on make-up water line.
- e. Open purge valve.
- f. Open the isolation valves one zone at a time. Allow water to run through the zone and push out air. Run until no noticeable air flow is present. Close the zone isolation valves and proceed with the next zone. Follow this procedure until all zones are purged.
- g. Close the quick-fill valve and purge valve and remove the hose. Open all isolation valves. Watch the system pressure rise to correct cold-fill pressure. It is recommended that you put the pumps into manual operation to assist in purging the circuits.

### **D. APPLIANCE PUMP CONTROL TO ASSIST IN PURGING AIR FROM SYSTEM LOOPS**

Before powering up the control assure the thermostat connection is disconnected on the field connection board. Apply power to the appliance (Note: The appliance will fire the burner and heat the water inside the storage tank to the domestic hot water temperature set point). Press ►. The display can show the temperature set point of the appliance. Press the ▼ and **ENTER** keys simultaneously and hold for 1 second. The display will read:

```
SERVICE PUMP      CH
PUMP ON           TIME
```

The central heating pump will come on. Run pump until all the air has been purged through each circuit. If you press the ▼▲ keys simultaneously, the central heating pump will shut off. The display will read:

```
READY
PUMP OFF          12:42
```

Once the system has been purged of air, the installer can now proceed to program the control and system design parameters.

### **E. PROGRAMMING THE TOTAL SYSTEM CONTROL**

Before programming the Total System Control to the specific needs of the system, verify that the system is ready for operation. Be certain that:

- The Domestic Hot Water system is filled with water that meets the qualifications and all air is purged.
- The mixing valve supplied is properly installed.
- The Hydronic Heating System is filled with water and meets all qualifications and all air is purged.
- The outdoor reset sensor is installed in a proper location.
- The electrical power supply is installed by a licensed professional.
- Turn down thermostats, making sure that they are set so there is no call for heat while programming.

**This section discusses how to program a few of the major sections of the control parameters for optimum system performance. See the control overview section for more detailed information on the operation of the display and other parameters.**

1. Turn on the main power switch on the top right of the burner cabinet. NOTE: At first startup, the water in the tank is cold and the burner will ignite. This is normal operation. You can continue to adjust settings while the burner is running.

2. Press and hold **ENTER** for 4 seconds until you see the screen to enter the log in access code shown below.

3. Use the ◀ key to move the blinking zero to the left most zero. Next, use ▲ and ▼ to log in 600, the access code. Press **ENTER** confirm the code and access Appliance Setting Program Navigation menu.

```
ENTER MENU CODE
000
```

4. Once the code is confirmed, you can begin to set the Appliance Settings. Use the arrow keys to navigate. To change a setting, press **ENTER**. Appliance settings can be increased by pressing ▲ and decreased by pressing ▼ on the display. Once a new value has been selected, press **ENTER** to store the new value.

```
CENTRAL HEATING
140°F
```

5. The first screen is the “Central Heating” value. Enter the value for your designed hydronic heating supply temperature. The factory default is 140°F. NOTE: Values are determined based on program settings.

```
HEATING DELTA T
20°F
```

6. After you have entered and stored the “Central Heating” value, press ► once. The second screen adjusts the heating system “Heating Delta T” value. The factory default is 20°F.

7. After you have entered and stored the “Heating Delta T” value, press ► once. The third screen adjusts the “DHW Set Point”. Adjust the value to the desired Domestic Hot Water temperature. The factory default is 119°F. **IMPORTANT NOTE:** This value sets the tank temperature when the appliance is in warm weather shutdown. A mixing valve must be properly installed and adjusted to a proper outlet value for safe operation.

```
DHW SETPOINT
119°F
```

8. After you have entered and stored the “DHW Set Point” value, press **RESET** to return to the home screen on the display. This completes the essential programming in Appliance Setting Programs. If other values need to be changed in this section, such as the display time, refer to Control Overview, Part 10.

9. A proper outdoor reset curve should be set to further optimize system performance and efficiency. Figure 28 shows how each function will affect system performance. The values in Figure 28 show the system default.

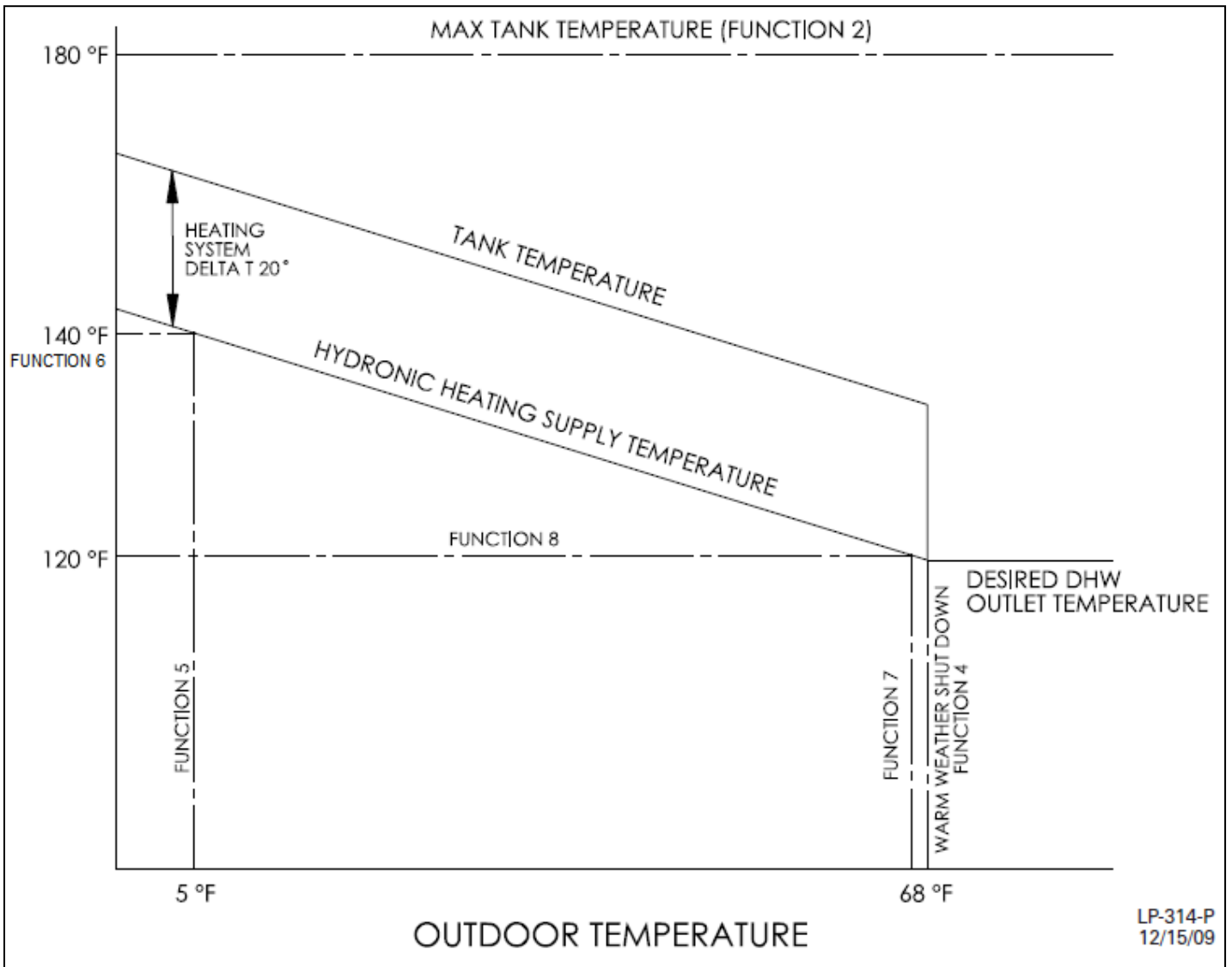


Figure 28

10. Press and hold **ENTER** for 4 seconds until you see the screen to log in the access code.

11. Use the ◀ and ▶ arrow keys to move the blinking zero to the left and right. Next, use the ▲ and ▼ arrow keys to log in the access code of 925. Press **ENTER** to access the **System Setting Program Navigation** menu. Once the code is confirmed, you can set the **System Settings**. Use ◀ and ▶ to navigate through the **System Setting Program**.

```
ENTER MENU CODE
000
```

12. Press ▶ 3 times to scroll to Function 4 - "WARM WEATHER OFF". This is the warm weather shutdown. This function determines the outdoor temperature that will turn off the hydronic heating module and operate the appliance only as an appliance for the warmer weather. To adjust this value, press **ENTER** and the factory default of 68°F starts to blink. Use ▲ and ▼ to adjust this value to your system needs. To store the new value press **ENTER**.

13. Next, press ▶ once to scroll to Function 5 - "MIN OUTDOOR TEMP". This function is the first step to setting the outdoor reset curve. Enter your system's minimum outdoor temperature value. To adjust the value, press **ENTER** and the factory default of 5 °F starts to blink. Use ▲ and ▼ to adjust to your designed temperature. To store the new value press **ENTER**.

14. Press ▶ once to scroll to Function 6 - "MAX SUPPLY TEMP". This function is the second step to setting your outdoor reset curve. Enter your system's hydronic heating module maximum supply temperature value. To adjust the value, press **ENTER** and the factory default of 140 °F will start to blink. Use ▲ and ▼ to adjust to your designed temperature. To store the new value press **ENTER**. NOTE: This should be the same value entered in step 5.

15. Press **▶** once to scroll to Function 7 - "MAX OUTDOOR TEMP". This function is the third step to setting your outdoor reset curve. Enter your system's maximum outdoor temperature value. To adjust the value, press **ENTER** and the factory default of 68 °F will start to blink. Use **▲** and **▼** to adjust to your designed temperature. To store the new value press **ENTER**.

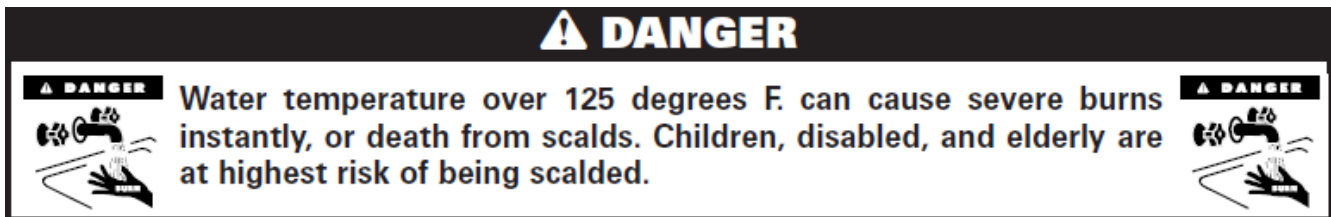
16. Press **▶** once to scroll to Function 8 - "MIN SUPPLY TEMP". This function is the final step to setting your outdoor reset curve. Enter your system's hydronic heating module minimum supply temperature value. To adjust the value, press **ENTER** and the factory default of 120 °F will start to blink. Use **▲** and **▼** to adjust to your designed temperature. To store the new value press **ENTER**.

17. The major Total System Control values are now programmed. Press **RESET** to return to the main screen. To adjust other system values, refer to Control Overview, Part 10.

18. Insure that there is no air lock or blockage in the tank side loop of the hydronic heating module. To do this, press and hold **▼** and **ENTER**. This will bring you into the pump service mode. Press **▲** 3 times until "SERVICE PUMP RS 5" is on the screen. This puts the hydronic heating module pump at 5 volts (50%). Press **▶** until the value is increased to 10, putting the pump at full speed. Once flow is confirmed, press **▲** and **▼** at the same time to return you to the main screen.

19. Allow the temperature in the tank to reach its value. Once the tank is up to temperature the burner will shut off.

20. Once the temperature in the tank is up to its set point, the DHW mixing valve must be set correctly. Turn on the hot water faucet at a nearby source. Use a temperature measuring device to measure the water temperature. **DO NOT USE YOUR HANDS!** Any skin contact at this point could cause serious injury. Adjust mixing valve to desired hot water outlet following Mixing Valve Instructions in Part 4, Section E.



21. Once a safe DHW outlet temperature is set with the supplied mixing valve, the system is ready to run. Adjust thermostats to the desired value. Total System Control will now modulate and control the system.

## PART 10 - CONTROL OVERVIEW

The control monitors the safety sensors of the appliance to assure safe and efficient operation. It has many features to address configurations associated with hydronic design.

This section addresses the programming features of the control. It is important to fully understand its capabilities. This section addresses the adjustment of Appliance Settings / System Settings / Maintenance Settings and System Diagnostics to help customize your control. However, the control is programmed with factory defaults that may already fit your hydronic design and may not require any adjustment at all.

### A. NAVIGATION OF THE DISPLAY

The display includes a two-line backlit LCD readout that provides informative messages about appliance operation. Many operating parameters can be viewed and adjusted by using the six buttons on the display. The function of each button is described below.

**RESET** – The RESET button has two functions:

- Reset any lockout error code.
- Return the user to the default display screen.

ENTER MENU CODE 000
------------------------

**ENTER** – The ENTER key is used to enter the parameter programming mode. To enter this mode, hold down the ENTER key for more than 4 seconds. The readout will change to:

One of the zeroes will be blinking. Use the **▲▼** arrow keys to change the blinking digit to the correct value. Use the **◀▶** arrow keys to select the next digit to change and again use the **▲▼** keys to change the value. Repeat until the correct code is entered. Press the **ENTER** key to accept the code. If the code is correct, the readout will change to the appropriate screen. If the programming code is not accepted the readout will continue to display as shown above.

The **ENTER** key is also used to enable a parameter for editing. After navigating to the desired parameter, hold down the **ENTER** key for one second. When the **ENTER** key is released, the parameter value will begin to blink. The parameter can now be changed using the **▲▼** keys. After the new value is selected, presses the **ENTER** key for 1 second to lock in the new parameter value. The value will then stop blinking.

**ARROW** Keys – The right and left arrow keys (◀▶) are used to navigate between the default Display and Status Display. The ◀▶ keys are also used in programming modes to change between programmable parameters. It is recommended you use the Menu Maps in the back of this manual and the detailed menu instructions printed in this section to help in menu navigation.

**ARROW** Keys – The up and down (▲▼) arrow keys are used to navigate between the various parameters displayed in the menu. After the parameter is enabled for editing by pushing the **ENTER** key, the ▲▼ keys are used to adjust the parameter upward or downward to the desired value.

## **B. PROGRAMMING THE CONTROL**

### **Program Access**

Note: Programming the control is not possible when the appliance is firing. Make sure any input (such as the thermostat) is turned off, so the appliance will remain idle and allow programming.

<b>SCREEN</b>	<b>DESCRIPTION</b>
ENTER MENU CODE 000	To access the appliance setting program, press and hold the <b>ENTER</b> Key for 4 seconds, until the display shows the screen at left.
ENTER MENU CODE 600	Using the arrow keys, log in <b>Access Code "600"</b> . To confirm the code, press <b>ENTER</b> to access <b>Program</b> navigation menu.

**Table 12 – Accessing the Control**

## **C. APPLIANCE SETTING PROGRAM NAVIGATION MENU**

Once the code is confirmed, the user can now start to set the **Appliance Settings**. Use the arrow keys on the display to navigate through the **Appliance Setting Program**. To change a setting, press **ENTER**. Appliance settings can be increased by pressing ▲ and decreased by pressing ▼ on the display. Listed below are the appliance settings that can be programmed into the control. The first three are the most important to program correctly in order for the total system control to operate the appliance at optimum efficiency.

<b>SCREEN</b>	<b>DESCRIPTION</b>
CENTRAL HEATING 140 °F	<b>Function:</b> Adjusts the central heating designed supply set point. Default: 140°F (Range: 50°F to 170°F).
HEATING DELTA T 20 °F	<b>Function:</b> Adjusts the heating system designed delta T set point. Default: 20°F (Range: 5°F to 30°F).
DHW SET POINT 119 °F	<b>Function:</b> Allows the user to adjust the DHW set point from 95°F to 180°F (Factory default 119°F). NOTE: The appliance is supplied with a thermostatic mixing valve that must be installed on to the domestic hot water system. Any changes in this set point will also require adjustment to the mixing valve. Please refer to the mixing valve section in Domestic Water Piping, Part 4, for further setup and operation details.
BURNER RUN OFFSET 5 °F	<b>Function:</b> Allows the user to adjust the degree offset from the current target tank temperature where the burner will ignite 1°F to 18°F (Factory default 5°F).
TEMP DISPLAY C OR F °F	<b>Function:</b> Adjusts the temperature measurement in F = Fahrenheit to C = Celsius (Default is Fahrenheit).

**Table 13 – Appliance Settings**

### **Clock Settings**

(Note: The clock will reset if the appliance is powered off for more than a week.)

<b>SCREEN</b>	<b>DESCRIPTION</b>
CLOCK MODE (12/24) 08/28/2009 Fr 9:42A	<b>Function:</b> Changes the clock from 12 hour mode (8:45 PM) to 24 hour mode (20:45). To change to 24 hour mode, press the <b>ENTER</b> key. The letter (A or P) after the time will blink. Press the up or down arrow key once and the letter will disappear. Press the <b>ENTER</b> key to save the new setting.
CLOCK HOUR 08/28/2009 Fr 10:01A	<b>Function:</b> Allows the user to adjust the hour setting.
CLOCK MINUTE 08/28/2009 Fr 10:01A	<b>Function:</b> Adjusts the minute setting.
CLOCK DAY OF WEEK 08/28/2009 Fr 10:01A	<b>Function:</b> Adjusts the day of week.
CLOCK DATE MODE 08/28/2009 Fr 10:01A	<b>Function:</b> Allows the user to switch to European date format (2009/08/28) from US format (08/28/2009).

CLOCK YEAR 08/28/2009 Fr 10:01A	<b>Function:</b> Adjusts the year setting.
CLOCK MONTH 08/28/2009 Fr 10:01A	<b>Function:</b> Adjusts the month setting.
CLOCK DATE 08/28/2009 Fr 10:01A	The clock is set.

**Table 14 – Clock Settings**

**NOTE:** The clock does not automatically adjust for Daylight Savings Time, and requires manual adjustment.

#### **D. PROGRAMMING THE SYSTEM SETTING**

**NOTE:** Programming the control is not possible when the unit is firing. Make sure any input (such as the thermostat) is turned off, so the appliance will remain idle to allow programming.

SCREEN	DESCRIPTION
ENTER MENU CODE 000	To access the system setting program, press and hold the <b>ENTER</b> Key for 4 seconds, until the display shows the screen at left.
ENTER MENU CODE 925	Using the arrow keys on the display, log in your <b>System Menu Access Code “925”</b> . To confirm code, press <b>ENTER</b> to access system setting program navigation menu.

**Table 15 – System Settings**

#### **E. SYSTEM SETTING PROGRAM NAVIGATION**

Once the **System Menu Access Code** is confirmed, the user can start to set the System Parameters Menu. Use the arrow keys on the display to navigate through the different program settings. To change an appliance setting, press **ENTER**. Increase system settings by pressing **▲** and decrease by pressing **▼** on the display.

Listed below are the system settings that can be programmed into the control.

SCREEN	DESCRIPTION
<b>Function 1</b>	<b>Factory Program Mode</b>
MODE 1 PHOENIX	This screen indicates that the control is configured correctly. Do not change this setting.
<b>Function 2</b>	<b>Max Tank Temp</b>
MAX TANK TEMP 2 180 °F	Sets the overall tank temperature maximum limit. Factory default 180°F (Range 95°F to 185°F).
<b>Function 3</b>	<b>DHW Offset Temp</b>
OFFSET 3 0°F	Not Used.
<b>Function 4</b>	<b>Warm Weather Shutoff</b>
WARM WEATHER OFF 4 68 °F	Warm Weather Shutoff disables the heating module and the Total System Control will then optimize for domestic hot water only. Warm Weather Shutoff will occur if the programmed outdoor temperature is exceeded by the current outdoor sensor temperature. Factory default 68°F (Range 41°F to 122°F).
<b>Function 5</b>	<b>Min Outdoor Temp</b>
MIN OUTDOOR TEMP 5 5 °F	Allows the user to set the minimum outdoor design temperature for the system. Factory default 5°F (Range -49°F to 122°F).
<b>Function 6</b>	<b>Max Supply Temp</b>
MAX SUPPLY TEMP 6 140 °F	Allows the user to set the maximum design supply temperature based on the minimum outdoor design temperature. Factory default 140°F (Range 77°F to 170°F).
<b>Function 7</b>	<b>Max Outdoor Temp</b>
MAX OUTDOOR TEMP 7 68 °F	Allows the user to set the maximum outdoor design temperature for the system. Factory default 68°F (Range 32°F to 95°F).
<b>Function 8</b>	<b>Min Supply Temp</b>
MIN SUPPLY TEMP 8 120 °F	Allows the user to set the design supply water temperature based on the maximum outdoor design temperature. Factory default 120°F (Range 32°F to 200°F).
<b>Function 9</b>	<b>Min Tank Temp</b>
MIN TANK TEMP 9 68 °F	Allows the user to set the minimum tank temperature. Factory default 68°F (Range 32°F to 200°F).
<b>Function 10</b>	<b>CH Post Pump Time</b>
CH POST PUMP TIME 10 0 MINUTES	Allows the user to set the central heating pump post purge time once the thermostat is satisfied. Factory default 0 minutes (Range 0 to 10 minutes).

<b>Function 11</b>	<b>DHW Priority</b>
DHW PRIORITY 11 30 MINUTES	Allows the user to set DHW priority time, which is the amount of time to shut down the hydronic heating module when the system control senses a large domestic hot water usage. Factory default 30 minutes (Range 0 to 60 minutes).
<b>Function 12</b>	<b>Error Outdoor Sensor</b>
ERROR OUTD SENSOR 12 ON	Allows the user to set the control to display an error message if an outdoor sensor is open or shorted. NOTE: This error does not stop the appliance from running. Factory default ON (Selection ON/OFF/PHOEN ON).
<b>Function 13</b>	<b>Error System Sensor</b>
ERROR SYSTEM SENS 13 ON	Allows the user to set the control to display an error message if the system sensor is open or shorted. NOTE: This error does not stop the appliance from running. Factory default ON (Selection ON/OFF).
<b>NOTE: Press ENTER to store system parameters.</b>	
<b>Function 14</b>	<b>Service Schedule</b>
SERVICE SCHEDULE 14 OFF	Allows the user to program the appliance maintenance schedule by selecting a service date or time based on the appliance run hours. Factory default OFF (Selection - Date or Run Hours). NOTE: Without setting this function, Functions 33 through 36 will not display.
<b>Function 15</b>	<b>Year</b>
SERVICE SCHEDULE 15 YEAR 00/00/2000	This parameter sets the year of the next service reminder.
<b>Function 15</b>	<b>Hours</b>
SERVICE SCHEDULE 15 10000's 000000h	This parameter sets the 2 left digits of the amount of run hours until the next service reminder. If you selected the run hour function, you will need to program 10,000 hours.
<b>Function 16</b>	<b>Month</b>
SERVICE SCHEDULE 16 MONTH 00/00/2000	If you selected the date function, you will need to program the month.
<b>Function 16</b>	<b>Hours</b>
SERVICE SCHEDULE 16 10000's 000000h	This parameter sets the 2 middle digits of the amount of run hours until the next service reminder.
<b>Function 17</b>	<b>Day</b>
SERVICE SCHEDULE 17 DAY 00/00/2000	Sets the day in the date function.
<b>Function 17</b>	<b>Hours</b>
SERVICE SCHEDULE 17 10000's 000000h	Sets the 2 right digits of the amount of run hours until the next service reminder.
<b>Function 18</b>	<b>Telephone Number</b>
TELEPHONE # 18 000 000 0000	Allows the user to input a telephone number that will be displayed when maintenance is required.
<b>Function 37</b>	<b>Modbus Mode</b>
MODBUS MODE OFF 37	Enables Modbus Mode on the appliance. Factory Default: OFF (Range: OFF, ON, AUTO). <b>NOTE:</b> Turning Modbus Mode "ON" will open a number of additional parameters to customize Modbus installation. See Modbus Instructions (lp-372) for details. <b>NOTE:</b> Turning this Mode "ON" without a connected and powered Modbus communication adapter (p/n 7350P-629) will result in improper appliance operation. Service calls associated with this ARE NOT covered by warranty.
<b>Function 52</b>	<b>Solar Mode (Available on Solar Appliances ONLY)</b>
SOLAR MODE ON 52	When turned ON, this parameter enables solar function of the control. Default: OFF. <b>NOTE:</b> Turning Solar Mode "ON" will open a number of additional parameters to customize the solar installation. See Solar Kit Instructions (lp-420) for details. <b>NOTE:</b> Turning this Mode "ON" without a connected Solar Kit (p/n 7100P-220) will result in improper appliance operation. Service calls associated with this ARE NOT covered by warranty.

**Table 16 – System Setting Program Navigation**

### **F. CONTROL STATUS MENU**

The controller also has the ability to review the status of the system. To access the status screens, press the ► key. Once the first value is displayed, press the ▲ or ▼ keys to access additional information. At any point you may press **RESET** to exit the Status screen.

SCREEN	DESCRIPTION
TOP TANK 160°F BOT TANK 123°F	This screen displays the actual temperature that the top and bottom tank sensors are measuring.
Press the ▼ key once.	
CH TARGET 140°F CH SUPPLY 122°F	This screen displays the current central heating temperature set point on the top line. <b>NOTE:</b> If an outdoor sensor is used, this temperature set point may vary from what was set in the Appliance Settings Screen. The bottom line is the actual temperature measured by the hydronic heating module supply sensor.
Press the ▼ key once.	
CH DEMAND OFF OUTDOOR 55°F	The top line of this screen displays the current status of the central heating demand. The bottom line displays the temperature measured by the outdoor sensor (when used). If there is no outdoor sensor connected to the appliance, the display will read "OFF". If the contacts are jumped, this line will display "ON" in place of the temperature.

	<b>NOTE:</b> To ensure a properly installed sensor, be sure that this temperature reading is similar to the current outdoor conditions.
Press the ▼ key once.	
DHW SETING 119°F TANK TARGET 160°F	The top line of this screen displays the current domestic hot water temperature set point entered in the Appliance Settings. The bottom line displays the current tank target temperature. <b>NOTE:</b> This target tank temperature set point will vary due to the total system control that is based on environment and system conditions.
Press the ▼ key once.	
FLAME 0.0uA FAN SPEED 3497 RPM	The top line displays the appliance flame current. The bottom line displays appliance fan speed.
Press the ▼ key once.	
POWER ON 0h INPUT 0kBTU	The top line indicates the amount of hours the appliance has power applied to its lifetime. The bottom line indicates how much energy input (in thousand BTU) from the burner into the storage tank.
Press the ▼ key once.	
DHW USE 0% CH USE 1%	The top line of this display indicates the percentage of energy used for domestic hot water over the appliance lifetime. The bottom line indicates the percentage of energy used for central heating over the appliance lifetime.
Press the ▼ key once.	
GOOD IGNIT 0x CH CYCLE 0x	The top line of this display indicates the number of times the burner has turned on over the appliance lifetime. The bottom line indicates the number of times the heating module has cycled for central heating demand.
Press the ▼ key once.	
FAULT HISTORY 1 07/27/2009 Mo 5:19A	This screen displays the last lockout fault of the appliance control. The top line will alternate between the words "FAULT HISTORY" and the fault encountered. The bottom line will display the date and time the fault occurred.
Press the ▼ key once.	
FAULT HISTORY 2 08/28/2009 Fr 5:19A	This screen displays the second oldest lockout fault of the appliance control. The top line will alternate between the words "FAULT HISTORY" and the fault encountered. The bottom line will display the date and time the fault occurred.
Press the ▼ key once.	
FAULT HISTORY 3 08/28/2009 Fr 5:19A	This screen displays the third oldest lockout fault of the appliance control. The top line will alternate between the words "FAULT HISTORY" and the fault encountered. The bottom line will display the date and time the fault occurred.
Press the ▼ key once.	
FAULT HISTORY 4 08/28/2009 5:19A	This screen displays the fourth oldest lockout fault of the appliance control. The top line will alternate between the words "FAULT HISTORY" and the fault encountered. The bottom line will display the date and time the fault occurred.
Press the ▼ key once.	
FAULT HISTORY 5 08/28/2009 5:19A	This screen displays the fifth oldest lockout fault of the appliance control. The top line will alternate between the words "FAULT HISTORY" and the fault encountered. The bottom line will display the date and time the fault occurred.
Press the ▼ key once.	
FAULT HISTORY 6 08/28/2009 5:19A	This screen displays the sixth oldest lockout fault of the appliance control. The top line will alternate between the words "FAULT HISTORY" and the fault encountered. The bottom line will display the date and time the fault occurred.
Press the ▼ key once.	
FAULT HISTORY 7 08/28/2009 5:19A	This screen displays the seventh oldest lockout fault of the appliance control. The top line will alternate between the words "FAULT HISTORY" and the fault encountered. The bottom line will display the date and time the fault occurred.
Press the ▼ key once.	
FAULT HISTORY 8 08/28/2009 5:19A	This screen displays the eighth oldest lockout fault of the appliance control. The top line will alternate between the words "FAULT HISTORY" and the fault encountered. The bottom line will display the date and time the fault occurred.
Press the ▼ key once.	
FAULT HISTORY 9 08/28/2009 5:19A	This screen displays the ninth oldest lockout fault of the appliance control. The top line will alternate between the words "FAULT HISTORY" and the fault encountered. The bottom line will display the date and time the fault occurred.
Press the ▼ key once.	
FAULT HISTORY 10 08/28/2009 10:01A	This screen displays the tenth oldest lockout fault of the appliance control. The top line will alternate between the words "FAULT HISTORY" and the fault encountered. The bottom line will display the date and time the fault occurred.

**Table 17 – Control Status Menu**

### **G. RESETTING THE MAINTENANCE SCHEDULE**

When the system control flashes MAINTENANCE REQUIRED, it is advisable that you call for service. After the service is performed, reset the schedule for the next required service by using the following steps.

Press **ENTER** on the display for 3 seconds. The Menu code will appear as 000. This does not change. Press **ENTER** again. SERVICE SCHEDULE RESET will be displayed. Using the right arrow key ► scroll to the selection of year or hours. Select enter to reset the mode you are in. Use the up ▲ or down ▼ arrow key for each adjustment then select **ENTER** when reset is complete.



## PART 11 - SHUTDOWN

### A. SHUTDOWN PROCEDURE

If the burner is operating, lower the set point value to 70°F and wait for the burner to shut off. Then, wait for the combustion blower to stop so all latent combustion gases are purged from the system. This should take 40 to 90 seconds. After the combustion blower and burner have stopped operating, disconnect the electrical supply.

### B. VACATION PROCEDURE

If there is danger of freezing, change the set point to 70°F. **DO NOT turn off electrical power!** If there is no danger of freezing, follow Shutdown Procedure, Part 11, Section A.

### C. FAILURE TO OPERATE

Should the burner fail to light, the control will perform two more ignition trials prior to entering a lockout state. Note that each subsequent ignition trial will not occur immediately. After a failed ignition trial, the blower must run for approximately 10 seconds to purge the system. Therefore, a time period of approximately 40 to 90 seconds will expire between each ignition trial. If the burner lights during any one of these three ignition trials, normal operation will resume. If the burner lights, and goes off in about 4 seconds, check the polarity of the wiring. See Electrical Connection Section in Part 7.

If the burner does not light after the third ignition trial, the control will enter a lockout state. This lockout indicates that a problem exists with the appliance, the controls, or the gas supply. Under such circumstances, a qualified service technician should be contacted immediately to properly service the appliance and correct the problem. If a technician is not available, pressing **RESET** once will remove the lockout state so additional trials for ignition can be performed.

## PART 12 - TROUBLESHOOTING

### A. APPLIANCE ERROR CODE

If any of the sensors detect an abnormal condition or an internal component fails during the operation of the appliance, the display may show an error message and error code. This message and code may be the result of a temporary condition, in which case the display will revert to its normal readout when the condition is corrected.

However, it may also be the result of a condition that the controller has evaluated as not safe to restart the appliance. In this case, the appliance control will be locked out, the red FAULT light will be lit steadily, and the message "LOCKOUT" will be displayed on the readout on the lower line. The appliance will not start until a qualified technician has repaired the fault and pressed the **RESET** button for more than 1 second. If there is an error message displayed on the readout and the message "LOCKOUT" is not displayed and the FAULT light is not lit, then the message is the result of a temporary condition and will disappear when the problem corrects itself.

**IMPORTANT NOTE:** If you see error messages on your display readout, call a technician immediately since the message may indicate that more serious problems will occur soon.

### B. APPLIANCE ERROR

When an error condition occurs, the controller will display a description and code on the display readout. These error messages and their recommended corrective actions are described in Section D, Appliance Control Fault Codes.

### C. APPLIANCE FAULT

1. When a fault condition occurs, the controller will illuminate the red FAULT light and display a fault message in the display. The alarm output will also be activated. Most fault conditions also cause the CH pump to run in an attempt to cool the appliance.
2. Note the fault message that is displayed and refer to the Fault Code section for an explanation of the fault message, along with several suggestions for corrective actions.
3. Press **RESET** to clear the fault and resume operation. Be sure to observe the operation of the unit for a period of time to assure correct operation and no recurrence of the fault message.

### D. APPLIANCE CONTROL FAULT CODES

#### **WARNING**

When servicing or replacing any components of this appliance, be certain that:

- The gas is off.
- All electrical power is disconnected.

**⚠ DANGER**

When servicing or replacing components that are in direct contact with this appliance, be certain that:

- There is no pressure in the appliance. (Pull the release on the relief valve to relieve pressure.)
- Appliance water is not hot.
- Electrical power is disconnected.

**⚠ WARNING**

**DO NOT USE THIS APPLIANCE IF ANY PART HAS BEEN SUBMERGED IN WATER.** Immediately call a qualified service technician. The appliance **MUST BE** replaced if it has been submerged. Attempting to operate an appliance that has been submerged could create numerous harmful conditions, such as a potential gas leakage causing a fire and/or explosion, or the release of mold, bacteria, or other harmful particulates into the air. Operating a previously submerged appliance could result in property damage, severe personal injury, or death.

**NOTE:** Appliance damage due to flood or submersion is considered an Act of God, and IS NOT covered under product warranty.

**⚠ CAUTION**

This appliance has wire function labels on all internal wiring. Observe the position of each wire before removing it. Wiring errors may cause improper and dangerous operation. Verify proper operation after servicing.

Outdoor Sensor (7250P-319)		Temperature Sensors	
Outside Temperature (°F)	Resistance (ohms)	UPPER SENSOR 7100P-004 / LOWER SENSOR 7100P-005 / CLIP ON SENSOR 7100P-172	
		Water Temperature (°F)	Resistance (ohms)
-22	171800	32	32550
-13	129800	41	25340
-4	98930	50	19870
5	76020	59	15700
14	58880	68	12490
23	45950	77	10000
32	36130	86	8059
41	28600	95	6535
50	22800	104	5330
59	18300	113	4372
68	14770	122	3605
77	12000	131	2989
86	9804	140	2490
95	8054	149	2084
104	6652	158	1753
113	5522	167	1481
		176	1256
		185	1070
		194	915
		203	786
		212	667

**Table 18 – Resistance Tables**

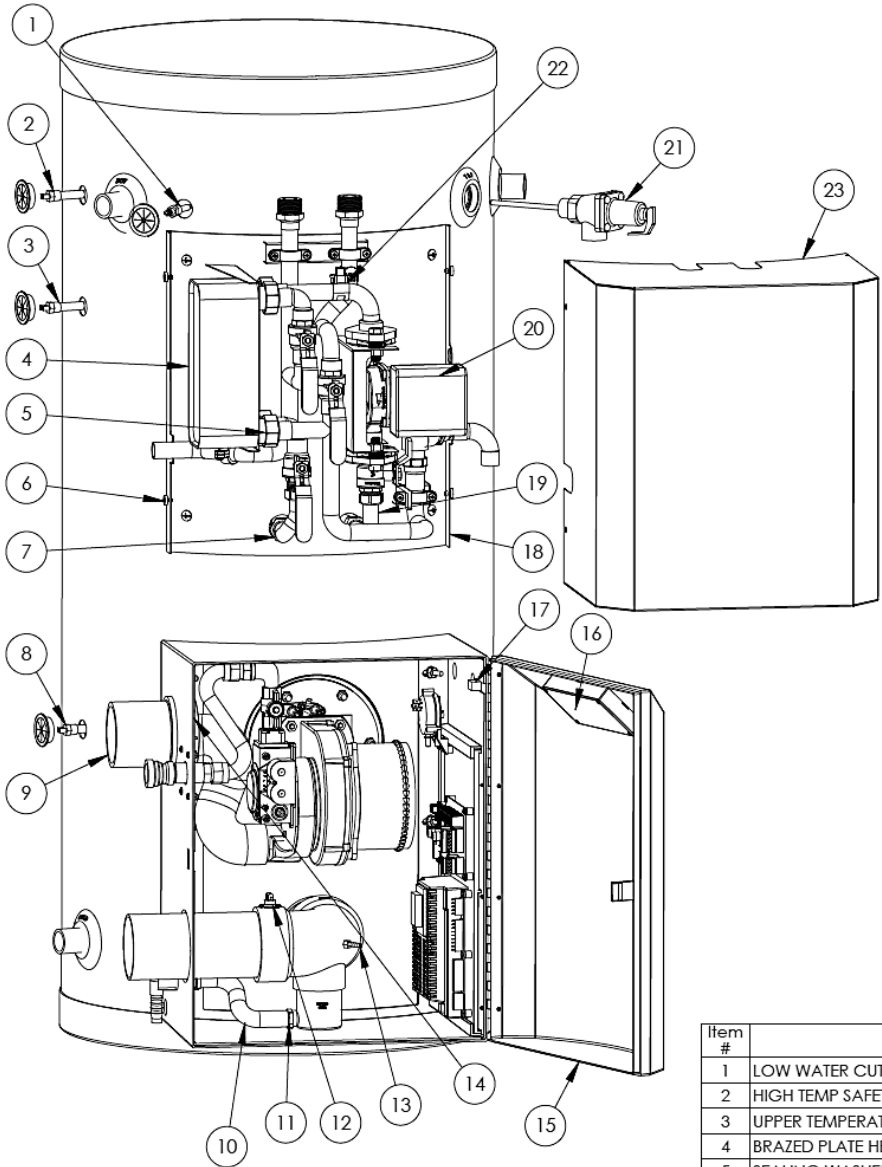
SCREEN	DESCRIPTION	POSSIBLE REMEDY
<b>Fault Code FOU Outdoor Sensor Failure</b>		
OUTDOOR SENSOR FOU PUMP ON	This indicates that the outdoor sensor is defective, shorted or open, or the outdoor temperature is below -40°F. <b>NOTE:</b> The installer must choose YES in Function 12 to enable this feature. The unit will continue to operate when this error is displayed but the control will ignore the outdoor reset feature and run at the programmed temperature. The bottom line indicates the status of the pump.	Inspect wiring from outside sensor for damage or shorted connections and repair as necessary. Measure resistance of outdoor sensor and compare to resistance chart. If not within range on chart, shorted or open, replace sensor.

<b>Fault Code E07 CH Sensor Failure</b>		
CH SENSOR FAIL PUMP ON	This indicates that one or both of the clip-on temperature sensors in the hydronic heating module has been disconnected. This error allows the tank portion of the unit to operate, but will not allow the hydronic heating module to operate until the error is cleared. The error will clear if proper sensor connection is restored. The bottom line indicates the status of the pump.	<ol style="list-style-type: none"> <li>1. Go to the STATUS menu screen that displays "CH Supply" on the bottom line. This will help to determine which sensor has the error. If the temperature displayed is reasonable, the error will be in the return temperature sensor (Horizontal Pipe). If the temperature displayed is not reasonable, the error will be in the supply sensor (Vertical Pipe).</li> <li>2. Check the electrical connection to the thermistor on the outlet manifold. Check the wiring harness. If both are connected properly, replace the control. <b>NOTE:</b> Verify the thermistor values by referencing the Resistance Tables in Section 12.</li> <li>3. Replace thermistor if necessary.</li> </ol>
<b>Fault Code ECS NOT CONNECTED</b>		
ECS NOT CONNECTED PUMP OFF	This indicates the main control board and the smaller ECS control board are not communicating properly. This error allows the tank portion of the unit to still operate, but will not allow the hydronic heating module to operate until the error is cleared. The second line indicates the status of the pump.	<ol style="list-style-type: none"> <li>1. Ensure both ends of the ribbon cable are connected properly and securely in place.</li> <li>2. Next, check the ribbon cable for damage or wear. If any problems are found, replace the ribbon cable.</li> <li>3. If problem still occurs with the new ribbon cable, replace the ECS board.</li> </ol>
<b>Fault Code TEMPER BLOCKING</b>		
TEMPER BLOCKING PUMP ON 12:31P	This indicates a temporary hold on the burner ignition, and occurs when the top tank sensor is above the set point and the bottom of the tank is substantially cooler than the top. This is a temporary hold on the burner only and all other functions will remain functioning properly. This error will clear itself when either the top tank temperature drops below the set point or the bottom temperature rises.	
<b>Fault Code E19</b>		
LINE VOLTAGE E19 PUMP OFF	This display indicates that the line voltage frequency is out of range. This could happen if the unit is being powered from a small gasoline powered generator that is not functioning correctly or overloaded.	Inspect power wiring to unit and repair as necessary. If connected to line voltage, notify electric utility company. If connected to alternate power source such as generator or inverter, make sure the line voltage frequency supplied by the device is 60 Hz.
<b>Fault Code FLU</b>		
HI FLUE PRESS FLU PUMP ON	This display indicates that there is excessive flue pressure. This code will reset automatically after the high pressure condition is resolved. The second line indicates the status of the pump.	<ol style="list-style-type: none"> <li>1. Assure that the flue is not blocked.</li> <li>2. Check the switch wiring by applying a jumper in place of the switch. If the code clears with the jumper in place, REPLACE the flue switch and connect the wires to the new switch BEFORE running unit.</li> </ol> <div style="border: 1px solid black; padding: 5px; margin-top: 10px;"> <p style="text-align: center;"><b>⚠ WARNING</b></p> <p>Do not use a jumper to remedy this error. A faulty switch <b>MUST</b> be replaced. Failure to do so could result in serious injury or death.</p> </div>
<b>Fault Code LEO</b>		
LOW WATER LEVEL LEO PUMP OFF	This display indicates that there is a low water level in the main tank. This code will not allow the unit to run until correct water level is restored. The second line indicates the status of the pump. Note: While the water level is low, the pump will be off.	<ol style="list-style-type: none"> <li>1. Assure that there is adequate pressure and flow from the cold water inlet by slightly opening the drain valve near the tank.</li> <li>2. Assure the DHW system has all air removed through a high point hot water source, i.e. sink faucet.</li> <li>3. Check wiring and probes. Replace if necessary.</li> </ol>
<b>Fault Code LOU</b>		
24 VOLT LOW LOU PUMP ON	This display indicates that the 24 volt power supply on the control is damaged or overloaded. This code will reset automatically if it is the result of an overload and that overload condition is removed. The second line indicates the status of the pump. Note: While 24 volt power is low, the pump output will be on.	<ol style="list-style-type: none"> <li>1. Ensure line voltage is between 100-128 volts.</li> <li>2. Disconnect TT wiring. If error clears, there is an issue in the thermostat wiring. Review external wiring.</li> <li>3. If available, connect PC and use HTP service software to check the 24v supply display in the lower left corner of the screen. The number displayed here must be greater than 128 and should be at least 250. Use this as a troubleshooting guide as you follow the steps below.</li> <li>4. Remove 12 pin Molex connector from the field wiring board. If the message clears, then the problem is with external low voltage wiring. Examine the external low voltage sensor wiring for shorts to ground and repair as necessary. If message is still present, disconnect the UL 353 low water cutoff to see if message clears. Replace faulty part. Check low voltage wire harness in appliance for shorts to ground.</li> <li>5. Remove the 20 pin Molex from the ECS board. If the message clears, examine the wiring to the heating module and fan for shorts or grounds and repair as necessary.</li> <li>6. If message only occurs when the burner tries to light, check gas valve for excessive current draw.</li> <li>7. If message is present with the low voltage harness disconnected from the 926 control board, replace the 926 control board.</li> </ol>

Fault Code F00		
WATER HIGH TEMP F00 PUMP ON	This display indicates that the water in the tank has overheated. This is a serious safety issue, as indicated by the red fault light and the flashing the word LOCKOUT on the display. The unit will not restart until it cools sufficiently and a technician repairs the cause of overheating and resets the unit. During this lockout fault, the pump will be on as indicated on the second line of the display in an effort to cool down the appliance.	<ol style="list-style-type: none"> <li>1. Check central heating pump operation.</li> <li>2. If the circulator pump is running, ensure there is water in the system and that water is moving through the system as intended. Ensure that all ball valves and or zone valves are open or closed as intended.</li> <li>3. Observe the temperature/pressure gauge. If the water is not hot and this message is displayed, check the wiring to the water eco sensor and repair if necessary.</li> <li>4. If the wiring is intact, water is not excessively hot and this code is still present, replace the eco sensor.</li> </ol>
Fault Code F01		
FLUE TEMP F01 PUMP ON	This display indicates that the flue temperature limit switch of the unit has tripped. This is a serious safety issue, as indicated by the red fault light and the word LOCKOUT flashing on the display. The unit will not restart until the flue cools down sufficiently and a technician repairs the cause of the problem and pushes the <b>RESET</b> button on both the device and the display. During this lockout fault, the pump will be on as indicated on the second line of the display.	<ol style="list-style-type: none"> <li>1. Check the flue for obstructions or any sign of damage (especially signs of excessive heat). Repair as necessary.</li> <li>2. Push the red reset button on the flue temperature switch located on CPVC vent elbow. NOTE: Switch temperature must be less than 90°F to reset.</li> <li>3. Press <b>RESET</b> on the display. Run the unit and check the flue temperature by using an external thermometer in the flue pipe. If the flue temperature is below 190°F and the switch trips, replace the switch. If the flue temperature is excessive, check and adjust the combustion controls on the unit.</li> </ol>
Fault Code F02		
TOP TEMP SENSOR F02 PUMP ON	This display indicates that the top temperature sensor of the tank has failed. This code indicates a serious safety issue by the red fault light and the word LOCKOUT flashing on the display. The unit will not restart until a technician replaces the sensor and resets the unit. During this lockout fault, the circulator pump will be on as indicated on the second line of the display.	<ol style="list-style-type: none"> <li>1. Check the electrical connection to the thermistor on the outlet manifold. Verify 5 VDC by checking in Molex connector. If no 5 VDC, check harness. If harness is OK, replace control. NOTE: Verify thermistor values by referencing chart in this manual.</li> <li>2. Replace thermistor if necessary.</li> </ol>
Fault Code F03		
BOT TEMP SENSOR F03 PUMP ON	This display indicates that the bottom temperature sensor of the unit has failed. This code indicates a serious safety issue by the red fault light and the word LOCKOUT flashing on the display. The unit will not restart until a technician replaces and resets the unit. During this lockout fault, the pump will be on as indicated on the second line of the display.	<ol style="list-style-type: none"> <li>1. Check the electrical connection to the thermistor. Check the wire harness. If harness is OK, replace control. NOTE: Verify thermistor values by referencing chart in this manual.</li> <li>2. Replace thermistor if necessary.</li> </ol>
Fault Code F05		
TOP TEMP HIGH F05 PUMP ON	This display indicates the top temperature of the tank is excessive. If accompanied by the illuminated red fault light and LOCKOUT flashing on the display, then this code indicates that the temperature on the top sensor has exceeded 230°F and a serious safety issue exists. The unit will not restart until a technician repairs the cause of excessive temperature and resets the unit. If the red fault light is not illuminated and this message is displayed, the top temperature of the tank is at or above 210°F. The message will clear automatically when the temperature drops below 194°F. While this message or lockout fault is displayed, the pump will be on as indicated on the bottom line.	<ol style="list-style-type: none"> <li>1. Check the electrical connection to the thermistor on the outlet manifold. Verify 5 VDC by checking in Molex connector. If not 5 VDC, check harness. If harness is OK, replace control. NOTE: Verify thermistor values by referencing the resistance table in Part 12.</li> <li>2. Replace thermistor if necessary.</li> </ol>
Fault Code F06		
BOT TEMP HIGH F06 PUMP ON	This display indicates that the bottom temperature of the tank is excessive. If this code is accompanied by the illuminated red fault light and LOCKOUT flashing on the display, then the temperature on the bottom sensor has exceeded 230°F and a serious safety issue exists. The appliance will not restart until a technician repairs the cause of the excessive temperature and resets the unit. If the red fault light is not illuminated and this message is displayed then the bottom temperature of the tank is at or above 210°F. The message will clear automatically when the temperature drops below 194° F. During the time that this message or lockout fault is displayed, the pump will be on as indicated on the bottom line of the display.	<ol style="list-style-type: none"> <li>1. Check the electrical connection to the thermistor on the outlet manifold. Verify 5 VDC by checking in Molex connector. If not 5 VDC, check harness. If harness is OK, replace control. NOTE: Verify thermistor values by referencing chart in this manual.</li> <li>2. Replace thermistor if necessary.</li> </ol>

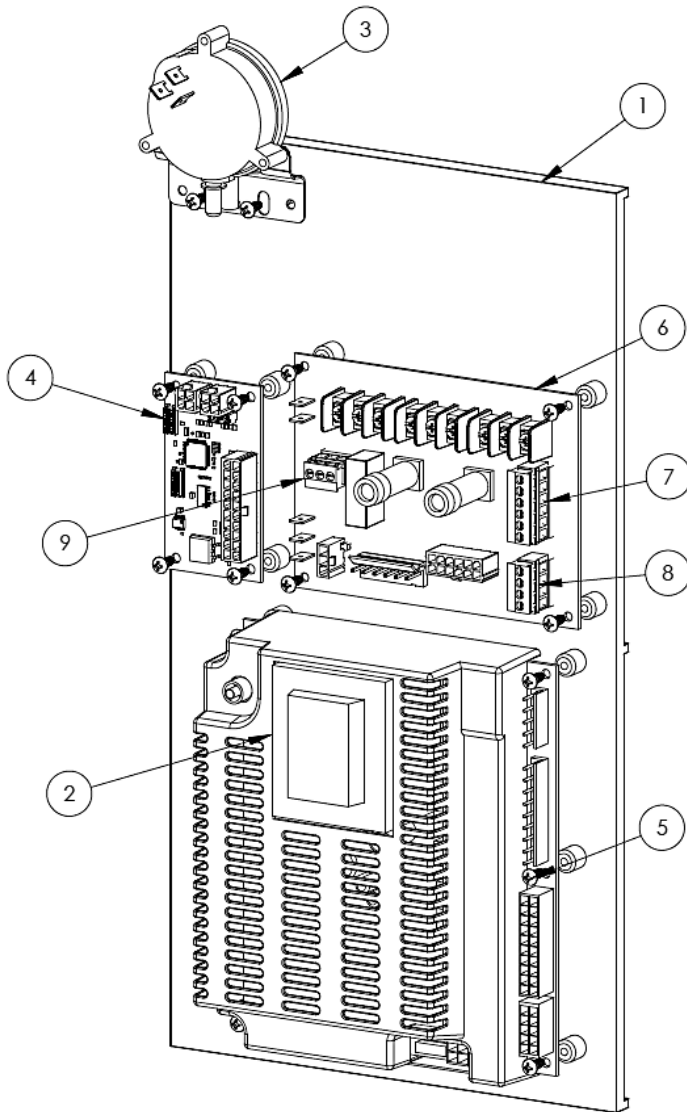
Fault Code F09		
NO FLAME ON IGN F09 PUMP ON	The unit tried to ignite four times during a call for heat and failed ignition all four times. This code indicates a serious safety issue. The unit will not restart until a technician repairs the cause of no ignition and resets the display. The red fault light and word LOCKOUT will flash on the display. During this lockout fault, the pump will be on as indicated on the bottom line.	<ol style="list-style-type: none"> <li>1. Watch the igniter through the observation window.</li> <li>2. If there is no spark, for natural gas units check the spark electrode for the proper gap. Use 2 quarters together as a gauge to check gap spacing.</li> <li>3. Remove any corrosion from the spark electrode and flame rectifier probe.</li> <li>4. If there is a spark but no flame, check the gas supply to the appliance.</li> <li>5. If there is a flame, check the flame sensor.</li> <li>6. Check for any flue blockage or condensate blocks.</li> </ol>
Fault Code F10		
FLAME LOSS F10	The flame was lost while the unit was lit 3 times during 1 demand call. The red fault light and the word LOCKOUT flashing on the display indicate a serious safety issue. The unit will not restart until the technician repairs the cause of flame loss and resets the unit. During this lockout fault, the pump will be on as indicated on the bottom line of the display.	<ol style="list-style-type: none"> <li>1. Monitor gas pressure to the unit while in operation.</li> <li>2. Assure that the flame is stable when lit.</li> <li>3. Check to see if the display readout changes from "GAS VALVE ON" to "RUN" within a few seconds after the appliance ignites</li> <li>4. Check the FLAME signal on the status display. It should be above 1.0 when the unit is firing.</li> <li>5. If the signal reads less than 1 microampere, clean the flame rectifier and spark probe.</li> <li>6. If the problem persists and the 'FLAME" signal is still less than 1.0, replace the flame probe and spark igniter probe.</li> <li>7. The flame signal should be steady after the unit has been firing for 1 minute and is normally at 5.0 to 9.0. If not steady, disassemble the burner door and check the burner and its sealing gaskets.</li> </ol>
Fault Code F11		
FALSE FLAME SIG F11 PUMP ON	There is flame when the control is not telling the unit to run. The red fault light and the word LOCKOUT flashing on the display indicate that this code is serious safety issue. The unit will not restart until a technician repairs the cause of the lockout and resets the unit. During this lockout fault, the pump will be on as indicated on the second line of the display.	<ol style="list-style-type: none"> <li>1. Look into window. If there is flame, turn the gas off to the unit at the service valve and replace the gas valve.</li> <li>2. If the flame signal on the status menu is greater than 1.0 when the burner is not lit, replace the spark igniter and the flame rectification probe.</li> <li>3. If the flame signal is not present after turning off the gas supply, check the gas valve electrical connection.</li> <li>4. Check for condensate backup. Repair the condensate system as necessary. If condensate has partially filled the combustion chamber, the refractory wall may be damaged and should be replaced.</li> <li>5. Turn the gas on at the service valve after corrective action is taken.</li> </ol>
Fault Code F13		
FAN SPEED ERROR F13 PUMP ON	The fan speed had been more than 30% faster or slower than the control commanded speed for more than 10 seconds. The red fault light and flashing LOCKOUT on the display indicates a serious safety issue. The unit will not restart until the technician repairs and resets the unit. During this lockout fault, the pump will be on as indicated on the second line of the display.	<ol style="list-style-type: none"> <li>1. Check the combustion air fan wiring.</li> <li>2. Measure the DC voltage from the red fan wire to ground while it is connected to the fan. It should be between 24 to 40 volts. If it is lower than 24 volts, check for excessive external loads connected to the sensor terminals. Disconnect the 5 pin plug from the fan and check the voltage on the red wire again. If it is now between 24-40 volts, replace the fan. If it is still below 24 volts replace the appliance control board.</li> </ol>
Fault Code F31		
PROGRAM ERROR F31	There was an error while programming the control. The control's memory could be corrupt. The appliance control will not function in this state and the pump will be off. The only way to recover from this error is to reprogram the control. If this error occurs at any time other than when a technician is servicing the unit, the control has failed and must be replaced.	Control must be reprogrammed. If reprogramming does not solve problem, control must be replaced.
Fault Code PP		
CONTROL PROGRAMED PP	The control has been programmed by a technician or the factory. After programming, the control was left in a locked out mode. Press <b>RESET</b> to begin use of the control.	Press <b>RESET</b> for at least one second.

Table 19 – Fault Codes



Item #	Description	Replacement Part #
1	LOW WATER CUT-OFF SENSOR	7100P-852-1
2	HIGH TEMP SAFETY SWITCH	7100P-006
3	UPPER TEMPERATURE SENSOR	7100P-004
4	BRAZED PLATE HEAT EXCHANGER	7100P-132
5	SEALING WASHER - BSPP NUT	8600P-044
6	THUMB SCREW - HYDRONIC MODULE COVER	7100P-149
7	FLEX LINE - EXCHANGER SIDE (w/NUTS, WASHERS)	7100P-171
8	LOWER TEMPERATURE SENSOR	7100P-005
9	2" COUPLING - AIR INLET (130K BTU)	7100P-114
	3" COUPLING - AIR INLET (199K BTU)	7100P-103
10	CONDENSATE HOSE	7100P-121
11	CLAMP - CONDENSATE HOSE	7250P-215
12	HIGH FLUE TEMP SWITCH	VS210
13	S.S. HOSE BARB	7250P-154
14	COUPLING NUT - AIR INLET	7100P-104
15	55-80 GAL. PLASTIC CABINET	7100P-264
	199 GAL. PLASTIC CABINET	7100P-265
16	CONTROL BOARD DISPLAY (w/MEMBRANE, BOARD, HOUSING, CABLE)	7100P-266
17	POWER SWITCH	7500P-087
18	55-80 GAL. HYDRONIC MODULE BACKPLATE	7100P-156
	199 GAL. HYDRONIC MODULE BACKPLATE	7100P-135
19	FLEX LINE - PUMP SIDE (w/NUTS, WASHERS)	7100P-165
20	HYDRONIC HEATING MODULE PUMP	7100P-131
21	TEMPERATURE AND PRESSURE RELIEF VALVE	TP1400
22	CLIP-ON PIPE TEMPERATURE SENSOR	7100P-172
23	55-80 GAL. HYDRONIC MODULE COVER	7100P-134
	199 GAL. HYDRONIC MODULE COVER	7100P-136

Figure 29



Item #	Description	Replacement Part #
1	ELECTRONIC BACK PLATE	7100P-102
2	CONTROL BOARD	7450P-122
3	SWITCH, PRESSURE, BLOCKED VENT	7250P-150
4	ECS BOARD	7100P-108
5	ELECTRONIC MOUNTING SCREW	N/A
6	FIELD CONNECTION BOARD	7100P-083
7	6 PIN TERMINAL BLOCK	7100P-254
8	4 PIN TERMINAL BLOCK	7100P-255
9	3 PIN TERMINAL BLOCK	7100P-256
10	ECS RIBBON CABLE (NOT SHOWN)	7100P-221
11	LOW VOLTAGE WIRE HARNESS (NOT SHOWN)	7100P-257
12	HIGH VOLTAGE WIRE HARNESS (NOT SHOWN)	7100P-258
13	HYDRONIC MODULE WIRE HARNESS (NOT SHOWN)	7100P-259
14	SENSOR WIRE HARNESS (NOT SHOWN)	7100P-274

Figure 30 – LP-314-G

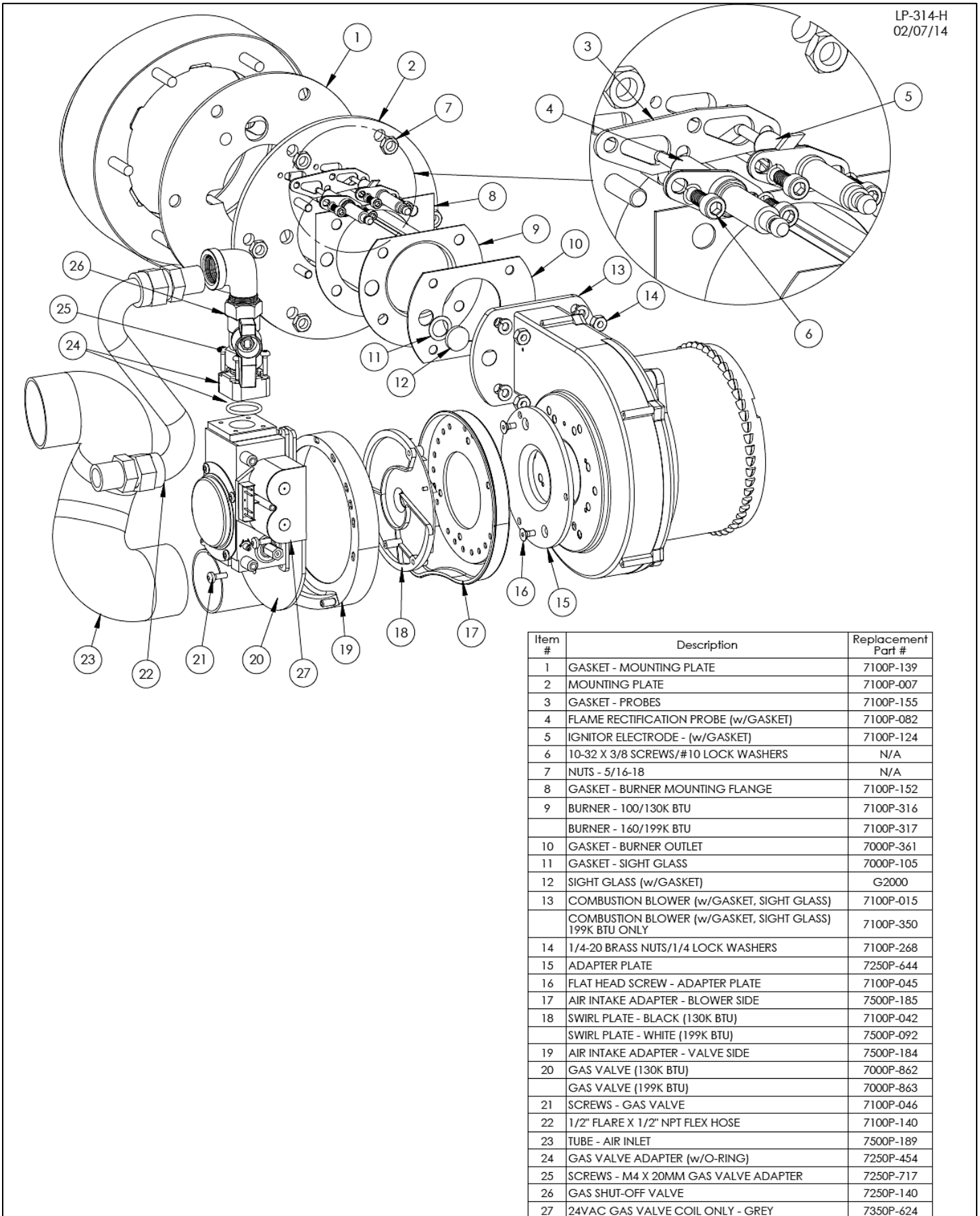


Figure 31



## PART 13 – MAINTENANCE

### CAUTION

In unusually dirty or dusty conditions, care must be taken to keep appliance cabinet door in place at all times. Failure to do so VOIDS WARRANTY!

### WARNING

Allowing the appliance to operate with a dirty combustion chamber will hurt operation. Failure to clean the heat exchanger as needed by the installation location could result in appliance failure, property damage, personal injury, or death. Such product failures ARE NOT covered under warranty.

The appliance requires minimal periodic maintenance under normal conditions. However, in unusually dirty or dusty conditions, periodic vacuuming of the cover to maintain visibility of the display and indicators is recommended.

Periodic maintenance should be performed once a year by a qualified service technician to assure that all the equipment is operating safely and efficiently. The owner should make necessary arrangements with a qualified heating contractor for periodic maintenance of the appliance. Installer must also inform the owner that the lack of proper care and maintenance of the appliance may result in a hazardous condition.

INSPECTION ACTIVITIES		DATE LAST COMPLETED			
		1 <sup>st</sup> YEAR	2 <sup>nd</sup> YEAR	3 <sup>rd</sup> YEAR	4 <sup>th</sup> YEAR*
<b>PIPING</b>					
Near appliance piping	Check appliance and system piping for any sign of leakage; make sure they are properly supported.				
Vent	Check condition of all vent pipes and joints. Ensure the vent piping terminations are free of obstructions and blockages.				
Gas	Check Gas piping, test for leaks and signs of aging. Make sure all pipes are properly supported.				
<b>SYSTEM</b>					
Visual	Do a full visual inspection of all system components.				
Functional	Test all functions of the system (Heat, Safeties)				
Temperatures	Verify safe settings on appliance or Anti-Scald Valve				
Temperatures	Verify programmed temperature settings				
<b>ELECTRICAL</b>					
Connections	Check wire connections. Make sure they are tight.				
Smoke and CO detector	Verify devices are installed and working properly. Change batteries if necessary.				
Circuit Breakers	Check to see that the circuit breaker is clearly labeled. Exercise circuit breaker.				
<b>CHAMBER/BURNER</b>					
Combustion Chamber	Check burner tube and combustion chamber coils. Clean and vacuum according to maintenance section of manual. Replace any gaskets that show signs of damage.				
Spark Electrode	Clean. Set gap at 1/4".				
Flame Probe	Clean. Check ionization in uA (d7 on status menu in Start-up Procedures). Record high fire and low fire.				
<b>CONDENSATE</b>					
Neutralizer	Check condensate neutralizer. Replace if necessary.				
Condensate hose	Disconnect condensate hose. Clean out dirt. Fill with water to level of outlet and re-install. (NOTE: Verify the flow of condensate, making sure that the hose is properly connected during final inspection.)				
<b>GAS</b>					
Pressure	Measure incoming gas pressure (3.5" to 10" W.C. for Natural Gas, 8" – 14" W.C for LP)				
Pressure Drop	Measure drop in pressure on light off (no more than 1" W.C.)				
Check for gas leaks	Check piping for leaks. Verify that all are properly supported.				
<b>COMBUSTION</b>					
CO/CO2 Levels	Check CO and CO2 levels in Exhaust (See Start-up Procedures for ranges). Record at high and low fire.				
<b>SAFETIES</b>					
ECO (Energy Cut Out)	Check continuity on Flue and Water ECO. Replace if corroded.				
Water Pressure Switch	Check operation and for signs of leakage. Replace if corroded.				
Thermistors	Check wiring. Verify through ohms reading.				
<b>FINAL INSPECTION</b>					
Check list	Verify that you have completed entire check list. WARNING: FAILURE TO DO SO COULD RESULT IN SERIOUS INJURY OR DEATH.				
Homeowner	Review what you have done with the homeowner.				

Table 20 - \*Continue annual maintenance beyond the 4<sup>th</sup> year as required.

## ADDITIONAL INSTALLATION REQUIREMENTS FOR THE COMMONWEALTH OF MASSACHUSETTS

In the Commonwealth of Massachusetts, the installer or service agent shall be a plumber or gas fitter licensed by the Commonwealth.

When installed in the Commonwealth of Massachusetts or where applicable state codes may apply; the unit shall be installed with a CO detector per the requirements listed below.

5.08: Modifications to NFPA-54, Chapter 10

(1) Revise NFPA-54 section 10.5.4.2 by adding a second exception as follows:

Existing chimneys shall be permitted to have their use continued when a gas conversion burner is installed, and shall be equipped with a manually reset device that will automatically shut off the gas to the burner in the event of a sustained back-draft.

(2) Revise 10.8.3 by adding the following additional requirements:

(a) For all side wall horizontally vented gas fueled equipment installed in every dwelling, building or structure used in whole or in part for residential purposes, including those owned or operated by the Commonwealth and where the side wall exhaust vent termination is less than seven (7) feet above finished grade in the area of the venting, including but not limited to decks and porches, the following requirements shall be satisfied:

1. INSTALLATION OF CARBON MONOXIDE DETECTORS. At the time of installation of the side wall horizontal vented gas fueled equipment, the installing plumber or gasfitter shall observe that a hard wired carbon monoxide detector with an alarm and battery back-up is installed on the floor level where the gas equipment is to be installed. In addition, the installing plumber or gasfitter shall observe that a battery operated or hard wired carbon monoxide detector with an alarm is installed on each additional level of the dwelling, building or structure served by the side wall horizontal vented gas fueled equipment. It shall be the responsibility of the property owner to secure the service of qualified licensed professionals for the installation of hard wired carbon monoxide detectors

a. In the event that the side wall horizontally vented gas fueled equipment is installed in a crawl space or an attic, the hard wired carbon monoxide detector with alarm and battery back-up may be installed on the next adjacent floor level.

b. In the event that the requirements of this subdivision cannot be met at the time of completion of installation, the owner shall have a period of thirty (30) days to comply with the above requirements; provided, however, that during said thirty (30) day period, a battery operated carbon monoxide detector with an alarm shall be installed.

2. APPROVED CARBON MONOXIDE DETECTORS. Each carbon monoxide detector as required in accordance with the above provisions shall comply with NFPA 720 and be ANSI/UL 2034 listed and IAS certified.

3. SIGNAGE. A metal or plastic identification plate shall be permanently mounted to the exterior of the building at a minimum height of eight (8) feet above grade directly in line with the exhaust vent terminal for the horizontally vented gas fueled heating appliance or equipment. The sign shall read, in print size no less than one-half (1/2) inch in size, "GAS VENT DIRECTLY BELOW, KEEP CLEAR OF ALL OBSTRUCTIONS".

4. INSPECTION. The state or local gas inspector of the side wall horizontally vented gas fueled equipment shall not approve the installation unless, upon inspection, the inspector observes carbon monoxide detectors and signage installed in accordance with the provisions of 248 CMR 5.08 (2)(a) 1 through 4.

(b) EXEMPTIONS: the following equipment is exempt from 248 CMR 5.08 (2)(a) 1 through 4:

1. The equipment listed in Chapter 10 entitled "Equipment Not Required to be Vented" in the most current edition of NFPA 54 as adopted by the Board; and
2. Product Approved side wall horizontally vented gas fueled equipment installed in a room or structure separate from the dwelling, building or structure used in whole or in part for residential purposes.

(c) MANUFACTURER REQUIREMENTS – GAS EQUIPMENT VENTING SYSTEM PROVIDED. When the manufacturer of Product Approved side wall horizontally vented gas equipment provides a venting system design or venting system components with the equipment, the instructions provided by the manufacturer for installation of the equipment and the venting system shall include:

1. Detailed instructions for the installation of the venting system design or the venting system components; and
2. A complete parts list for the venting system design or venting system.

(d) MANUFACTURER REQUIREMENTS – GAS EQUIPMENT VENTING SYSTEM NOT PROVIDED. When the manufacturer of a Product Approved side wall horizontally vented gas fueled equipment does not provide the parts for venting the flue gases, but identifies "special venting systems", the following requirements shall be satisfied by the manufacturer:

1. The referenced "special venting system" instructions shall be included with the appliance or equipment installation instructions; and
2. The "special venting systems" shall be Product Approved by the Board, and the instructions for that system shall include a parts list and detailed installation instructions.

(e) A copy of all installation instructions for all Product Approval side wall horizontally vented gas fueled equipment, all venting instructions, all parts lists for venting instructions, and/or all venting design instructions shall remain with the appliance or equipment at the completion of the installation.



### HTP CUSTOMER INSTALLATION RECORD FORM

The following form should be completed by the installer for you to keep as a record of the installation in case of a warranty claim. After reading the important notes at the bottom of the page, please also sign this document.

Customer's Name:	
Installation Address:	
Date of Installation:	
Installer's Code/Name:	
Product Serial Number(s):	
Comments:	
Installer's Phone Number:	
Signed by Installer:	
Signed by Customer:	

**IMPORTANT:**

**Customer:** Please only sign after the installer has reviewed the installation, safety, proper operation and maintenance of the system. In the case that the system has any problems, please call the installer. If you are unable to make contact, please contact your HTP Sales Representative.

*Distributor/Dealer:* Please insert contact details.