



# Elite FT

## Residential and Commercial Boilers

Installation

Start-Up

Maintenance

Parts

Warranty

EFT-55 / EFT-80 / EFT-110  
EFT-155 / EFT-199 / EFT-285  
EFT-399  
Models\*

\* "LP" Denotes Propane Gas Operation  
"PU" Denotes Included Pump

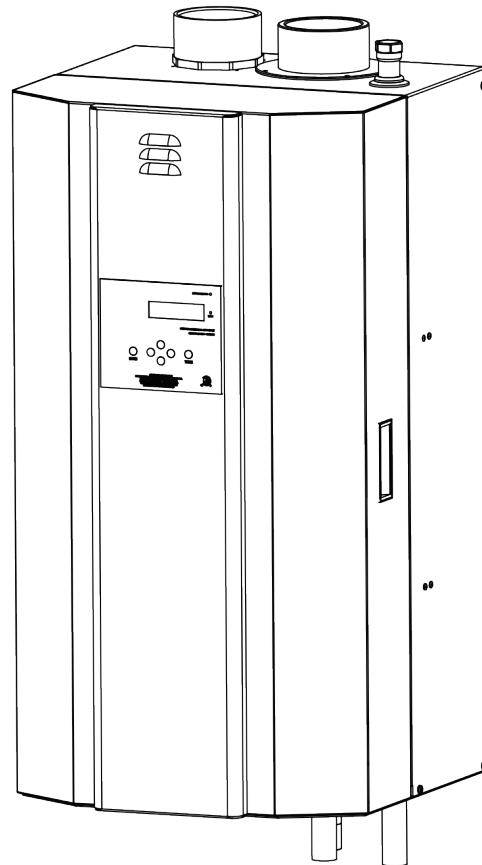

Heat Exchanger Bears the ASME "H" Stamp



### **▲ DANGER**

This manual must only be used by a qualified installer / service technician. Read all instructions in this manual before installing. Perform steps in the given order. Failure to do so could result in substantial property damage, severe personal injury, or death.

### **▲ WARNING**

Improper installation, adjustment, alteration, service, or maintenance could void product warranty and cause property damage, severe personal injury, or death.

### **NOTICE**

HTP reserves the right to make product changes or updates without notice and will not be held liable for typographical errors in literature.

**NOTE TO CONSUMER: PLEASE KEEP ALL INSTRUCTIONS FOR FUTURE REFERENCE.**

## ▲ WARNING

**IF THE INFORMATION IN THIS MANUAL IS NOT FOLLOWED EXACTLY, A FIRE OR EXPLOSION MAY RESULT, CAUSING PROPERTY DAMAGE, PERSONAL INJURY, OR LOSS OF LIFE. DO NOT STORE GASOLINE OR OTHER FLAMMABLE VAPORS AND LIQUIDS IN THE VICINITY OF THIS OR ANY OTHER APPLIANCE.**

### WHAT TO DO IF YOU SMELL GAS

- Do not try to light any appliance.
- Do not touch any electrical switch.
- Do not use any phone in your building.
- Immediately call your gas supplier from a neighbor's phone. Follow the gas supplier's instructions.
- If you cannot reach your gas supplier, call the fire department. Installation and service must be provided by a qualified installer, service agency, or the gas supplier.

## FOR YOUR SAFETY READ BEFORE OPERATING

**WARNING: If you do not follow these instructions exactly, a fire or explosion may result, causing property damage, personal injury or loss of life.**

- |   |   |
|---|---|
| <p>A. This appliance does not have a pilot. It is equipped with an ignition device which automatically lights the burner. Do <u>not</u> try to light the burner by hand.</p> <p>B. <b>BEFORE OPERATING</b> smell all around the appliance area for gas. Be sure to smell next to the floor because some gas is heavier than air and will settle on the floor.</p> | <ul style="list-style-type: none"> <li>• If you cannot reach your gas supplier, call the fire department.</li> </ul> <p>C. Use only your hand to turn the gas control knob. Never use tools. If the handle will not turn by hand, don't try to repair it, call a qualified service technician. Force or attempted repair may result in a fire or explosion.</p> |
|---|---|

### WHAT TO DO IF YOU SMELL GAS

- |   |  |
|---|--|
| <ul style="list-style-type: none"> <li>• Do not try to light any appliance</li> <li>• Do not touch any electric switch; do not use any phone in your building</li> <li>• Immediately call your gas supplier from a neighbor's phone. Follow the gas suppliers' instructions.</li> </ul> | <p>D. Do not use this appliance if any part has been under water. Immediately call a qualified service technician to inspect the appliance and to replace any part of the control system and any gas control which has been under water.</p> |
|---|--|

## OPERATING INSTRUCTIONS

- |   |   |
|---|---|
| <ol style="list-style-type: none"> <li>1. STOP! Read the safety information above.</li> <li>2. Set the thermostat to lowest setting.</li> <li>3. Turn off all electric power to the appliance.</li> <li>4. This appliance is equipped with an ignition device which automatically lights the burner. Do not try to light the burner by hand.</li> </ol> | <ol style="list-style-type: none"> <li>5. Remove front cover.</li> <li>6. Turn gas shutoff valve to "off". Handle will be across the piping, do not force.</li> <li>7. Wait five (5) minutes to clear out any gas. If you then smell gas, STOP! Follow "B" in the safety information above on this label. If you don't smell gas, go to next step.</li> <li>8. Turn gas shutoff valve to "on". Handle will be in line with piping.</li> <li>9. Install Front Cover.</li> <li>10. Turn on all electric power to appliance.</li> <li>11. Set thermostat to desired setting.</li> <li>12. If the appliance will not operate, follow the instructions "To Turn Off Gas To Appliance" and call your service technician or gas supplier.</li> </ol> |
|---|---|

GAS VALVE  
ON

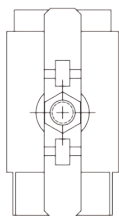

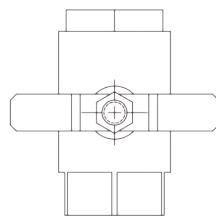

GAS VALVE  
OFF



## TO TURN OFF GAS TO APPLIANCE

- |  |  |
|--|--|
| <ol style="list-style-type: none"> <li>1. Set the thermostat to lowest setting.</li> <li>2. Turn off all electric power to the appliance if service is to be performed.</li> <li>3. Remove Front Cover.</li> </ol> | <ol style="list-style-type: none"> <li>4. Turn gas shutoff valve to "off". Handle will be across the piping. Do not force.</li> <li>5. Install Front Cover.</li> </ol> |
|--|--|

LP-175 Rev. 4 3-11-08

<b>SPECIAL ATTENTION BOXES</b>	
The following defined terms are used throughout this manual to bring attention to the presence of hazards of various risk levels or to important product information.	
	<b>DANGER</b>
<b>DANGER</b> indicates an imminently hazardous situation which, if not avoided, will result in serious personal injury or death.	
	<b>WARNING</b>
<b>WARNING</b> indicates a potentially hazardous situation which, if not avoided, could result in personal injury or death.	
	<b>CAUTION</b>
<b>CAUTION</b> indicates a potentially hazardous situation which, if not avoided, may result in moderate or minor personal injury.	
<b>CAUTION</b>	
<b>CAUTION</b> used without the safety alert symbol indicates a potentially hazardous situation which, if not avoided, may result in property damage.	
<b>NOTICE</b>	
<b>NOTICE</b> is used to address practices not related to personal injury.	

**Foreword**

This manual is intended to be used in conjunction with other literature provided with the boiler. This includes all related control information. It is important that this manual, all other documents included in this system, and additional publications including the *Code for the Installation of Heat Producing Appliances* and *National Fuel Gas Code - ANSI Z223.1* (latest versions), be reviewed in their entirety before beginning any work.

Installation should be made in accordance with the regulations of the Authority Having Jurisdiction, local code authorities, and utility companies which pertain to this type of water heating equipment.

Authority Having Jurisdiction (AHJ) – The AHJ may be a federal, state, local government, or individual such as a fire chief, fire marshal, chief of a fire prevention bureau, labor department or health department, building official or electrical inspector, or others

having statutory authority. In some circumstances, the property owner or his/her agent assumes the role, and at government installations, the commanding officer or departmental official may be the AHJ.

**NOTE:** HTP, Inc. reserves the right to modify product technical specifications and components without prior notice.

**For the Installer**

This boiler must be installed by qualified and licensed personnel. The installer should be guided by the instructions furnished with the boiler, and by local codes and utility company requirements. In the absence of local codes, preference should be given to the *National Fuel Gas Code - ANSI Z223.1*, latest version.

**Installations Must Comply With:**

Local, state, provincial, and national codes, laws, regulations, and ordinances.

The latest version of the *National Fuel Gas Code, ANSI Z223.1*, from American Gas Association Laboratories, 8501 East Pleasant Valley Road, Cleveland, OH 44131.

In Canada - *CGA No. B149* (latest version), from Canadian Gas Association Laboratories, 55 Scarsdale Road, Don Mills, Ontario, Canada M3B 2R3. Also, *Canadian Electrical Code, C 22.1*, from Canadian Standards Association, 5060 Spectrum Way, Suite 100, Mississauga, Ontario, Canada L4W 5N6.

*Code for the Installation of Heat Producing Appliances* (latest version) from American Insurance Association, 85 John Street, New York, NY 11038.

The latest version of the *National Electrical Code, NFPA No. 70*.

**NOTE:** The gas manifold and controls met safe lighting and other performance criteria when undergoing tests specified in *ANSI Z21.13* - latest edition.

<b>⚠ DANGER</b>	
	
<p><b>⚠ Vapors from flammable liquids will explode and catch fire causing death or severe burns.</b></p> <p>Do not use or store flammable products such as gasoline, solvents or adhesives in the same room or area near the water heater.</p> <p>Keep flammable products:</p> <ol style="list-style-type: none"> <li>1. far away from heater,</li> <li>2. in approved containers,</li> <li>3. tightly closed and</li> <li>4. out of children's reach.</li> </ol>	<p>Water heater has a main burner and pilot flame. The pilot flame:</p> <ol style="list-style-type: none"> <li>1. which can come on at any time and</li> <li>2. will ignite flammable vapors.</li> </ol> <p>Vapors:</p> <ol style="list-style-type: none"> <li>1. cannot be seen,</li> <li>2. are heavier than air,</li> <li>3. go a long way on the floor and</li> <li>4. can be carried from other rooms to the pilot flame by air currents.</li> </ol>
<p><b>Installation:</b></p> <p>Do not install water heater where flammable products will be stored or used unless the main burner and pilot flames</p>	<p>are at least 18" above the floor. This will reduce, but not eliminate, the risk of vapors being ignited by the main burner or pilot flame.</p>
<p>Read and follow water heater warnings and instructions. If owners manual is missing, contact the retailer or manufacturer.</p>	

## ⚠ WARNING

The hydronic supply and return connections of these products are for installation in closed loop systems **ONLY!** Use of this product in any manner other than described in this manual may result in premature product failure, substantial property damage, severe personal injury, or death. Damage or failure of this product (or the system in which it is installed) due to unauthorized use **IS NOT COVERED BY WARRANTY.**

## NOTICE

### IMPORTANT

In accordance with Section 325 (f) (3) of the Energy Policy and Conservation Act, HTP, Inc. has provided this boiler with multiple features designed to save energy by reducing the boiler water temperature as heating load decreases.

These features include:

- A modulating combustion system that adjusts firing rate based on heat demand.
- Adjustment of boiler set point based on inferred heat load as determined by an outdoor sensor. The outdoor sensor is supplied by HTP, Inc. with this boiler.
- This boiler does not include a standing pilot.
- This boiler is designed and shipped to assure the highest efficiency operation possible. Such high efficiency is achieved by limiting heating circuit water temperature to 140°F when there is no anticipated heat load, based upon the outdoor sensor and the Outdoor Reset Curve (sensor response curve) in the boiler software.
- This feature may be over-riden as described below in specific installations:
- The boiler control is equipped with an outdoor sensor override for use with building management systems or in cascaded systems (for systems with total input of 300,000 BTU/hr or greater).

See statement below for an important notice on the use of the override.

### IMPORTANT

In accordance with Section 325 (f) (3) of the Energy Policy and Conservation Act, this boiler is equipped with a feature that saves energy by reducing the boiler water temperature as the heating load decreases. This feature is equipped with an override which is provided primarily to permit the use of an external energy management system that serves the same function. **THIS OVERRIDE MUST NOT BE USED UNLESS AT LEAST ONE OF THE FOLLOWING CONDITIONS IS TRUE:**

- An external energy management system is installed that reduces the boiler water temperature as the heating load decreases.
- This boiler is not used for space heating.
- This boiler is part of a modular or multiple boiler system having a total input of 300,000 BTU/hr or greater.
- This boiler is equipped with a tankless coil.

The CSD-1 ASME Code, Section CW-4.00 requires that hot water heating and supply boilers have a) a UL 353 temperature control device, b) at least one (1) temperature-actuated control to shut off the fuel supply when system water reaches

a preset operating temperature, c) a high temperature limit control that prevents the water temperature from exceeding the maximum allowable temperature by causing a safety shutdown and lockout, and d) its own sensing element and operating switch.

The temperature control system integrated into the g26 control provided with this heating appliance complies with the requirements of CSD-1 Section CW-4.00 as a temperature operation control. The control monitors the temperature difference between the inlet and the outlet sensor, which is affected by boiler water flow. If this temperature difference exceeds 55°F (typically because of low water flow or very low heat load), the control will reduce the maximum fan speed. If the temperature difference exceeds 60°F, the control will effectively sense there is little or no water flow or heat load and shut the boiler down. The controller will restart automatically once the temperature difference has dropped below 55°F and the minimum off time (anti-cycle time) has expired. In addition, if the control senses that the outlet water temperature has reached 210°F, the boiler is put into a hard lockout and requires manual reset to restart.

### Table of Contents

Part 1 - General Safety Information	5
A. Improper Combustion	6
B. Gas	6
C. When Servicing the Boiler	6
D. Boiler Water	6
E. Freeze Protection	6
Part 2 - Before You Start	6
A. What's in the Box	6
B. How the Boiler Operates	7
C. Optional Equipment	7
Part 3 - Prepare the Boiler	8
A. Locating the Boiler	8
B. Structure	9
C. Leveling	9
D. Clearances for Service Access	9
E. Wall Mounting Considerations	10
F. Wall Mounting Instructions	10
1. Mounting to a Wood Studded Wall	10
2. Mounting to a Metal Frame	11
G. Residential Garage, Closet, and Alcove Installations	11
H. Exhaust Vent and Intake Pipe	11
1. Direct Vent of Exhaust and Intake	11
2. Indoor Combustion Air in Confined or Unconfined Space	12
I. Prevent Combustion Air Contamination	12
J. Removing a Boiler from a Common Vent System	12
I. Water Chemistry Requirements*	13
Part 4 - Piping	15
A. General Plumbing Information	15
B. Relief Valve	15
C. Backflow Preventer	15
D. Potable Expansion Tank	15
E. Circulators	16
F. Hydronic Piping with Circulators, Zone Valves, and Multiple Boilers	16
G. Circulator Sizing	16
H. Check / Control Water Chemistry	18
I. Plumbing	18

J. Fill and Purge Heating System	19	Part 10 - Start-Up Procedures for the Installer	53
K. Glycol Antifreeze Solutions	19	A. Boiler Control Status Menu	53
L. Zoning with Zone Valves	19	B. Cascade Menu	55
M. Zoning with Circulators	19	C. Boiler Test Mode	55
N. Multiple Boilers	19	Part 11 - Troubleshooting	56
O. Applications*	20	A. Boiler Error and Fault Codes	56
Part 5 - Venting and Condensate Removal	27	B. Boiler Error	56
A. General	27	C. Boiler Fault	56
B. Approved Materials for Exhaust Vent and Intake Pipe	28	D. User Interface Display	57
C. Additional Requirements for Installation in Canada	28	Part 12 - Maintenance	62
D. Exhaust Vent and Intake Pipe Location	29	A. Procedures	62
E. Exhaust Vent and Intake Pipe Sizing	30	B. Combustion Chamber Coil Cleaning Instructions	62
F. Longer Vent Runs	30	C. Cleaning Water Side of Heat Exchanger	63
G. Exhaust Vent and Intake Pipe Installation	30	D. Maintaining the Condensate System	63
H. Applications	31	Part 13 - Shutdown	64
1. Direct Vent Installation of Exhaust and Intake	31	A. Shutdown Procedure	64
2. Venting Through an Existing System	33	B. Vacation Procedure	64
3. Indoor Combustion Air in Confined or Unconfined Space	34	C. Failure to Operate	64
I. Condensate Removal System	34	Part 14 - Installation Checklist	69
Part 6 - Wiring	35	Part 15 - Maintenance Report	69
A. Installation Must Comply With	38	Limited Warranty	73
B. Field Wiring Terminations	38	Maintenance Notes	75
C. Field Wiring	38	Customer Installation Record Form	76
D. Line Voltage Wiring for Standard Boiler	38		
E. Alarm Connections	38		
F. Low Voltage Connections for Standard Boiler	38		
G. Thermostat	38		
H. Outdoor Sensor	38		
I. Indirect Sensor	38		
J. Optional 0-10 Volt Building Control Signal	38		
K. Optional UL353 Low Water Cut-Off Interface Kit	38		
L. Wiring of Cascade System Communication Bus	38		
M. Cascade Master Pump and Sensor Wiring	38		
N. Cascade Follower Pump and Sensor Wiring	38		
Part 7 - Gas Connections	38		
A. Gas Piping	38		
B. Check Inlet Gas Pressure	38		
C. Boiler Gas Valve	38		
Part 8 - Start-Up Preparation	38		
A. Check / Control Water Chemistry	38		
B. Check for Gas Leaks	38		
C. Freeze Protection (When Used)	38		
D. Fill and Test Water System	38		
E. Purge Air from Water System	38		
F. Check Thermostat Circuit(s)	38		
G. Condensate Removal	38		
H. Final Checks Before Starting Boiler	38		
I. Setting Up a Single Boiler	38		
J. Setting Up a Cascaded System	38		
K. Lockout Condition	38		
L. Cascade System Programming	38		
Part 9 - Start-Up Procedure	49		
A. Control Overview	49		
B. Navigation of the Display	49		
C. Operating Instructions	49		
D. Programming Boiler Settings	50		
E. Programming the System Setting	50		
F. System Setting Program Navigation	50		
G. Resetting the Maintenance Schedule	52		

**Part 1 - General Safety Information**

This boiler is approved for indoor installations only and is not intended for use as a pool heater. Clearance to combustible materials: 6" top, bottom, sides, and 0" back. Left side has all boiler mechanical connections. Boiler must have room for service: 24" front is minimum recommended service clearance. (A combustible door or removable panel is acceptable front clearance.) This boiler has been approved for closet installation and installation on combustible flooring. Do not install directly on carpeting. Install the boiler in a location where temperature and pressure relief valve discharge or a leak will not result in damage to the surrounding area. If such a location is not available, install an auxiliary catch pan. Use only Category IV vent systems.

 <b>WARNING</b>
<b>Installer</b> - Read all instructions in this manual before installing. Perform steps in the given order.
<b>User</b> - This manual is for use only by a qualified heating installer / service technician. Have this boiler serviced / inspected annually by a qualified service technician.
<b>FAILURE TO ADHERE TO THE GUIDELINES ON THIS PAGE CAN RESULT IN SUBSTANTIAL PROPERTY DAMAGE, SEVERE PERSONAL INJURY, OR DEATH.</b>
<b>NOTE:</b> If the boiler is exposed to the following, do not operate. Immediately call a qualified service technician.
<ol style="list-style-type: none"> <li>1. Fire</li> <li>2. Damage</li> <li>3. Water</li> </ol>
Failure to follow this information could result in property damage, severe personal injury, or death.
<b>NOTE:</b> Obey all local codes. Obtain all applicable permits before installing the boiler.
<b>NOTE:</b> Install all system components and piping in such a manner that does not reduce the performance of any fire rated assembly.

 <b>WARNING</b>
<b>DO NOT USE THIS BOILER IF ANY PART HAS BEEN SUBMERGED IN WATER.</b> Immediately call a qualified service technician. The boiler <b>MUST BE</b> replaced if it has been submerged. Attempting to operate a boiler that has been submerged could create numerous harmful conditions, such as a potential gas leakage causing a fire and/or explosion, or the release of mold, bacteria, or other harmful particulates into the air. Operating a previously submerged boiler could result in property damage, severe personal injury, or death. <b>NOTE:</b> Boiler damage due to flood or submersion is considered an Act of God, and IS NOT covered under product warranty.
Altering any HTP, Inc. boiler with parts not manufactured by HTP, Inc. <b>WILL INSTANTLY VOID</b> the boiler warranty and could result in property damage, personal injury, or death.
<b>CAUTION</b>
Do not use this boiler for anything other than its intended purpose (as described in this manual). Doing so could result in property damage and <b>WILL VOID</b> product warranty.
Due to the low water content of the boiler, improper sizing of the boiler with regard to heating system load will result in excessive cycling and accelerated component failure. HTP <b>DOES NOT</b> warrant failures caused by improperly sized boiler applications. <b>DO NOT</b> oversize the boiler to the system. Modular boiler installations greatly reduce the likelihood of boiler oversizing.
High heat sources (sources generating heat 100°F / 37°C or greater, such as stove pipes, space heaters, etc.) may damage plastic components of the boiler as well as plastic vent pipe materials. Such damages <b>ARE NOT</b> covered by warranty. It is recommended to keep a minimum clearance of 8" from high heat sources. Observe heat source manufacturer instructions, as well as local, state, provincial, and national codes, laws, regulations and ordinances when installing this boiler and related components near high heat sources.

#### A. Improper Combustion

 <b>WARNING</b>
Do not obstruct the flow of combustion and ventilating air. Adequate air is necessary for safe operation. Failure to keep the exhaust vent and combustion air intake clear of ice, snow, or other debris could result in property damage, serious personal injury, or death.

#### B. Gas

Should overheating or gas supply fail to shut off, turn off the manual gas control valve to the boiler.

#### C. When Servicing the Boiler

 <b>WARNING</b>
Be sure to disconnect electrical power before opening boiler cabinet or performing service. Failure to do so could result in electrical shock, property damage, serious personal injury, or death.

To avoid electric shock, disconnect electrical supply before performing maintenance.

**NOTE:** When inquiring about service or troubleshooting, reference the model and serial numbers from the boiler rating label.

To avoid severe burns, allow boiler and associated equipment to cool before servicing.

#### D. Boiler Water

- If you have an old system with cast iron radiators, thoroughly flush the system (without boiler connected) to remove sediment. The high-efficiency heat exchanger can be damaged by build-up or corrosion due to sediment. HTP recommends a suction strainer in this type of system.
- Do not use petroleum-based cleaning or sealing compounds in boiler system. Gaskets and seals in the system may be damaged, possibly resulting in substantial property damage.
- Do not use "homemade cures" or "boiler patent medicines". Substantial property damage, damage to boiler, and/or serious personal injury may result.
- Continual fresh make-up water will reduce boiler life. Mineral buildup in the heat exchanger reduces heat transfer, overheats the stainless steel heat exchanger, and causes failure. Addition of oxygen from make-up water can cause internal corrosion in system components. Leaks in the boiler or piping must be repaired at once.

**NOTE:** DO NOT add cold make up water to the system when the boiler is hot. Thermal shock can potentially cause cracks in the heat exchanger. Such damage IS NOT covered by warranty.

#### E. Freeze Protection

**NOTE:** Consider piping and installation when determining boiler location.

<b>CAUTION</b>
Failure of the boiler due to freeze related damage IS NOT covered by product warranty.
 <b>WARNING</b>
NEVER use any toxic chemical, including automotive, standard glycol antifreeze, or ethylene glycol made for hydronic (non-potable) systems. These chemicals can attack gaskets and seals in water systems, are poisonous if consumed, and can cause personal injury or death.

#### Part 2 - Before You Start

<b>NOTICE</b>
<b>UNCRATING THE BOILER</b> - Any claims for damage or shortage in shipment must be filed immediately against the transportation company by the consignee.

Remove all sides of the shipping crate of the boiler.

#### A. What's in the Box

Components (and Part #) included with the boiler:

- Temperature and Pressure Gauge (7500P-098)
- Pressure Relief Valve (EFT-55/80/110/155/199 - 7250P-080, EFT-285/399 - 7350P-066)
- Wall Mount Bracket (EFT-55/80/110 - 7600P-021, EFT-155/199/285 - 7600P-121, EFT-399 - 7600P-221)
- Indirect Sensor (7250P-325)
- Outdoor Sensor (7250P-319)

- Intake PVC Tee with Screens
- Exhaust PVC Coupling with Screens
- Installation Manual and Warranty
- CSD-1 Form
- H-2 Data Sheet
- NG to LP Conversion Kit (Included with NG Models)

## B. How the Boiler Operates

Elite FT® condensing technology intelligently delivers hydronic heating while maximizing efficiency. Outlined below are the features of the system and how they operate:

### Stainless Steel Heat Exchanger

The highly efficient stainless steel heat exchanger is designed to extract all available heat from the supply line before it is exhausted.

### Modulating Combustion System

The combustion system modulates the output of the burner during operation to match system demand and achieve the control set point while in operation. The set point can change by internal or external signals to enhance the overall performance of the system.

### Control

The integrated control system monitors the system and regulates fan speed to control boiler output. This allows the boiler to deliver only the amount of heat energy required and nothing more.

The control can be set to monitor outdoor temperature through an outdoor sensor to regulate boiler set point. The system can be further enhanced by installing an indirect water heater to provide domestic hot water.

The control can regulate the output of multiple boilers through its cascade system function. The cascade system is capable of connecting up to eight boilers together in such a way that they function as one boiler system. This allows for greater turn down ratios and provides systematic control of the multiple boilers in an installation to minimize downtime and maximize efficiency.

The cascade system works by establishing one boiler as the master and the other connected boilers as followers. The master boiler requires a sensor to provide feedback on set point temperature in order to adjust heating input from the connected boilers. Each cascaded boiler will have its own pump to provide maximum flow and control heat exchanger flow rate.

### Text Display and Operational LED Light Indicators

The display allows the user to change system parameters and monitor system outputs.

### Gas Valve

Senses suction from the blower, allowing gas to flow only if powered and combustion air is flowing.

### All Metal Integrated Venturi

Controls air and gas flow into the burner.

### Burner

The high grade stainless steel burner uses premixed air and gas to provide a wide range of firing rates.

### Spark Ignition

The burner is ignited by applying high voltage through the system spark electrode. The spark from the electrode ignites mixed gas off of the burner.

### Supply Water Temperature Sensor

This sensor monitors the boiler outlet water temperature

(System Supply). The control adjusts boiler firing rate so the supply temperature will match the boiler set point.

### Return Water Temperature Sensor

This sensor monitors boiler return water temperature (System Return).

### Flue Sensor

Monitors flue temperature and adjusts firing rate.

### Temperature and Pressure Gauge

Allows the user to monitor system temperature and pressure.

### Electrical field connections with terminal strips

The electrical cover allows easy access to the clearly marked line voltage and low voltage terminal strips to facilitate wiring the boiler.

### Condensate Collection System

This boiler is a high efficiency appliance and will produce condensate. The condensate collection system has a float switch which monitors condensate level and prevents condensate from backing up into the combustion system. Inside the collection system is a built in trap which seals the combustion system from the connected drain. This condensate should be neutralized to avoid damage to the drainage system or piping.

### Outdoor Sensor

Monitors outdoor temperature and adjusts unit set point to provide greater efficiency.

### 0-10 Volt Input

Allows the installer to connect a BMS (Building Management System) to control the boiler.

### Condensate Flue Check System

The check system prevents heat exchanger exhaust from backing up into the cabinet.

### Pump Service Mode

Allows manual operation of pumps to commission system and check pump operation.

### The Vision II System (Optional)

Allows the user to supply mixed temperatures in up to eight zones. The Vision II system controls the temperature to each zone by employing three way mixing valves. The Vision II also controls the output temperature of the boiler to assure accurate temperature delivery to all connected zones.

## C. Optional Equipment

Optional equipment available from HTP (and Part #):

- System Sensor (7250P-324)
- Indirect Sensor (7250P-325)
- 3" PVC Concentric Vent Kit (KGAVT0601CVT)
- 3" Stainless Steel Vent Termination Kit (V1000)
- 4" Stainless Steel Vent Termination Kit (V2000)
- 6" Stainless Steel Vent Termination Kit (V3000)
- 3" Polypro Vent Kit (8400P-001)
- 3" Polypro Pipe  
(33' length # 8400P-002, 49.5' length # 8400P-003)
- UL 353 Compliant Low Water Cut-Off Interface Kit with Manual Reset (EFT-55/80/110 - 7600P-104, All other Models - 7600P-990)
- Manual Reset High Limit (7450P-217)
- Alarm System (to monitor any failure) (7350P-602)
- PC Connection Kit (7250P-320)
- Condensate Neutralizer (EFT-55 - 285 - 7450P-212, EFT-399 - 7350P-611)
- Condensate Removal Pump (554200)
- Flow Switch Kit (7450P-213)

- Vision II (7250P-322)

**NOTE:** When using an optional system sensor, pipe insulation must be wrapped around it to improve temperature measurement accuracy and increase overall system efficiency.

### Part 3 - Prepare the Boiler

Remove all sides of the shipping crate, and the wooden block that holds the boiler in place during shipping. Slide the boiler from the mounting bracket, which is affixed to the skid (Figure 1 and 2). Remove the mounting bracket from the crate (Figure 1). Take care to place the boiler in a safe location prior to installation to prevent damage to the mechanical connections.

#### CAUTION

**COLD WEATHER HANDLING** - If the boiler has been stored in a very cold location (BELOW 0°F) before installation, handle with care until the components come to room temperature. Failure to do so could result in damage to the boiler.

Carefully consider installation when determining boiler location. Please read the entire manual before attempting installation. Failure to properly take factors such as boiler venting, piping, condensate removal, and wiring into account before installation could result in wasted time, money, and possible property damage and personal injury.



Figure 1 - Pallet with Mounting Bracket Affixed



Figure 2 - Boiler Mounted to Mounting Bracket on Pallet

#### A. Locating the Boiler

#### WARNING

This boiler is certified for indoor use only. **DO NOT INSTALL OUTDOORS.** Outdoor installations ARE NOT covered by warranty. Failure to install the boiler indoors could result in property damage, severe personal injury, or death.

#### WARNING

Incorrect ambient conditions can lead to damage to the heating system and put safe operation at risk. Ensure that the installation location adheres to the information included in this manual. Failure to do so could result in property damage, serious personal injury, or death. Failure of boiler or components due to incorrect operating conditions IS NOT covered by product warranty.

1. Installation Area (Mechanical Room) Operating Conditions
  - Ensure ambient temperatures are higher than 32°F / 0°C and lower than 104°F / 40°C
  - Prevent the air from becoming contaminated by the products, places, and conditions listed in this manual
  - Avoid continuously high levels of humidity
  - Never close existing ventilation openings
  - Ensure a minimum 1" clearance around hot water and exhaust vent pipes
  - NOTE: To prevent condensing in the fan, it is recommended to avoid prolonged exposure to temperatures below 45°F

#### WARNING

This boiler has a condensate disposal system that may freeze if exposed to sustained temperatures below 32°F. Precautions should be taken to protect the condensate trap and drain lines from sustained freezing conditions. Failure to take precautions could result in property damage, severe personal injury, or death.

2. Check for nearby connections to:
  - System water piping
  - Venting connections
  - Gas supply piping
  - Electrical power
  - Condensate drain
3. Check area around boiler. Remove any combustible materials, gasoline, and other flammable liquids.

#### WARNING

Failure to keep the boiler area clear and free of combustible materials, liquids, and vapors can result in substantial property damage, severe personal injury, or death.

#### CAUTION

The service life of the boiler's exposed metallic surfaces, such as the casing, as well as internal surfaces, such as the heat exchanger, are directly influenced by proximity to damp and salty marine environments. In such areas higher concentration levels of chlorides from sea spray coupled with relative humidity can lead to degradation of boiler components. In these environments, boilers must not be installed using direct vent systems which draw outdoor air for combustion. Such boilers must be installed using room air for combustion. Indoor air will have a much lower relative humidity, and hence potential corrosion will be minimized.



**CAUTION**

High heat sources (generating heat 100°F / 37°C or greater, such as boiler flue pipes, space heaters, etc.) may damage plastic components of the boiler as well as plastic vent pipe materials. Such damages ARE NOT covered by warranty. It is recommended to keep a minimum clearance of 8" from high heat sources. Observe heat source manufacturer instructions, as well as local, state, provincial, and national codes, laws, regulations, and ordinances when installing this boiler and related components near high heat sources.

Locate the boiler where any leakage from the relief valve, related piping, tank, or connections will not result in damage to surrounding areas or lower floors of the building. The boiler should be located near a floor drain or installed in a drain pan. Leakage damages ARE NOT covered by warranty.

Failure of the boiler or components due to incorrect operating conditions IS NOT covered by product warranty.

4. Gas control system components must be protected from dripping water during operation and service.
5. If the boiler is to replace an existing boiler, check for and correct any existing system problems, such as:
  - System leaks
  - Location that could cause the system and boiler to freeze and leak
  - Incorrectly sized expansion tank

6. Clean and flush system when reinstalling a boiler.

**NOTE:** When installing in a zero clearance location, it may not be possible to read or view some product labeling. It is recommended to make note of the boiler model and serial number.

**B. Structure**

**WARNING**

Assure that the structure of the installation location is sufficient to support the full installed weight of the boiler, including water content of the heat exchanger and related piping. Failure to ensure the structure of the installation location is structurally sound before installation of the boiler can result in structural failure, substantial property damage, severe personal injury, or death.

**C. Leveling**

**CAUTION**

In order for the condensate to properly flow out of the collection system, the area where you locate the boiler must be level. Location must also fully support the weight of the filled boiler.

**D. Clearances for Service Access**

**NOTE:** If you do not provide the minimum clearances shown in Figure 3 it might not be possible to service the boiler without removing it from the space.

- Minimum Clearances from Combustible Materials**
- Hot water pipes - at least 1" from combustible materials
  - Exhaust vent pipe - at least 1" from combustible materials

**WARNING**

Do not mount the boiler to a hollow wall. Mount to the studs only.

Use extreme care not to drop the boiler or cause bodily injury while lifting or mounting the boiler onto the wall mount bracket.

Failure to follow these instructions could result in property damage, severe personal injury, or death.

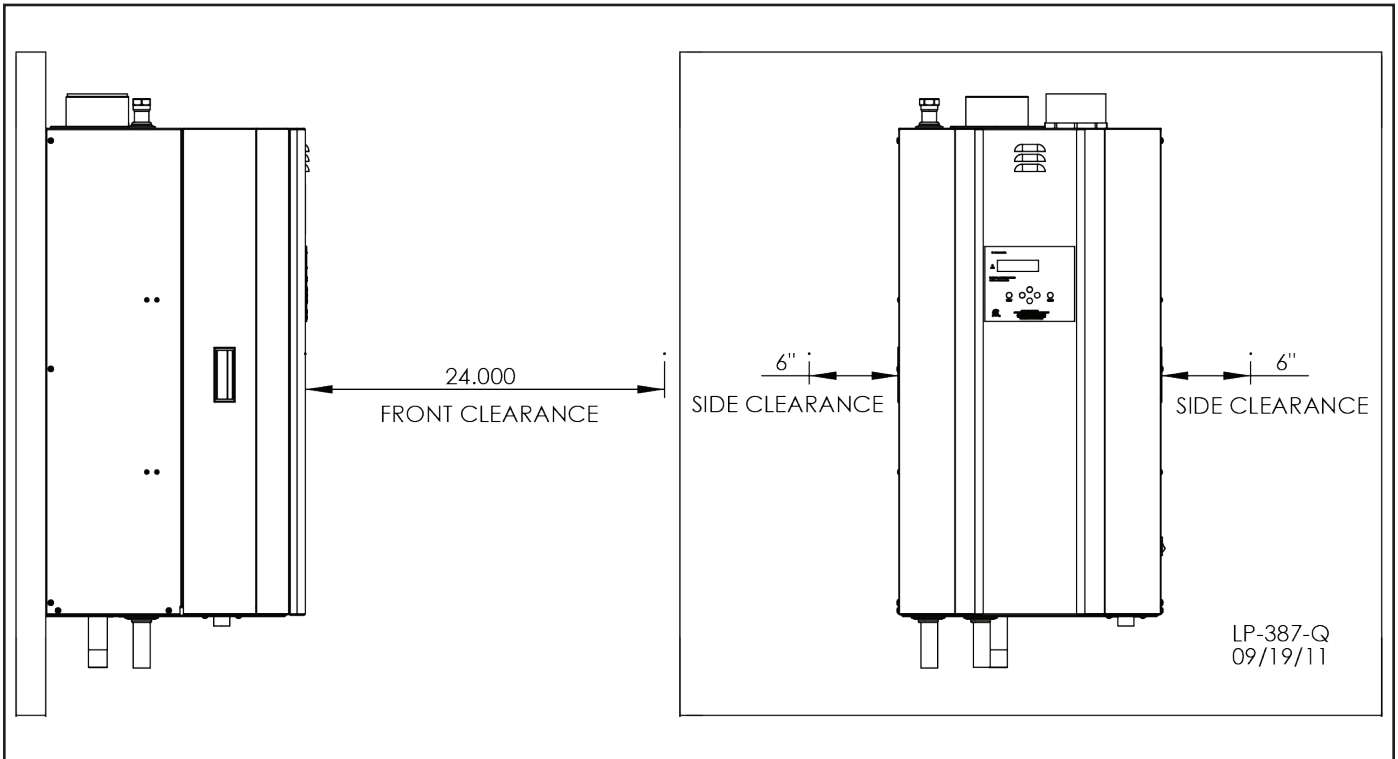

Figure 3 - Recommended Service Clearances

### CAUTION

Always take future maintenance into consideration when locating the boiler. If the boiler is located in an installation location with limited clearances, it may be necessary to remove the boiler from the space to perform maintenance. Failure to consider maintenance when determining installation location could result in property damage.

### WARNING

The space must be provided with combustion / ventilation air openings correctly sized for all other appliances located in the same space as the boiler. The boiler cover must be securely fastened to prevent the boiler from drawing air from the boiler room. This is particularly important if the boiler is in a room with other appliances. Failure to comply with the above warnings could result in substantial property damage, severe personal injury, or death.

### CAUTION

All boilers eventually leak. It is recommended to install a catch pan beneath the boiler. This catch pan should be sized with a maximum depth of 2", and a minimum diameter 2" greater than the diameter of the boiler. The catch pan should empty into an open drain line. This drain line should be 3/4" ID minimum, piped to an open drain. Failure to follow these instructions could result in property damage. Such damages ARE NOT covered by product warranty.

#### E. Wall Mounting Considerations

These boilers are wall mounted. Use only the wall mounting instructions included in this manual.

Ensure the wall that the boiler is intended to be mounted on is comprised of cement, brick, block, or wooden studs spaced 16" apart from center. Ensure the wall is capable of supporting at least 250 lbs (115 kg) for EFT-55 – 110 models, 300 lbs (136 kg) for EFT-155 – 285 models, and 500 lbs (227 kg) for EFT-399.

If flooding is possible, elevate the boiler to prevent floodwater from reaching the boiler.

Ensure the boiler is installed in a location that minimizes the risk of water damage due to leaking valves, pumps, unions, etc.

### WARNING

The mounting location must be capable of carrying the weight of the boiler and its related components. If the mounting location cannot support a minimum of 250 lbs. (115 kg), it is recommended to locate the boiler in a mounting location that can support the minimum weight. Failure to comply with the above and properly mount the boiler could result in substantial property damage, severe personal injury, or death.

#### F. Wall Mounting Instructions

### WARNING

This boiler is too heavy for one person to lift. It is highly recommended to install the boiler with two people. Use caution as to not drop the boiler, which could damage the boiler and cause property damage and/or severe personal injury. Verify that the boiler is properly and securely mounted before leaving unsupervised. Failure to comply with the above and properly mount the boiler could result in substantial property damage, severe personal injury, or death.

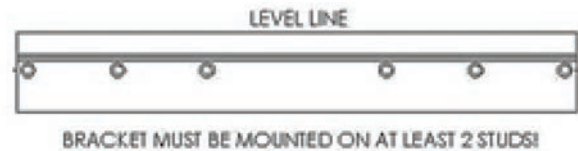

Figure 4 - Wall Mounting Bracket - NOTE: Drawing for Demonstration Purposes Only

### WARNING

This wall mounting system is not seismic rated and should not be applied as such. Failure to comply with the above and properly mount the boiler could result in substantial property damage, severe personal injury, or death.

DO NOT use the bolts included in shipping for wall mounting the boiler. Doing so may result in property damage, serious injury, or death.

#### 1. Mounting to a Wood Studded Wall

a. The building frame (studs) must be 2 X 4 minimum and 16" on center (24" on the EFT-399). If not, you must use 1/2" minimum plywood 24" x 48" with at least fourteen (14) #12 x 3" (3/16" x 3") round head tapping screws to the frame of the building to provide proper support for the boiler. No alternate methods of mounting or fastening (ex. Toggle bolts, hollow wall anchors, or any other fastener) may be used.

b. The provided mounting bracket must be mounted directly to the center of at least 2 studs using standard steel or stainless steel 3/4" x 2 1/2" lag bolts for all models. Be sure the bracket is level and mark the hole location of the bracket height and horizontal stud location. Ensure the marked holes are located in the center of the building frame (studs).

c. For all EFT models, 2 1/2" is the minimum lag bolt length if the bracket is directly on stud. Increase lag bolt length for any materials covering the studs.

d. Predrill pilot holes on the marked stud locations. The pilot holes for bare studs should be 2" deep for all EFT models. See table below for pilot hole diameter by wood type. Increase length for any material covering the stud. Ensure that the predrilled holes are straight and square to the wall. Failure to do so could lead to insufficient support or out of level boiler. See Figure 4.

**NOTE:** Bolt must embed into the wood structure a minimum of 2".

e. Using the predrilled holes, mount the hanger bracket to the building frame (studs) using the appropriately sized standard steel (or stainless) lag bolt. Hang boiler on the wall mounted bracket. Be sure that the bracket is engaged before letting the boiler hang free. Slowly release the weight of the boiler while ensuring that the bracket is properly secured. Verify that the boiler is securely mounted before leaving the boiler unsupervised.

### CAUTION

If the boiler is not installed upright, vertically plumb, and level, improper and unsatisfactory operation may occur, causing excessive condensation build-up, nuisance fault codes, and unnecessary maintenance.

Required Amount of Bolts for Wall-Mounting the Boiler	
Model	Amount of Bolts
EFT-55 - 110	2
EFT-155 - 285	4
EFT-399	6
Pilot Hole Size by Wood Type	
Type	Drill Bit Size
Soft	3/32"
Hard	3/16"

**Table 1 - Bolts Required and Pilot Hole Size for Wall-Mounting the EFT Boiler**

**2. Mounting to a Metal Frame**

a. The provided mounting bracket must be mounted to the center of at least 2 studs using standard steel or stainless steel toggle bolts 3/16" diameter or larger, and at least 2" long for direct mounting on stud for EFT-55 – 110 models, and 3/8" diameter or larger, and at least 2" long for EFT-155 – 399 models for direct mounting on at least 18 gauge studs. Be sure the bracket is level and mark the hole location of the top bracket height and horizontal stud location. Ensure the marked holes are located in the center of the building frame (studs).

b. 2" is the minimum toggle bolt length if the bracket is directly on stud. Increase length for any materials covering the studs.

c. Predrill holes on the marked stud locations. The predrilled holes should be 1/2" in diameter for 3/16" bolts, and 3/4" in diameter for 3/8" bolts, to allow for the collapsed wings of the toggle to slide through. Ensure that the predrilled holes are straight and square to the wall. Failure to do so could lead to insufficient support of out of level boiler. See Figure 4.

d. Using the predrilled holes, mount the hanger bracket to the building frame (studs) with the toggle bolts. Ensure that the bolt toggles are through the stud and expanded catching the inside of the stud. Tighten the toggle bolt until the mounting bracket is secure. Hang boiler on the now wall mounted bracket. Be certain that the bracket is engaged before letting the boiler hang free. Slowly release the weight of the boiler while ensuring the bracket is properly secure. Verify that the boiler is securely mounted before leaving it unsupervised.

**G. Residential Garage, Closet, and Alcove Installations**

<b>CAUTION</b>
Check with your local Authority Having Jurisdiction for requirements when installing boiler in a garage, closet, or alcove. Please read the entire manual before attempting installation. Failure to properly take factors such as boiler venting, piping, condensate removal, and wiring into account before installation could result in wasted time, money, and possible property damage and personal injury.

**Precautions**

If the boiler is located in a residential garage, per ANSI Z223.1:

- Install the boiler burner and ignition devices a minimum of 18" above the floor of the garage. This will ensure the burner and ignition devices are well off the floor.
- Locate or protect the boiler so it cannot be damaged by a moving vehicle.

<b>WARNING</b>
For closet or alcove installations, a two pipe venting system must be used. Failure to follow this warning could result in substantial property damage, severe personal injury, or death.
<b>WARNING</b>
The space must be provided with correctly sized combustion/ventilation air openings for all other boilers located in the space with the boiler. Do not install the boiler in an attic. Failure to comply with these warnings could result in substantial property damage, severe personal injury, or death.

**NOTE:** For installations using room air for combustion, refer to the boiler venting section, this manual.

**H. Exhaust Vent and Intake Pipe**

The boiler is rated ANSI Z21.13 Category IV (pressurized vent, likely to form condensate in the vent) and requires a special vent system designed for pressurized venting.

**NOTE: The venting options described here (and further detailed in the Venting section, this manual) are the lone venting options approved for this boiler. Failure to vent the boiler in accordance with the provided venting instructions will void the warranty.**

<b>DANGER</b>
Failure to vent the boiler properly will result in serious personal injury or death.
<b>WARNING</b>
Do not attempt to vent this boiler by any means other than those described in this manual. Doing so will void the warranty and may result in severe personal injury or death.
Vents must be properly supported. Boiler exhaust and intake connections are not designed to carry heavy weight. Vent support brackets must be within 1' of the boiler and the balance at 4' intervals. Boiler must be readily accessible for visual inspection for first 3' from the boiler. Failure to properly support vents could result in property damage, severe personal injury, or death.
The exhaust discharged by this boiler may be very hot. Avoid touching or other direct contact with the exhaust gases of the vent termination assembly. Doing so could result in severe personal injury or death.

**1. Direct Vent of Exhaust and Intake**

If installing a direct vent option, combustion air must be drawn from the outdoors directly into the boiler intake and exhaust must terminate outdoors. There are three basic direct vent options detailed in this manual: 1. Side Wall Venting, 2. Roof Venting, and 3. Unbalanced Venting.

Be sure to locate the boiler such that the exhaust vent and intake piping can be routed through the building and properly terminated. Different vent terminals can be used to simplify and eliminate multiple penetrations in the building structure (see Optional Equipment in Venting Section). The exhaust vent and intake piping lengths, routing, and termination methods must all comply with the methods and limits given in the Venting Section, this manual.

When installing a combustion air intake from outdoors, care must be taken to utilize uncontaminated combustion air. **To prevent combustion air contamination, see Table 2.**

<b>⚠ WARNING</b>	
<b>Breathing Hazard - Carbon Monoxide Gas</b>	
	<ul style="list-style-type: none"> <li>• Do not operate heater if flood damaged.</li> <li>• Install vent system in accordance with local codes and manufacturers installation instructions.</li> <li>• Do not obstruct heater air intake or exhaust. Support all vent piping per manufacturers installation instructions.</li> <li>• Do not place chemical vapor emitting products near unit.</li> <li>• According to NFPA 720, carbon monoxide detectors should be installed outside each sleeping area.</li> <li>• Never operate the heater unless it is vented to the outdoors.</li> <li>• Analyze the entire vent system to make sure that condensate will not become trapped in a section of vent pipe and therefore reduce the open cross sectional area of the vent.</li> </ul> <p style="text-align: right; font-size: small;">LP-304-FR</p>
<b>Breathing carbon monoxide can cause brain damage or death. Always read and understand instruction manual.</b>	

## 2. Indoor Combustion Air in Confined or Unconfined Space

This boiler requires fresh, uncontaminated air for safe operation and must be installed in a mechanical room where there is adequate combustion and ventilating air. **NOTE: To prevent combustion air contamination, see Table 2.**

Combustion air from the indoor space can be used if the space has adequate area or when air is provided through a duct or louver to supply sufficient combustion air based on the boiler input. Never obstruct the supply of combustion air to the boiler. If the boiler is installed in areas where indoor air is contaminated (see Table 2) it is imperative that the boiler be installed as direct vent so that all combustion air is taken directly from the outdoors into the boiler intake connection.

**Unconfined space** is space with volume greater than 50 cubic feet per 1,000 BTU/hr (4.8 cubic meters per kW) of the total input rating of all fuel-burning appliances installed in that space. Rooms connected directly to this space through openings not furnished with doors are considered part of the space. See Venting Section for details.

**Confined space** is space with volume less than 50 cubic feet per 1,000 BTU/hr (4.8 cubic meters per kW) of the total input rating of all fuel-burning appliances installed in that space. Rooms connected directly to this space through openings not furnished with doors are considered part of the space.

When drawing combustion air from inside a conventionally constructed building to a confined space, such space should be provided with two permanent openings: one located 6" (15 cm) below the space ceiling, the other 6" (15cm) above the space floor. Each opening should have a free area of one square inch per 1,000 BTU/hr (22cm<sup>2</sup>/kW) of the total input of all appliances in the space, but not less than 100 square inches (645cm<sup>2</sup>).

If the confined space is within a building of tight construction, air for combustion must be obtained from the outdoors as outlined in the Venting section of this manual.

<b>CAUTION</b>
When drawing combustion air from the outside into the mechanical room, care must be taken to provide adequate freeze protection.

<b>⚠ WARNING</b>
Failure to provide an adequate supply of fresh combustion air can cause poisonous flue gases to enter the living space, resulting in severe personal injury or death. To prevent combustion air contamination, see Table 2.

## I. Prevent Combustion Air Contamination

Install intake air piping for the boiler as described in the Venting Section, this manual. Do not terminate exhaust in locations that can allow contamination of intake air.

<b>⚠ WARNING</b>
Ensure that the intake air will not contain any of the contaminants in Table 2. Contaminated air will damage the boiler, resulting in possible substantial property damage, severe personal injury, or death. For example, do not pipe intake air near a swimming pool or laundry facilities. These areas always contain contaminants.

## J. Removing a Boiler from a Common Vent System

<b>⚠ DANGER</b>
Do not install the boiler into a common vent with any other appliance. This will cause flue gas spillage or appliance malfunction, resulting in possible substantial property damage, severe personal injury, or death.

<b>⚠ WARNING</b>
Failure to follow all instructions can result in flue gas spillage and carbon monoxide emissions, causing severe personal injury or death.

When removing an existing boiler, follow the steps below.

1. Seal any unused openings in the common venting system.
2. Visually inspect the venting system for proper size and horizontal pitch to determine if there is blockage, leakage, corrosion, or other deficiencies that could cause an unsafe condition.
3. If practical, close all building doors, windows, and doors between the space in which the boiler remains connected to the common venting system and other spaces in the building. Turn on clothes dryers and any appliances not connected to the common venting system. Turn on any exhaust fans, such as range hoods and bathroom exhausts, at maximum speed. Do not operate a summer exhaust fan. Close all fireplace dampers.
4. Place in operation the appliance being inspected. Follow the lighting instructions. Adjust the thermostat so the appliance will operate continuously.
5. Test for spillage at the draft hood relief opening after 5 minutes of main burner operation. Use the flame of a match or candle or smoke from a cigarette.
6. After it has been determined that each appliance remaining connected to the common venting system properly vents when tested as outlined, return doors, windows, exhaust fans, fireplace dampers, and any other gas burning appliances to their previous condition of use.
7. Any improper operation of the common venting system should be corrected to conform to the National Fuel Gas Code, ANSI Z223.1. When resizing any portion of the common venting system, the system should approach the minimum size as determined using the appropriate tables in Appendix

G of ANSI Z223.1.

Products to Avoid	Areas Likely to Have Contaminants
Spray cans containing fluorocarbons	Dry cleaning / laundry areas and establishments
Permanent wave solutions	Swimming pools
Chlorinated waxes / cleaners	Metal fabrication plants
Chlorine-based swimming pool chemicals	Beauty shops
Calcium chloride used for thawing	Refrigeration repair shops
Sodium chloride used for water softening	Photo processing plants
Refrigerant leaks	Auto body shops
Paint or varnish removers	Plastic manufacturing plants
Hydrochloric or Muriatic acid	Furniture refinishing areas and establishments
Cements and glues	New building construction
Antistatic fabric softeners used in clothes dryers	Remodeling areas
Chlorine-type bleaches, laundry detergents, and cleaning solvents	Garages and workshops
Adhesives used to fasten building products	

Table 2 - Products and Areas Likely to Have Contaminants

**NOTE: DAMAGE TO THE BOILER CAUSED BY EXPOSURE TO CORROSIVE VAPORS IS NOT COVERED BY WARRANTY.** (Refer to the limited warranty for complete terms and conditions.)

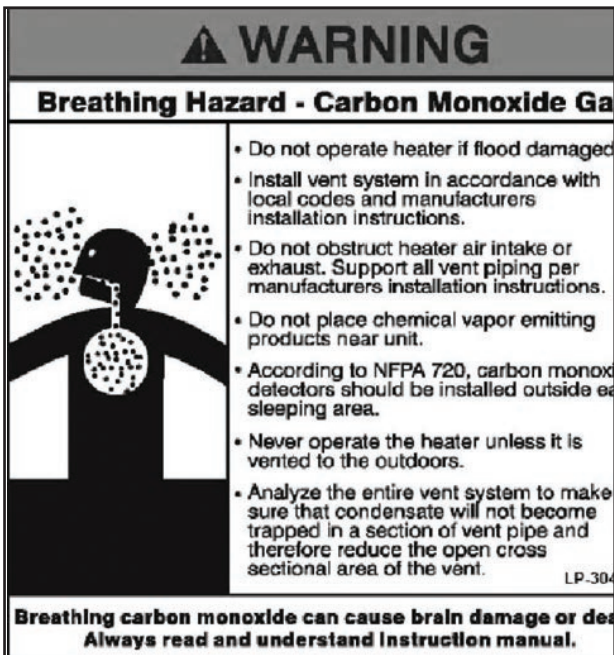

Figure 5 - CO Warning Label

**I. Water Chemistry Requirements\***

<b>CAUTION</b>
Chemical imbalance of the water supply may affect efficiency and cause severe damage to the boiler and associated equipment. HTP recommends having water quality professionally analyzed to determine whether it is necessary to install a water softener. It is important that the water chemistry on both the domestic hot water and central heating sides are checked before installing the boiler, as water quality will affect the reliability of the system. Failure of a boiler due to lime scale build-up, low pH, or other chemical imbalance IS NOT covered by the warranty.

- Sodium less than 20 mGL
- Water pH between 6.0 and 8.0
  - Maintain water pH between 6.0 and 8.0. Check with litmus paper or have it chemically analyzed by water treatment company.
  - If the pH differs from above, consult local water treatment for treatment needed.
- Hardness less than 7 grains
  - Consult local water treatment companies for unusually hard water areas (above 7 grains hardness).
- Chlorine concentration less than 100 ppm
  - Using chlorinated fresh water should be acceptable as levels are typically less than 5 ppm.
  - Do not connect the boiler to directly heat swimming pool or spa water.
  - Do not fill boiler or operate with water containing chlorine in excess of 100 ppm.

\*NOTE: It is recommended to clean the heat exchanger at least once a year to prevent lime scale buildup. To clean the heat exchanger, follow the maintenance procedure in this manual.

**Hardness:** Less than 7 grains

**Chloride levels:** Less than 100 ppm

**pH levels:** 6 - 8

**Conductivity:** Less than 400 uS/cm at 25°C

**Sodium:** Less than 20 mGL

**Copper:** Less than 0.1 mg/:

**Iron:** Less than 0.5 mg/L

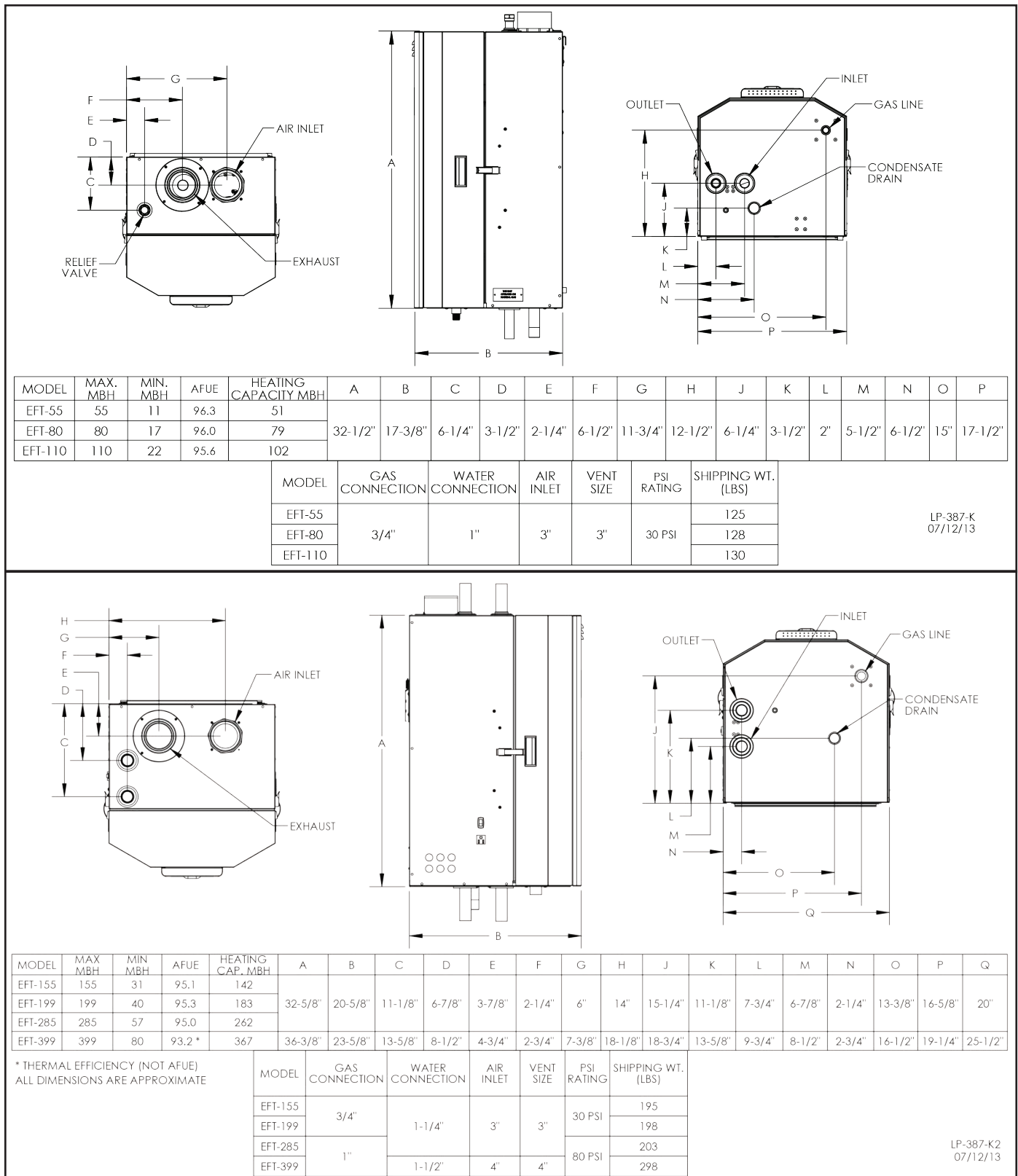

Figure 6 - Boiler Dimensions - NOTE: All Dimensions Are Approximate

**Part 4 - Piping**

**⚠ WARNING**

Failure to follow the instructions in this section WILL VOID the warranty and may result in property damage, severe personal injury, or death.

The National Standard Plumbing Code, the National Plumbing Code of Canada, and the Uniform Plumbing Code limit heat transfer fluid pressure to less than the minimum working pressure of the potable water system up to 30 PSI maximum. In addition, the heat transfer fluid must be water or another non-toxic fluid having a toxicity of Class 1, as listed in Clinical Toxicology of Commercial Products, 5th Edition. Failure to follow this warning could result in property damage, severe personal injury, or death.

**CAUTION**

Dielectric unions or galvanized steel fittings must not be used in a system with this boiler. Doing so WILL VOID the warranty. Use only copper, brass, or stainless steel fittings. Teflon thread sealant must be used on all connections.

Plumbing of this product should only be done by a qualified, licensed plumber in accordance with all local plumbing codes. The boiler may be connected to an indirect water heater to supply domestic hot water. HTP offers indirect water heaters in a wide range of gallon sizes in either stainless steel or glass-lined construction.

**A. General Plumbing Information**

**CAUTION**

The building piping system must meet or exceed the the piping requirements in this manual.

Use two wrenches when tightening water piping at boiler. Use one wrench to prevent the boiler return or supply line from turning. Failure to prevent piping connections from turning could cause damage to boiler components.

The control module uses temperature sensors to provide both high limit protection and modulating temperature control. The control module may also provide low water protection (through the addition of an optional kit) by sensing the water level in the heat exchanger. An optional flow switch may be installed on the supply of the system to activate the boiler when there is enough flow. Some codes/jurisdictions may require additional external controls.

**NOTE:** The addition of a high temperature limiting device is important if the boiler is to be connected to a domestic hot water system.

**B. Relief Valve**

Connect discharge piping to a safe disposal location following the guidelines below.

**⚠ WARNING**

To avoid water damage or scalding due to relief valve operation:

- Discharge line must be connected to relief valve outlet and run to a safe place of disposal. Terminate the discharge line in a manner that will prevent possibility of severe burns or property damage should the relief

- valve discharge.
- Discharge line must be as short as possible and the same size as the valve discharge connection throughout its entire length.
- Discharge line must pitch downward from the valve and terminate at least 6" above the floor drain, making discharge clearly visible.
- The discharge line shall terminate plain, not threaded, with a material serviceable for temperatures of 375°F or greater.
- Do not pipe discharge to any location where freezing could occur.
- No valve may be installed between the relief valve and boiler or in the discharge line. Do not plug or place any obstruction in the discharge line.
- Test the operation of the relief valve after filling and pressurizing the system by lifting the lever. Make sure the valve discharges freely. If the valve fails to operate correctly, immediately replace with a new properly rated relief valve.
- Test T&P valve at least once annually to ensure the waterway is clear. If valve does not operate, turn the boiler "off" and call a plumber immediately.
- Take care whenever operating relief valve to avoid scalding injury or property damage.

**FAILURE TO COMPLY WITH THE ABOVE GUIDELINES COULD RESULT IN FAILURE OF RELIEF VALVE OPERATION, RESULTING IN POSSIBILITY OF SUBSTANTIAL PROPERTY DAMAGE, SEVERE PERSONAL INJURY, OR DEATH.**

**⚠ WARNING**

Do not thread a cap or plug into the relief valve or relief valve line under any circumstances! Explosion and property damage, serious injury, or death may result.

**RE-INSPECTION OF T&P RELIEF VALVES: T&P valves should be inspected AT LEAST ONCE EVERY THREE YEARS, and replaced if necessary,** by a licensed plumbing contractor or qualified service technician to ensure that the product has not been affected by corrosive water conditions and to ensure that the valve and discharge line have not been altered or tampered with illegally. Certain naturally occurring conditions may corrode the valve and its components over time, rendering the valve inoperative. Such conditions can only be detected if the valve and its components are physically removed and inspected. **Do not attempt to conduct an inspection on your own.** Contact your plumbing contractor for a re-inspection to assure continued safety.

**FAILURE TO RE-INSPECT THE T&P VALVE AS DIRECTED COULD RESULT IN UNSAFE TEMPERATURE AND/OR PRESSURE BUILD-UP WHICH CAN RESULT IN PROPERTY DAMAGE, SERIOUS PERSONAL INJURY, OR DEATH.**

**C. Backflow Preventer**

Use a backflow preventer specifically designed for hydronic boiler installations. This valve should be installed on the cold water fill supply line per local codes.

**D. Potable Expansion Tank Expansion Tank and Make-Up Water**

1. Ensure that the expansion tank is sized to correctly handle boiler and system water volume and temperature.

<b>WARNING</b>	
Expansion tanks must be sized according to total system volume. This includes all length of pipe, all fixtures, boilers, etc. Failure to properly size for system expansion could result in wasted time, money, possible property damage, serious injury, or death.	
<b>CAUTION</b>	
Undersized expansion tanks cause system water to be lost from the relief valve, causing make-up water to be added. Eventual boiler failure can result due to excessive make-up water addition. <b>SUCH FAILURE IS NOT COVERED BY WARRANTY.</b>	
<b>DO NOT</b> install automatic air vents on closed type expansion tank systems. Air must remain in the system and return to the tank to provide an air cushion. An automatic air vent would cause air to leave the system, resulting in improper operation of the expansion tank.	

Expansion Tank Sizing	
Model	Heat Exchanger Volume (Gallons)
55 / 80	2.2
110	2.6
155	6.2
199	6.1
285	6.1
399	7.9

Table 3 - Expansion Tank Sizing

2. The expansion tank must be located as shown in Applications, this manual, or following recognized design methods. See expansion tank manufacturer's instructions for details.

3. Connect the expansion tank to the air separator only if the air separator is on the suction side of the circulator. Always install the system fill connection at the same point as the expansion tank connection to the system.

4. Most chilled water systems are piped using a closed type expansion tank.

#### DIAPHRAGM (OR BLADDER) EXPANSION TANK

Always install an automatic air vent on top of the air separator to remove residual air from the system.

#### E. Circulators

<b>CAUTION</b>	
<b>DO NOT</b> use the boiler circulator in any location other than the ones shown in this manual. The boiler circulator location is selected to ensure adequate flow through the boiler. Failure to comply with this caution could result in unreliable performance and nuisance shutdowns from insufficient flow.	

#### Sizing Space Heat System Piping

1. See Applications in this manual. In all diagrams, the space heating system is isolated from the boiler loop by the primary/secondary connection.

2. Size the piping and components in the space heating system using recognized design methods.

#### F. Hydronic Piping with Circulators, Zone Valves, and Multiple Boilers

This boiler is designed to function in a closed loop hydronic

system. It is recommended to install a temperature and pressure gauge (not included with the boiler) to allow the user to monitor system pressure and outlet temperature from the boiler. It is important to note that the boiler has a minimal amount of pressure drop that must be calculated when sizing the circulators. Unless the system has a closed type expansion tank, each boiler installation must have an air elimination device that will remove air from the system.

Install the boiler so the gas ignition system components are protected from water (dripping, spraying, etc.) Allow clearance for basic service of boiler circulator, valves and other components.

Observe the minimum 1" clearance around all uninsulated hot water pipes when openings around pipes are not protected by non-combustible materials.

On a boiler installed above radiation level, some states and local codes require a low water cut off device, which is an optional part available through HTP (Part # 7600P-104 for 55 – 110 models, 7600P-990 for 155 – 399 models). Check with local codes for additional requirements. If the boiler supplies hot water to heating coils in air handler units, flow control valves or other devices must be installed to prevent gravity circulation of boiler water in the coils during the cooling cycle.

Chilled water medium must be piped in parallel with, and isolated from, the boiler. Freeze protection for new or existing systems must use glycol that is specifically formulated for this purpose. Antifreeze must include inhibitors that will prevent the glycol from attacking the metallic system components. Make certain that the system fluid is checked for the correct glycol concentration and inhibitor level. The system should be tested at least once a year and as recommended by the producer of the glycol solution. Allowance should be made for the expansion of the glycol solution in the system piping. Example: 50% by volume glycol solution expands 4.8% in volume for a temperature increase from 32°F to 180°F, while water expands 3% with the same temperature rise.

#### G. Circulator Sizing

In addition, the heat exchanger has a minimum total water volume that must be taken into account when sizing the circulator. Minimum flow rates are listed in the table below.

Minimum Boiler Flow Rates	
Model	Minimum Flow (GPM)
55	3.5
80	5.4
110	7
155	9.7
199	12.5
285	17.9
399	25

Table 4 - Minimum Flow Rates

The heat exchanger has a pressure drop that must be considered in your system design. Refer to Figure 7 for pressure drop through the heat exchanger.



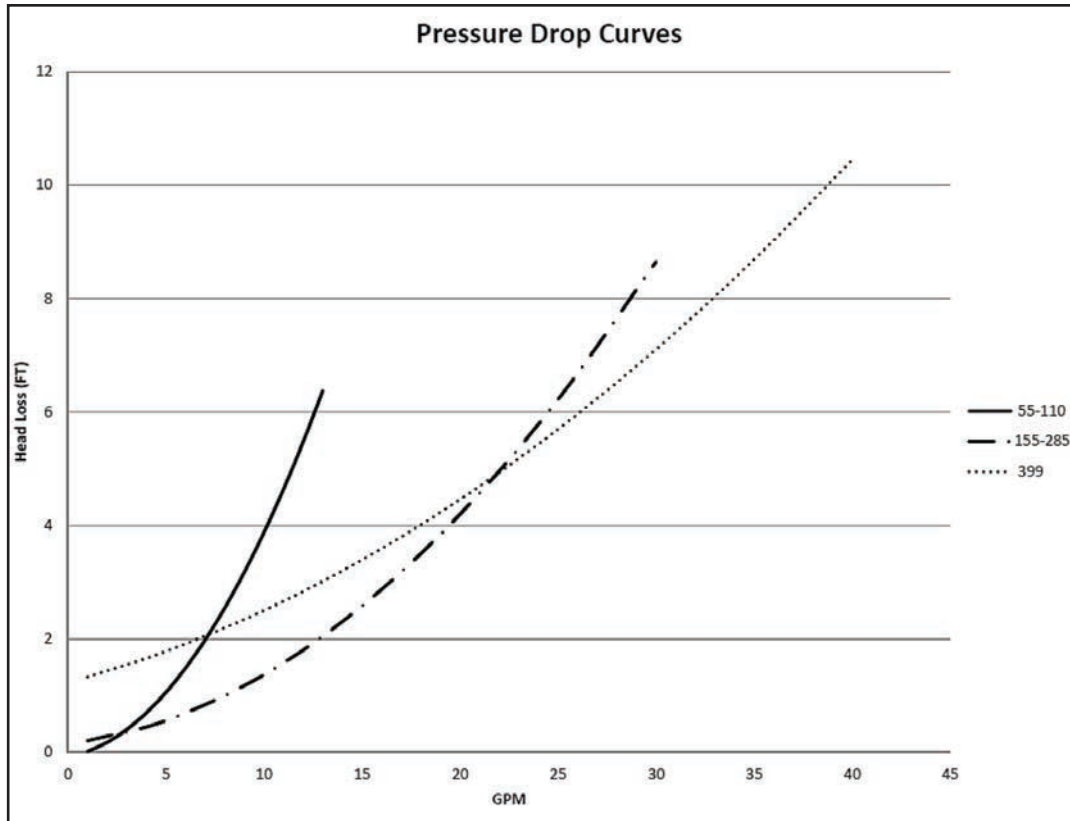

Figure 7 - Boiler Pressure Drop

The chart below represents various system design temperature rise through the boiler along with respective flows and friction loss. This is provided to aid in circulator selection.

System Temperature Rise Chart						
Model	20°Δt		25°Δt		30°Δt	
	Friction Ft	Flow Rate (GPM)	Friction Ft	Flow Rate (GPM)	Friction Ft	Flow Rate (GPM)
55	1.8'	5.3	1.1'	4.2	0.8'	3.5
80	2.8'	8.2	1.9'	6.5	1.3'	5.4
110	4.3'	10.6	2.9'	8.4	1.8'	7
155	2.5'	14.6	1.7'	11.7	1.3'	9.7
199	3.7'	18.7	2.6'	15	1.9'	12.5
285	7'	26.8	4.7'	21.4	3.5'	17.9
399	9.5'	37.5	7.1'	30	5.7'	25

Table 5 - Temperature Rise, Friction Ft and Flow Rate

The chart below represents the combined flow rates and pipe sizes when using multiple boilers to design the manifold system for the primary circuit. To size, simply add up the number of boilers and the required flow rates for the system design temperature. Example: (5) EFT-55 boilers with a design of 20°Δt degree temperature rise with each boiler having an individual flow rate of 5.3 GPM. To correctly size the manifold feeding these (5) boilers you would need a pipe size of 2".

Multiple Boiler Manifold Piping											
Maximum Flow Rate (GPM at 3 Feet per Second)	8	14	19	31.5	45	69	93	120	150	188	271
Schedule 40 Pipe Dia. (In.)	1	1 1/4	1 1/2	2	2 1/2	3	3 1/2	4	4 1/2	5	6

Table 6 - Multiple Boiler Manifold Piping

## H. Check / Control Water Chemistry

**NOTE: Boiler failure due to improper water chemistry is not covered by warranty.**

### Water Chemistry\*

- Sodium less than 20 mGL
- Water pH between 6.0 and 8.0
  - Maintain water pH between 6.0 and 8.0. Check with litmus paper or have it chemically analyzed by water treatment company.
  - If the pH differs from above, consult local water treatment for treatment needed.
- Hardness less than 7 grains
  - Consult local water treatment companies for unusually hard water areas (above 7 grains hardness).
- Chlorine concentration less than 100 ppm
  - Using chlorinated fresh water should be acceptable as levels are typically less than 5 ppm.
  - Do not connect the boiler to directly heat swimming pool or spa water.
  - Do not fill boiler or operate with water containing chlorine in excess of 100 ppm.

**\*NOTE:** It is recommended to clean the heat exchanger at least once a year to prevent lime scale buildup. To clean the heat exchanger, follow the maintenance procedure in this manual.

**Hardness:** Less than 7 grains

**Chloride levels:** Less than 100 ppm

**pH levels:** 6 - 8

**Conductivity:** Less than 400 uS/cm at 25°C

**Sodium:** Less than 20 mGL

**Copper:** Less than 0.1 mg/l

**Iron:** Less than 0.5 mg/L

### Clean system to remove sediment\*

1. You must thoroughly flush the system (without boiler connected) to remove sediment. The high-efficiency heat exchanger can be damaged by buildup or corrosion due to sediment.
2. For zoned systems, flush each zone separately through a purge valve. (If purge valves and isolation valves are not already installed, install them to properly clean the system.)
3. Flush system until water runs clean and you are sure piping is free of sediment.

**\*NOTE:** It is recommended you clean heat exchanger at least once a year to prevent lime scale buildup. Follow the maintenance procedure to clean the heat exchanger in the Maintenance Section of this manual.

### Test/replace freeze protection fluid

1. For systems using freeze protection fluids, follow fluid manufacturer's instructions to verify inhibitor level and that other fluid characteristics are satisfactory.
2. Freeze protection fluid must be replaced periodically due to degradation of inhibitors over time. Follow all fluid manufacturer instructions.

### Piping Components

#### Heating System Piping

System piping **MUST** be sized per technical pipe requirements listed in Tables 6 and 7. Reducing pipe size can restrict flow rate

through the boiler, causing inadvertent short cycling and poor system performance.

#### Check Valves

Field supplied. Check valves are recommended for installation as shown in Applications.

#### Isolation Valves

Field supplied. Full port ball valves are required. Failure to use full port ball valves could result in a restricted flow rate through the boiler.

#### Anti-Scald Mixing Valve

Field supplied. An anti-scald mixing valve is recommended when storing domestic hot water above 115°F.

#### Unions

Field supplied. Recommended for unit serviceability. **DO NOT USE DIELECTRIC UNIONS! ONLY BRASS, COPPER, OR STAINLESS STEEL.**

#### Pressure Relief Valve

Factory supplied on boiler. The pressure relief valve is sized to ASME specifications. Storage tank may require additional relief valves depending on local codes.

Model	Minimum Pipe Sizes
55 / 80 / 110	1" NPT
155 / 199 / 285	1 1/4" NPT
399	1 1/2" NPT

Table 7 - Minimum Pipe Sizes

## I. Plumbing

### CAUTION

This boiler should not be operated as a potable hot water heater. It should not be used as a direct hot water heating device.

**NOTE:** Observe the minimum 1" clearance around all uninsulated hot water pipes when openings around pipes are not protected by non-combustible materials.

Basic steps are listed below, with illustration that will guide you through the installation of the boiler.

1. Connect the system return marked "Boiler Return".
2. Connect the system supply marked "Boiler Supply".
3. Install a purge and balance valve or shut off valve and drain on the system return to purge air out of each zone.
4. Install a back flow preventer on the cold feed make-up water line.
5. Install a pressure reducing valve on the cold feed make-up water line (15 psi nominal on the system return). This boiler has a maximum working pressure of 160 psi. You may order a higher pressure relief valve kit from the factory. Check temperature and pressure gauge when operating. It should read a minimum pressure of 12 psi.
6. Install a circulator as shown in Applications (this manual). Make sure the circulator is properly sized for the system and friction loss.
7. Install an expansion tank on the system supply. Consult the expansion tank manufacturer's instruction manual (see Part 4, Section D for water volume) for specific information relating to expansion tank installation. Size the expansion tank for the required system volume and capacity.
8. Install an air elimination device on the system supply.
9. Install a drain valve at the lowest point of the system. Note:

The boiler cannot be drained completely of water without purging the unit with an air pressure of 15 PSI.

10. The relief valve and temperature and pressure gauge are included in the accessory kit. A discharge line should be installed 6" above the drain in the event of a pressure relief. The pipe size must be the same size as the relief valve outlet. **NEVER BLOCK THE OUTLET OF THE SAFETY RELIEF VALVE.**

#### J. Fill and Purge Heating System

1. Attach the hose to balance and purge hose connector or drain valve and run hose to nearest drain.
2. Close the other side of the balance and purge valve or shut off valve after the drain.
3. Open the first zone balance and purge or drain valve to let water flow out of the hose. If zone valves are used, open the valves one at a time manually. NOTE: You should check zone valve manufacturer's instructions prior to opening valves manually, so as not to damage the zone valve.
4. Manually operate fill valve regulator. When water runs out of the hose, you will see a steady stream without bubbles. Close the balance and purge valve or drain to stop the water from flowing. Disconnect the hose and connect it to next zone to be purged.
5. Repeat this procedure for additional zones (one at a time).

### CAUTION

For installations that incorporate standing iron radiation and systems with manual vents at the high points, follow the previous section and, starting with the nearest manual air vent, open the vent until water flows out. Then close the vent. Repeat the procedure, working your way toward the furthest air vent. It may be necessary to install a basket strainer in an older system where larger amounts of sediment may be present. Annual cleaning of the strainer may be necessary.

Upon completion, make sure that the fill valve and zone valves are in automatic positions. You must also assure the purge and shut off valves are in open positions.

#### K. Glycol Antifreeze Solutions

### WARNING

Use only inhibited propylene glycol solutions which are specially formulated for hydronic systems. Ethylene glycol is toxic and can attack gaskets and seals used in hydronic systems. Glycol mixtures should not exceed 50%. Failure to do so could result in property damage, severe personal injury, or death due to scalds.

- Glycol in hydronic applications should include inhibitors that prevent the glycol from attacking metallic system components. Make certain that the system fluid is checked for the correct glycol concentration and inhibitor level.
- The glycol solution should be tested at least once a year or as recommended by the glycol manufacturer.
- Anti-freeze solutions expand more than water. For example: A 50% by volume solution expands 4.8% in volume for a temperature increase from 32°F to 180°F, while water expands 3% over the same temperature rise. Allowances must be made in system design for expansion.

- A 30% mixture of glycol will result in a BTU output loss of 15% with a 5% increase in head against the system circulator.
- A 50% mixture of glycol will result in a BTU output loss of 30% with a 50% increase in head against the system circulator.

### CAUTION

It is highly recommended that you carefully follow the glycol manufacturer's recommended concentrations, expansion requirements, and maintenance recommendations (pH additive breakdown, inhibitor reduction, etc.) You must carefully calculate the additional friction loss in the system as well as the reduction in heat transfer coefficients.

#### L. Zoning with Zone Valves

1. When zoning with zone valves, connect the boiler to the system as shown in Applications. The primary/secondary piping shown ensures the boiler loop will have sufficient flow. It also avoids applying the high head of the boiler circulator to the zone valves.
2. Connect DHW (domestic hot water) piping to indirect storage water heater as shown in Applications.

#### M. Zoning with Circulators

1. When using circulator zoning, connect the boiler to the system as shown in Applications. NOTE: The boiler circulator cannot be used for a zone. It must only supply the boiler loop.
2. Install a separate circulator for each zone.
3. Connect DHW (domestic hot water) piping to indirect storage water heater as shown in Applications.

#### N. Multiple Boilers

1. Connect multiple boilers as shown in Applications.
2. All piping shown is reverse return to assure balanced flow throughout the connected boilers.
3. Each connected boiler must have its own circulator pump to assure adequate flow.
4. Connect DHW (domestic hot water) piping to indirect storage water heater as shown in Applications.
5. The system flow (secondary loop) must be greater than the boiler's primary loop flow.

O. Applications\*

**CAUTION**

Mixing valves are required for the protection of low temperature loops.

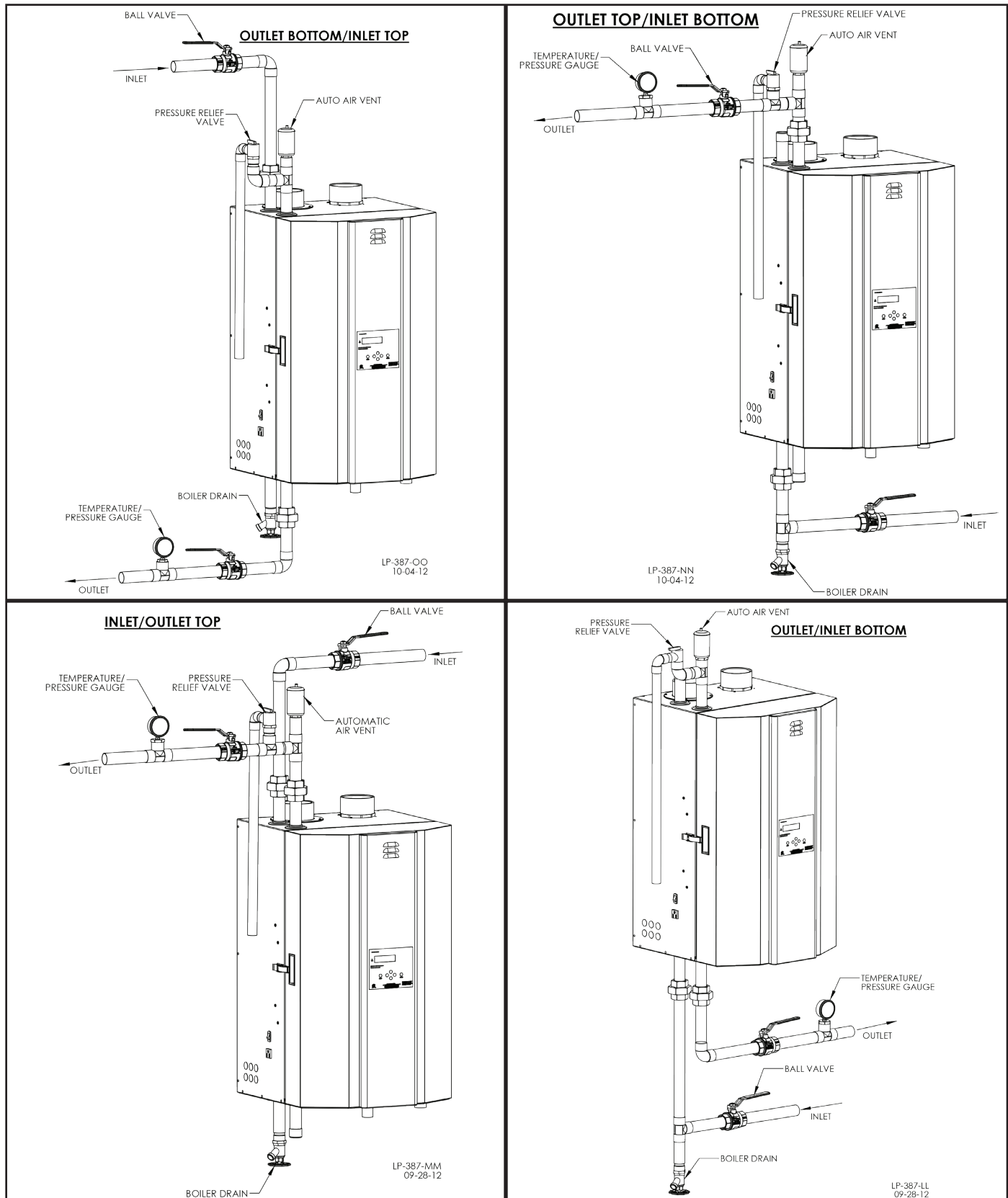



Figure 8 - Near Boiler Piping\* - NOTE: This drawing is meant to show system piping concept only. Installer is responsible for all equipment and detailing required by local codes. \*Top / Bottom Supply / Return Connections Available on 155 / 199 / 285 / and 399 Models ONLY.



NOTE: In piping applications utilizing a single zone, it is recommended that the installer use flow / check valves with weighted seats at or near the appliance to prevent gravity circulation.

# Piping symbol legend



 circulator (w/ isolation flanges)       circulator (w/ integral check valve)



 gate valve       pressure reducing valve



 globe valve       diff. pressure bypass



 ball valve       mixing valve



 swing-check valve       T/P temperature /pressure gauge



 flow-check valve       3-way motorized mixing valve



 spring-loaded check valve       4-way motorized mixing valve



 hose bib / boiler drain       purging valve

 TRV (straight)       pressure relief valve

 TRV angle       backflow preventer

 circuit setter       float-type air vent

 manual 3-way valve       union

 zone valve       DHW temperature sensor

 air separator       Outdoor temperature sensor

 aquastat       heat exchanger

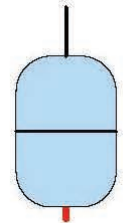
 diaphragm-type expansion tank

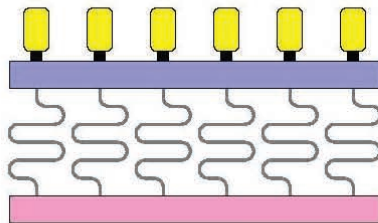

radiant manifold with valve actuators

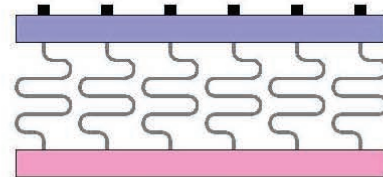

radiant manifold

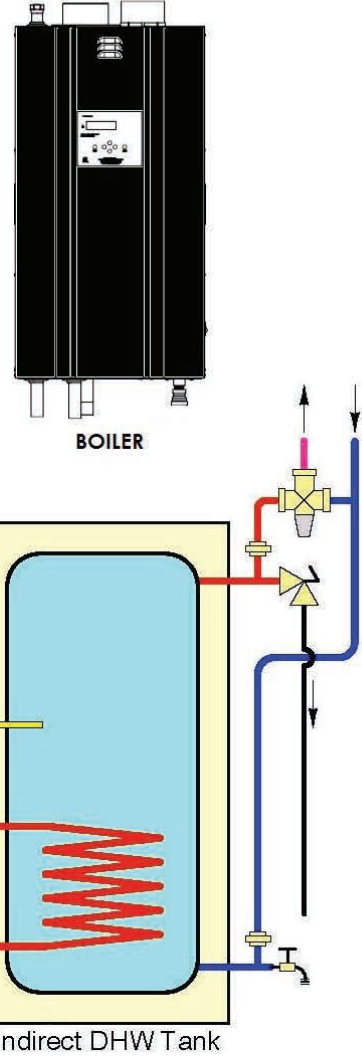

Figure 9 - Piping Symbol Legend

## Standard Piping with Zone Valves & DHW Priority (Single Temp.) Models - 55 & 80 Only

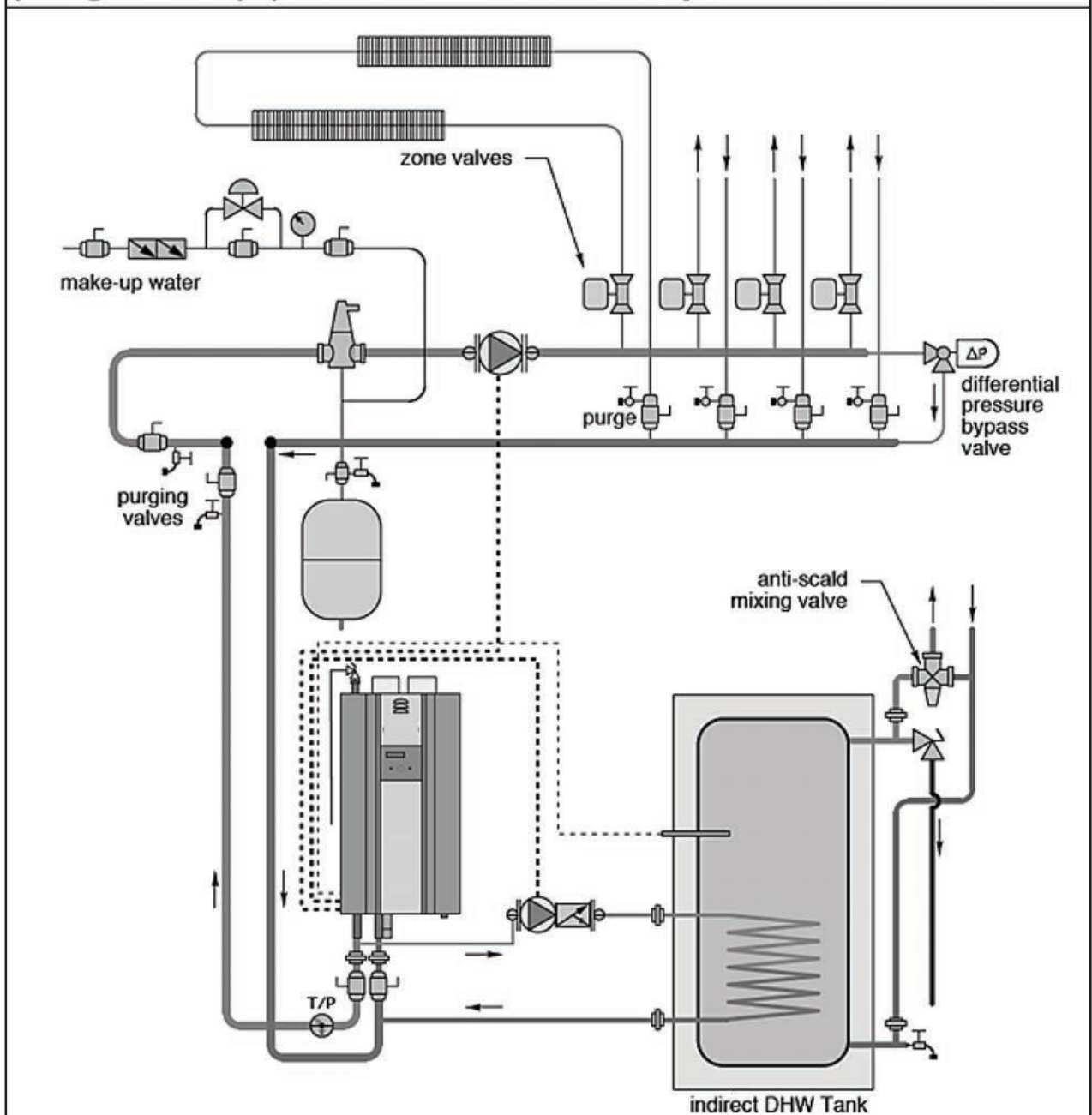

Figure 10 - Standard Piping with Zone Valves and Indirect Priority

### NOTES:

1. This drawing is meant to show system piping concept only. Installer is responsible for all equipment and detailing required by local codes.
2. All closely spaced tees shall be within 4 pipe diameters center to center spacing.
3. A minimum of 6 pipe diameters of straight pipe shall be installed upstream and downstream of all closely spaced tees.
4. The minimum pipe size for connecting an indirect water heater is 1"
5. The minimum pipe size for connecting a 55 or 80 model boiler - 1".
6. Circulators are shown with isolation flanges. The alternative is standard flanges with full port ball valves. Purge valves can be used with circulator flanges as an alternative.
7. A mixing valve is recommended if the DHW temperature is set above the factory setting of 119°F.
8. Piping shown is Standard. VERY IMPORTANT: Minimum flow rates outlined in the manual must be maintained to minimize short cycling.
9. Install a minimum of 12 diameters of straight pipe upstream of all circulators.
10. VERY IMPORTANT - Minimum flow rates outlined in this manual must be maintained through the heat exchanger to minimize short cycling.

### WARNING

The piping will not support the weight of the circulators. Refer to the circulator manufacturer's instructions to properly support the circulator. Failure to comply with these instructions could result in property damage, severe personal injury, or death.

## Standard Piping with Pumps & DHW Priority (Single Temp.) - 55 & 80 Only

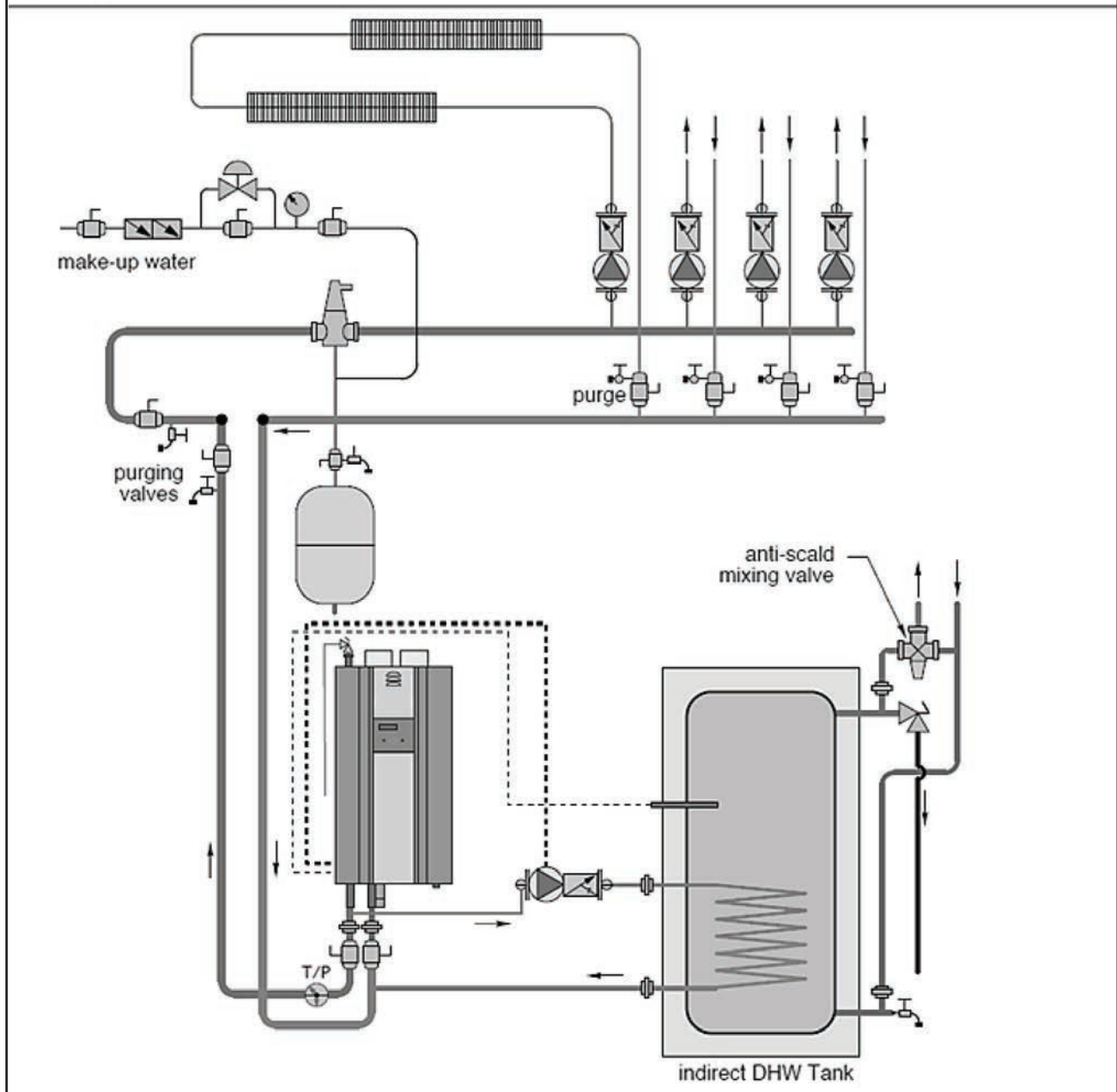

Figure 11 - Standard Piping with Pumps and Indirect Priority

### NOTES:

1. This drawing is meant to show system piping concept only. Installer is responsible for all equipment and detailing required by local codes.
2. All closely spaced tees shall be within 4 pipe diameters center to center spacing.
3. A minimum of 6 pipe diameters of straight pipe shall be installed upstream and downstream of all closely spaced tees.
4. The minimum pipe size for connecting an indirect water heater is 1"
5. The minimum pipe size for connecting a 55 or 80 model boiler - 1".
6. Circulators are shown with isolation flanges. The alternative is standard flanges with full port ball valves. Purge valves can be used with circulator flanges as an alternative.
7. A mixing valve is recommended if the DHW temperature is set above the factory setting of 119°F.
8. Piping shown is Standard.
9. Install a minimum of 12 diameters of straight pipe upstream of all circulators.
10. VERY IMPORTANT – Minimum flow rates outlined in this manual must be maintained through the heat exchanger to minimize short cycling.

### WARNING

The piping will not support the weight of the circulators. Refer to the circulator manufacturer's instructions to properly support the circulator. Failure to comply with these instructions could result in property damage, severe personal injury, or death.

## Primary / Secondary Piping with Zone Valves & DHW Priority (Outdoor Reset) All Models

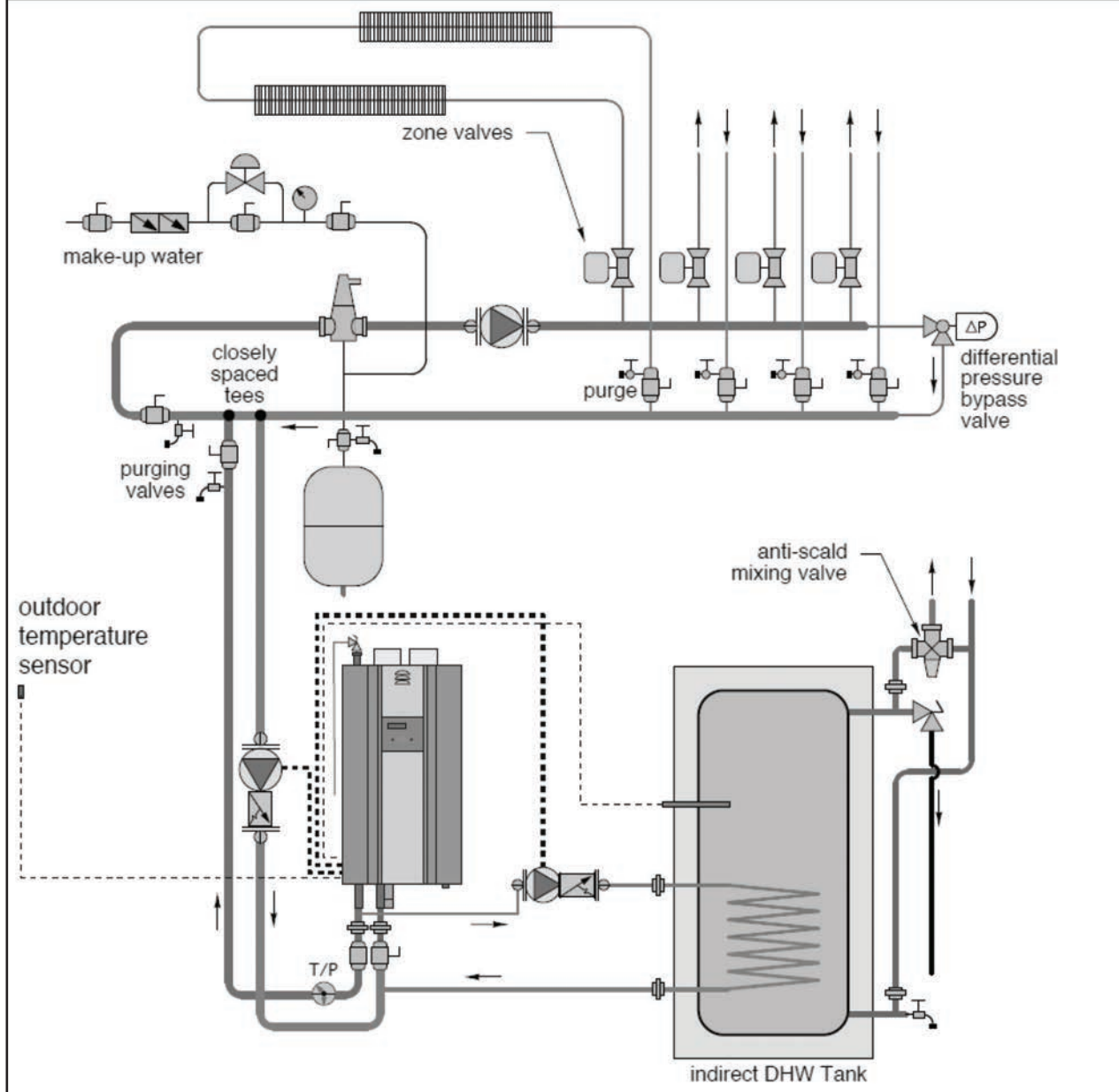

Figure 12 - Primary / Secondary Piping with Zone Valves and Indirect Priority

### NOTES:

1. This drawing is meant to show system piping concept only. Installer is responsible for all equipment and detailing required by local codes.
2. All closely spaced tees shall be within 4 pipe diameters center to center spacing.
3. A minimum of 6 pipe diameters of straight pipe shall be installed upstream and downstream of all closely spaced tees.
4. The minimum pipe size for connecting an indirect water heater is 1"
5. The minimum pipe size for connecting a 55/80/110 - 1", 155/199/285 - 1.25", 399 - 1.5".
6. Circulators are shown with isolation flanges. The alternative is standard flanges with full port ball valves. Purge valves can be used with circulator flanges as an alternative.
7. A mixing valve is recommended if the DHW temperature is set above the factory setting of 119°F.
8. Piping shown is Primary/Secondary. System flow (secondary loop) must be greater than the boiler's primary loop flow.
9. Install a minimum of 12 diameters of straight pipe upstream of all circulators.
10. VERY IMPORTANT - Minimum flow rates outlined in this manual must be maintained through the heat exchanger to minimize short cycling.

### WARNING

The piping will not support the weight of the circulators. Refer to the circulator manufacturer's instructions to properly support the circulator. Failure to comply with these instructions could result in property damage, severe personal injury, or death.



## Primary / Secondary Piping with Pumps & DHW Priority (Outdoor Reset) All Models

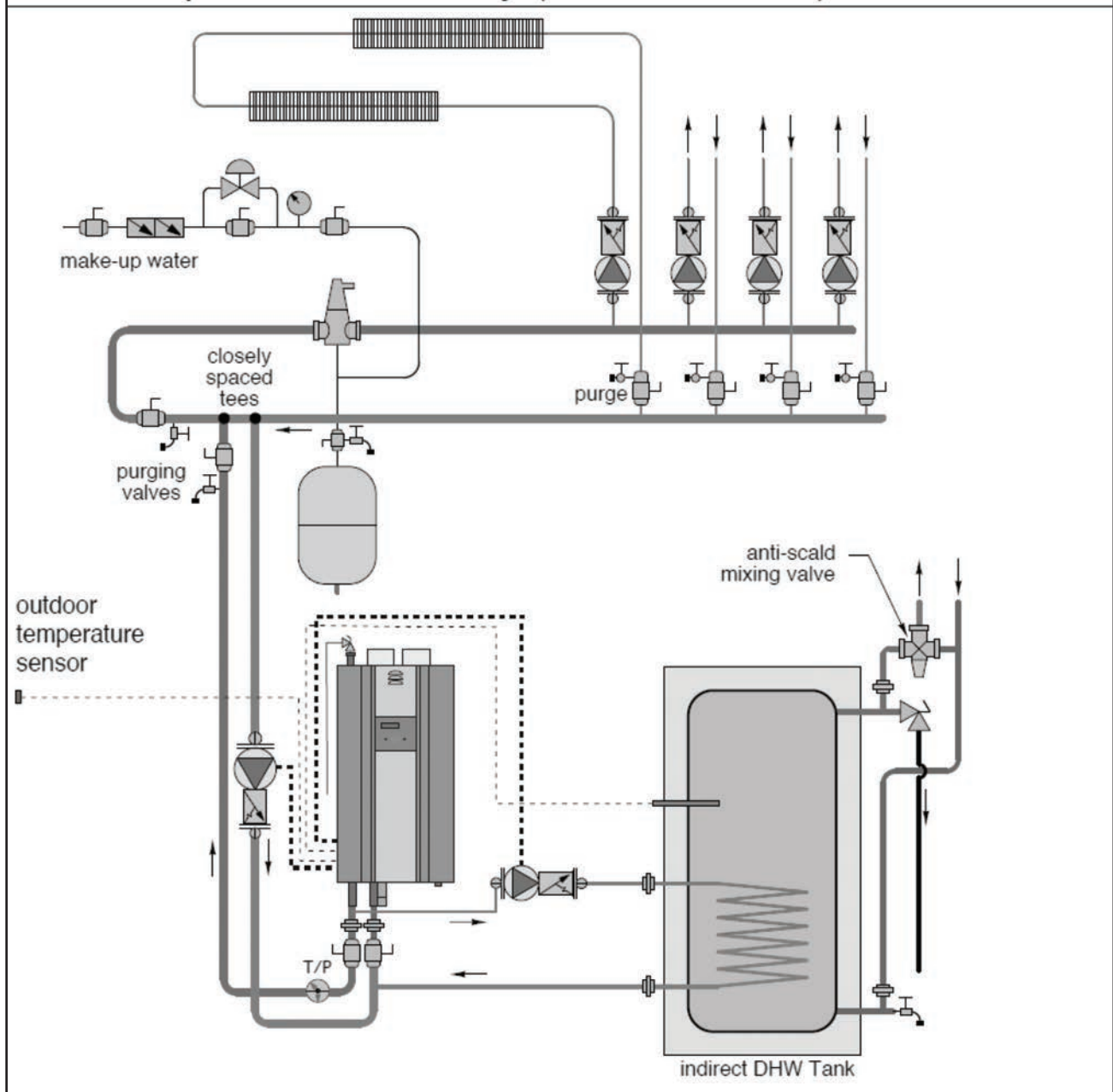

Figure 13 - Primary / Secondary Piping with Pumps and Indirect Priority

### NOTES:

1. This drawing is meant to show system piping concept only. Installer is responsible for all equipment and detailing required by local codes.
2. All closely spaced tees shall be within 4 pipe diameters center to center spacing.
3. A minimum of 6 pipe diameters of straight pipe shall be installed upstream and downstream of all closely spaced tees.
4. The minimum pipe size for connecting an indirect water heater is 1"
5. The minimum pipe size for connecting a 55/80/110 - 1", 155/199/285 - 1.25", 399 - 1.5".
6. Circulators are shown with isolation flanges. The alternative is standard flanges with full port ball valves. Purge valves can be used with circulator flanges as an alternative.
7. A mixing valve is recommended if the DHW temperature is set above the factory setting of 119°F.
8. Piping shown is Primary/Secondary. System flow (secondary loop) must be greater than the boiler's primary loop flow.
9. Install a minimum of 12 diameters of straight pipe upstream of all circulators.
10. VERY IMPORTANT – Minimum flow rates outlined in this manual must be maintained through the heat exchanger to minimize short cycling.

### WARNING

The piping will not support the weight of the circulators. Refer to the circulator manufacturer's instructions to properly support the circulator. Failure to comply with these instructions could result in property damage, severe personal injury, or death.

## Multiple Boilers with Primary / Secondary Piping with Zone Circulators & Indirect Circulator All Models

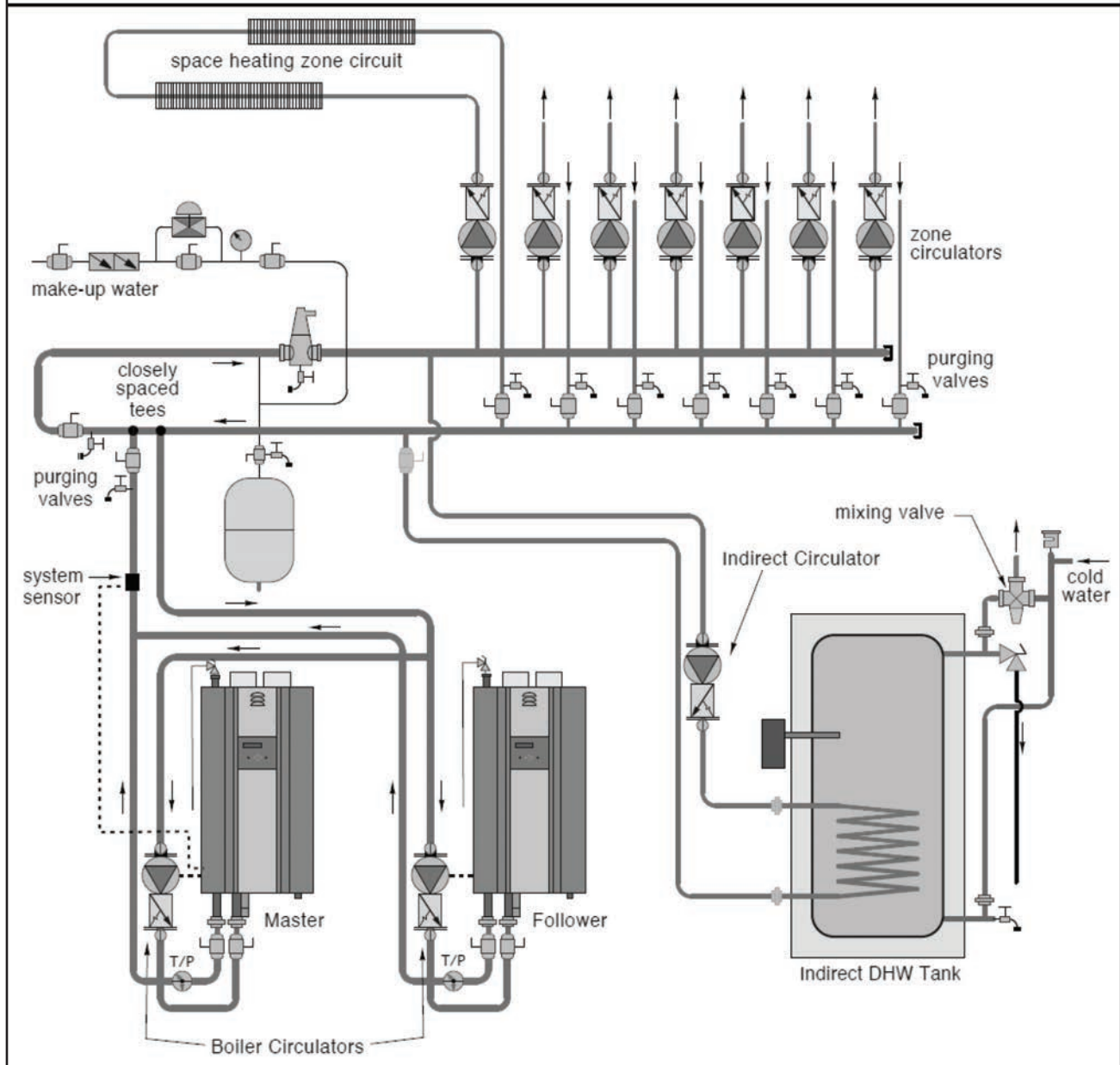

Figure 14 - Multiple Boilers - Primary / Secondary Piping with Pumps and Indirect Priority

### NOTES:

1. This drawing is meant to show system piping concept only. Installer is responsible for all equipment and detailing required by local codes.
2. All closely spaced tees shall be within 4 pipe diameters center to center spacing.
3. A minimum of 6 pipe diameters of straight pipe shall be installed upstream and downstream of all closely spaced tees.
4. The minimum pipe size for connecting an indirect water heater is 1"
5. The minimum pipe size for connecting a 55/80/110 - 1", 155/199/285 - 1.25", 399 - 1.5".
6. Circulators are shown with isolation flanges. The alternative is standard flanges with full port ball valves. Purge valves can be used with circulator flanges as an alternative.
7. A mixing valve is recommended if the DHW temperature is set above the factory setting of 119°F.
8. Piping shown is Primary/Secondary. System flow (secondary loop) must be greater than the boiler's primary loop flow.
9. Install a minimum of 12 diameters of straight pipe upstream of all circulators.
10. VERY IMPORTANT - Minimum flow rates outlined in this manual must be maintained through the heat exchanger to minimize short cycling.

### **WARNING**

The piping will not support the weight of the circulators. Refer to the circulator manufacturer's instructions to properly support the circulator. Failure to comply with these instructions could result in property damage, severe personal injury, or death.

## Part 5 - Venting and Condensate Removal

### DANGER

The boiler must be vented as detailed in this section. Ensure exhaust vent and intake piping complies with these instructions regarding vent system. Inspect finished exhaust vent and intake piping thoroughly to ensure all joints are well secured, airtight, and comply with all applicable code requirements, as well as the instructions provided in this manual. Failure to properly install the vent system will result in severe personal injury or death.

### A. General

### DANGER

This boiler is certified as a "Category IV" appliance and requires a special venting system. The vent system will operate with a positive pressure in the pipe. Exhaust gases must be piped directly outdoors using the vent materials and rules outlined in these instructions. Do not connect vent connectors serving appliances vented by natural draft into any portion of mechanical draft systems operating under positive pressure. Follow the venting instructions carefully. Failure to do so will result in substantial property damage, severe personal injury, or death.

1. Installation should be made in accordance with the regulations of the Authority Having Jurisdiction, local code authorities, and utility companies which pertain to this type of water heating equipment.
2. Install the venting system in accordance with these instructions and with the National Fuel Gas Code, ANSI Z223.1/ NFPA 54, CAN/CGA B149, and / or applicable provisions of local building codes.
3. This boiler must be vented with materials, components, and systems listed and approved for Category IV appliances.

### DANGER

Exhaust and intake are to be piped separately. This boiler cannot share a common exhaust or intake with multiple appliances. Failure to follow these instructions will result in substantial property damage, severe personal injury, or death.

**NOTE:** To avoid contamination often contained in indoor air, it is best to pipe all intake combustion air directly to the outdoors.

**NOTE:** If exhaust vent pipe system passes through an unheated space such as an alcove or attic, the space must be heated or the pipe must be insulated. The insulation must have an R value sufficient to prevent freezing of the condensate.

### WARNING

Improper seating of vent pipe gaskets can cause eventual gasket failure and exhaust gas leakage. Ensure the exhaust vent pipe is properly beveled and seated before insertion into the flue adapter. Failure to do so could result in property damage, severe personal injury, or death.

For closet and alcove installations: CPVC, polypropylene, or stainless steel venting material **MUST BE USED**. Failure to follow this statement could result in product damage, severe personal injury, or death.

### WARNING

#### Breathing Hazard - Carbon Monoxide Gas



- Do not operate heater if flood damaged.
- Install vent system in accordance with local codes and manufacturers installation instructions.
- Do not obstruct heater air intake or exhaust. Support all vent piping per manufacturers installation instructions.
- Do not place chemical vapor emitting products near unit.
- According to NFPA 720, carbon monoxide detectors should be installed outside each sleeping area.
- Never operate the heater unless it is vented to the outdoors.
- Analyze the entire vent system to make sure that condensate will not become trapped in a section of vent pipe and therefore reduce the open cross sectional area of the vent.

LP-304-FR

**Breathing carbon monoxide can cause brain damage or death. Always read and understand instruction manual.**

### DANGER

Due to the extreme flammability of most glues, cements, solvents, and primers used to join plastic exhaust vent and intake pipes, explosive solvent vapors must be cleared from all vent piping before start-up. Avoid using excess cement or primer, as this may pool in the vent pipes. Vent assemblies should be allowed to cure for a period of at least 8 hours before powering a connected appliance. Failure to follow these instructions will result in substantial property damage, severe personal injury, or death. It is the installers' responsibility to understand the hazards associated with explosive solvents and take the necessary precautions to avoid these risks.

### WARNING

DO NOT insulate the first 3 feet of the exhaust vent. CPVC, Polypropylene, or Stainless Steel pipe material **MUST** be used for the first 3 feet of the vent run if the exhaust vent is insulated or passes through an enclosed space greater than 6", such as a wall. The balance of the vent run can be installed with standard Schedule 40 PVC pipe. Failure to comply with this warning could result in property damage, severe personal injury, or death.

Exhaust vent adaptors are not designed as load-bearing devices, and must not be used to support exhaust vent piping. All vent pipes must be properly connected, supported, and the exhaust vent must be pitched a minimum of 1/4" per foot back to the boiler to allow drainage of condensate. Failure to properly support vent piping and follow the information in this statement could result in product damage, severe personal injury, or death.

## B. Approved Materials for Exhaust Vent and Intake Pipe

Item	Material	Standards for Installation In:	
		United States	Canada
Exhaust Vent or Intake Pipe and Fittings	PVC Schedule 40/80	ANSI / ASTM D1785	PVC, CPVC, and PP Venting Must be ULC-S636 Certified. IPEX is an approved manufacturer in Canada.
	PVC-DWV*	ANSI / ASTM D2665	
	CPVC Schedule 40/80	ANSI / ASTM F441	
	Polypropylene	UL-1738	
	Stainless Steel AL29-4C	Certified for Category IV and Direct Vent Appliance Venting	
Pipe Cement / Primer	PVC	ANSI / ASTM D2564	IPEX System 636 Cements and Primers
	CPVC	ANSI / ASTM F493	

### DANGER

- The exhaust and intake components installed with this boiler must be used for near boiler piping BEFORE transitioning to the approved materials listed above. DO NOT REMOVE these installed components. Doing so WILL VOID boiler warranty.
- PVC / CPVC pipe and fittings of the same diameter are considered interchangeable.
- DO NOT use Foam Core Pipe in any portion of the exhaust piping from this boiler.
- DO NOT connect PVC / CPVC to PP without an approved vent connector.
- When installing AL29-4C vent piping, install a PVC-to-stainless adapter at the boiler vent connection, and at the termination when using a PVC termination kit. DO NOT mix AL29-4C piping from different manufacturers unless using adapters specifically designed for the purpose by the manufacturer.
- A double wall vent may be used when using stainless steel vent material in a freezing climate.
- \*PVC-DWV may be used for air intake applications ONLY.
- Contact the venting material manufacturer if there is any question about the applicability of the proposed venting material.

Failure to follow these directions will result in substantial property damage, severe personal injury, or death.

Table 8 - Approved Materials for Exhaust Vent and Intake Pipe

### WARNING

DO NOT mix components from different venting systems without proper adapters. The vent system could fail, causing leakage of flue products into the living space. Use only the approved pipe and fitting materials, and primer and cement specifically designed for the material used, as listed in the above table. Failure to do so could result in property damage, serious injury, or death.

### CAUTION

High heat sources (generating heat 100°F / 37°C or greater, such as boiler flue pipes, space heaters, etc.) may damage plastic components of the boiler as well as plastic vent pipe materials. Such damages ARE NOT covered by warranty. It is recommended to keep a minimum clearance of 8" from high heat sources. Observe heat source manufacturer instructions, as well as local, state, provincial, and national codes, laws, regulations, and ordinances when installing this boiler and related components near high heat sources.

**NOTE:** The use of double-wall vent or insulated material for the combustion air intake pipe is recommended in cold climates to prevent the condensation of airborne moisture in the incoming combustion air.

### DANGER

You must not use "B" vent in an exhaust application. "B" vent is for intake applications ONLY. Using "B" vent in an exhaust application will result in serious injury or death.

## C. Additional Requirements for Installation in Canada

1. Installations must be made with a vent pipe system certified to ULC-S636. IPEX is an approved vent manufacturer in Canada supplying vent material listed to ULC-S636. Additionally, you may use AL29-4C stainless steel venting to comply with Canadian requirements.
2. The first three (3) feet of vent pipe from the boiler flue outlet must be readily accessible for visual inspection.
3. The components of the certified vent system must not be interchanged with other vent systems or unlisted pipe / fittings.  
Cellular foam core piping may be used on air inlet piping **only**.

## D. Exhaust Vent and Intake Pipe Location

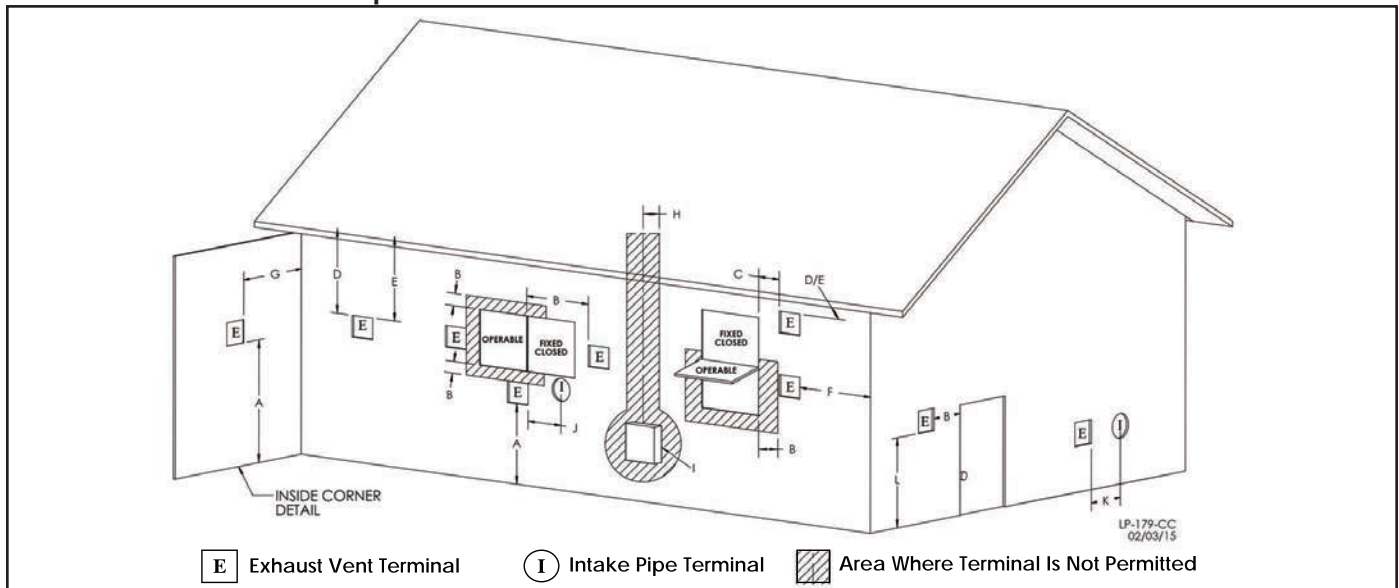

Figure 15 - Exit Terminals for Direct Vent Systems - ANSI Z223.1 / NFPA 54 for US and CAN/CSA B149.1 for Canada

### DETERMINE EXHAUST VENT AND INTAKE PIPE LOCATION – NOTES:

#### INSTALLATIONS IN THE UNITED STATES

A. Provide a minimum of 1 foot clearance from the bottom of the exhaust vent and intake pipe above the expected snow accumulation level. Snow removal may be necessary to maintain clearance.

B. Provide a minimum of 1 foot distance from exhaust vent termination to any door, operable window, or gravity intake into any building.

C. Provide a minimum of 1 foot distance from exhaust vent termination to any permanently closed door or window.

D. Provide a minimum of 4 feet vertical clearance from the exhaust vent to all roof overhangs.

E. Locating exhaust vent termination near roof overhangs will result in the formation of icicles in freezing weather, and could result in blockage of the exhaust vent. To prevent icicles from forming, maintain 4 feet vertical clearance from the exhaust vent to all roof overhangs.

F. Provide 4 feet clearance from the outside corner of vertical walls, chimneys, etc., as well as horizontal corners created by roof overhangs.

G. Provide 6 feet clearance from the inside corner of vertical walls, chimneys, etc., as well as horizontal corners created by roof overhangs.

H. Provide 4 feet clearance from center line within a height of 15 feet above electrical meters, gas meters, gas regulators, relief equipment, exhaust fans and inlets.

I. Provide 4 feet horizontal clearance from electrical meters, gas meters, gas regulators, relief equipment, exhaust fans and inlets. In no case shall the exit terminal be above or below the aforementioned equipment unless the 4 foot horizontal distance is maintained.

J. This boiler vent system shall terminate at least 3 feet (0.9 m) above any forced air intake located within 10 ft (3 m).

**NOTE:** This does not apply to the combustion air intake of a direct-vent appliance.

K. When venting with a two pipe system, maximum distance between exhaust vent and intake pipe is 6 feet (1.8 m). Minimum distance between exhaust vent and intake pipe on single direct vented appliance is 10" (0.255 m) center-to-center. Minimum distance between exhaust vents and intake pipes on multiple boilers is 10" (0.255 m) center-to-center.

L. When adjacent to a public walkway, locate exit terminal at least 7 feet above grade.

In addition:

- Total length of vent piping shall not exceed the limits specified in this manual.
- The vent piping for this direct vented appliance is approved for zero clearance to combustible construction.
- The flue products coming from the exhaust vent will create a large plume when the boiler is in operation. Avoid venting in areas that will affect neighboring buildings or be considered objectionable.
- DO NOT locate exhaust vent or intake pipe in a parking area where machinery may damage the pipe.
- DO NOT locate the exhaust vent or intake pipe terminals under a porch, balcony, or veranda.
- Avoid terminating exhaust vents near shrubs, air conditioners, or other objects that will obstruct the exhaust stream.
- DO NOT vent over a public walkway. Condensate could drip or freeze and create a nuisance or hazard.
- **NOTE:** Due to potential moisture build-up, sidewall venting may not be the preferred venting option. Carefully consider venting installation and location to save time and cost.

#### INSTALLATIONS IN CANADA

**NOTE:** Canadian installation must comply with the CAN/CSA B149.1 code and applicable local codes and supersede the restrictions for the United States outlined in this section.

### WARNING

It is required to insert exhaust and intake screens into the vent terminations to prevent blockage caused by debris or birds. Failure to keep terminations clear could result in property damage, severe personal injury, or death.

The building owner is responsible for keeping the exhaust and intake terminations free of snow, ice, or other potential blockages, as well as scheduling routing maintenance. Failure to keep the vent piping terminations clear and properly maintain the boiler could result in property damage, severe personal injury, or death.

For each floor containing bedroom(s), a carbon monoxide detector and alarm shall be placed in the living area outside the bedrooms, as well as in the room that houses the boiler. Detectors and alarms shall comply with NFPA 720 (latest edition). Failure to comply with these requirements could result in property damage, severe personal injury, or death.

**E. Exhaust Vent and Intake Pipe Sizing**

1. The exhaust vent and intake pipe size is 3" for 55 - 285 models and 4" for the 399 model.
2. The maximum total equivalent length of exhaust vent and intake pipe **should not exceed 200 feet for all models EXCEPT the 285 model. Total equivalent length for the 285 model should not exceed 150 feet.**

a. The equivalent length of elbows, tees, and other fittings are listed in the Friction Loss Table.

Friction Loss Equivalent in Piping and Fittings			
Fittings or Piping	Equivalent Feet		
	3"	4"	6"
90 Degree Elbow*	5'	3'	3'
45 Degree Elbow	3'	3'	2'
Coupling	0'	0'	0'
Air Inlet Tee	0'	0'	0'
Straight Pipe	1'	1'	1'
Concentric Kit	3'	N/A	N/A
V Series Vent Kit	1'	1'	1'
AL20 4c Vent Terminal	1'	1'	1'

Table 9 - \*Friction loss for long radius elbow is 1 foot less. NOTE: Consult Polypropylene venting instructions for friction loss and pressure drop equivalents.

b. For example: If the exhaust vent is 3" in diameter, has two 90° elbows, and 10 feet of PVC pipe we will calculate:  
 Exhaust Vent Equivalent Length = (2x5) + 10 = 20 feet.

Further, if the 3" intake pipe has two 90° elbows, one 45° elbow, and 10 feet of PVC pipe, the following calculation applies:

Intake Pipe Equivalent Length = (2x5) + 3 + 10 = 23 feet.

The total equivalent length is 43 feet, well below the maximum.

c. Effort should be made to keep a minimum difference in equivalent length between the exhaust vent and intake pipe.

3. The minimum total equivalent length is 16 feet.

<b>CAUTION</b>
Do not exceed the maximum lengths for vent pipes. Excessive length could result in boiler shutdown and property damage.
Failure to provide a minimum total vent length of 16 equivalent feet could result in property damage and improper product operation.

**F. Longer Vent Runs**

The maximum total equivalent length can be extended by increasing the diameter of both the exhaust vent and intake pipes equally. However, the transitions should begin a minimum of 16 equivalent feet from the boiler. Transitions should always be made in vertical sections of pipe to prevent the condensate from pooling in the vent pipe.

On all models EXCEPT the 285 model, the maximum equivalent length for increased diameter vent pipes is 275 ft, which includes 16 ft from with boiler with a transition total of 259 ft upsize piping for longer vent runs. On the 285 model, the maximum equivalent length for increased diameter vent pipes is 250 ft., which includes the 16 ft from the boiler with a transition total of 234 ft upsize piping for longer vent runs.

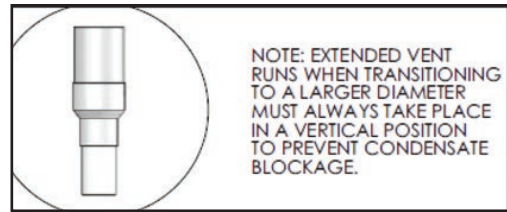

Figure 16 - Extended Vent Runs

Standard Vent Connection	Reducing Coupling	Increased Vent Size
3"	4" x 3"	4"
4"	6" x 4"	6"
6"	8" x 6"	8"

Table 10 - Vent Run Transition

<b>⚠ DANGER</b>
Total maximum equivalent length of increased diameter exhaust vent and intake pipe must not exceed the lengths defined in this manual. Failure to keep the total equivalent length below the maximum lengths determined in this manual will result in faulty boiler operation, substantial property damage, serious personal injury, or death.

**G. Exhaust Vent and Intake Pipe Installation**

<b>⚠ WARNING</b>
All joints of positive pressure vent systems must be sealed completely to prevent leakage of flue products into the living space. Failure to do so could result in property damage, serious injury, or death.

1. Use only solid PVC, CPVC, or stainless steel pipe or a Polypropylene vent system approved for use with Category IV appliances.

FOAM CORE PIPING IS NOT APPROVED FOR EXHAUST VENT APPLICATIONS. Foam core piping may be used on air inlet piping **only**.

2. Remove all burrs and debris from joints and fittings.
3. When using PVC or CPVC pipe, all joints must be properly cleaned, primed, and cemented. Use only cement and primer approved for use with the pipe material. Cement must conform to ASTM D2564 for PVC and ASTM F493 for CPVC pipe. **NOTE: DO NOT CEMENT POLYPROPYLENE PIPE.**
4. Ensure the vent is located where it will not be exposed to prevailing winds.
5. In all roof venting applications, exhaust discharge must point away from the pitch of the roof.
6. If the exhaust vent is to be terminated in a walled off area (such as a roof with a parapet wall), ensure the exhaust vent terminates a minimum of 10' from nearest wall and extends level with or above the top of the wall. This will ensure flue gas does not get trapped and possibly recirculated into the intake air pipe, which could contaminate the combustion air.
7. To prevent water leakage, install adequate roof flashing where the pipe enters the roof.
8. Do not locate vent over public walkways, driveways, or parking lots. Condensate could drip and freeze, resulting in a slip hazard or damage to vehicles and machinery.
9. Due to potential moisture build-up, sidewall venting may not be the preferred venting option. To save time and cost, carefully consider venting installation and location.

- 10. Horizontal lengths of exhaust vent must slope back towards the boiler not less than 1/4" per foot to allow condensate to drain from the vent pipe.
- 11. The exhaust vent must terminate where vapors cannot make accidental contact with people or pets, or damage shrubs or plants.
- 12. In vacant chimney applications, install and seal a rain cap over existing chimney openings.
- 13. All piping must be fully supported. Use pipe hangers at a minimum of 4 foot intervals to prevent sagging of the pipe where condensate may form.
- 14. Do not use the boiler to support any piping.
- 15. Ensure the outdoor exhaust vent termination is screened to prevent blockage caused by debris or birds.
- 16. Ensure the outdoor intake pipe termination is screened to prevent blockage caused by debris or birds.

The following table lists optional exhaust/intake terminations available from HTP:

Description	Stock Code
3" PVC Concentric Termination Kit	KGAVT0601CVT
3" Stainless Steel Termination Kit	V1000
4" Stainless Steel Termination Kit	V2000
6" Stainless Steel Termination Kit	V3000
3" Polypro Vent Kit	8400P-001

Table 11 - Optional Vent Kits

**H. Applications**

**1. Direct Vent Installation of Exhaust and Intake**

If installing a direct vent option, combustion air must be drawn from the outdoors directly into the boiler intake, and exhaust must terminate outside. There are three basic direct vent options detailed in this manual: 1. Side Wall Venting, 2. Roof Venting, and 3. Unbalanced Venting.

Be sure to locate the boiler such that the exhaust vent and intake pipe can be routed through the building and properly terminated. Different vent terminals can be used to simplify and eliminate multiple penetrations in the building structure (see Optional Equipment in Venting Section). The exhaust vent and intake pipe lengths, routing and termination methods must all comply with the methods and limits given in the Venting section of this manual.

When installing a combustion air intake from outdoors, care must be taken to utilize uncontaminated combustion air. **NOTE:** To prevent combustion air contamination, see Table 2.

**⚠ WARNING**

Take extra precaution to adequately support the weight of vent pipes terminating through the roof. Failure to properly support roof terminated piping could result in property damage, serious injury, or death.

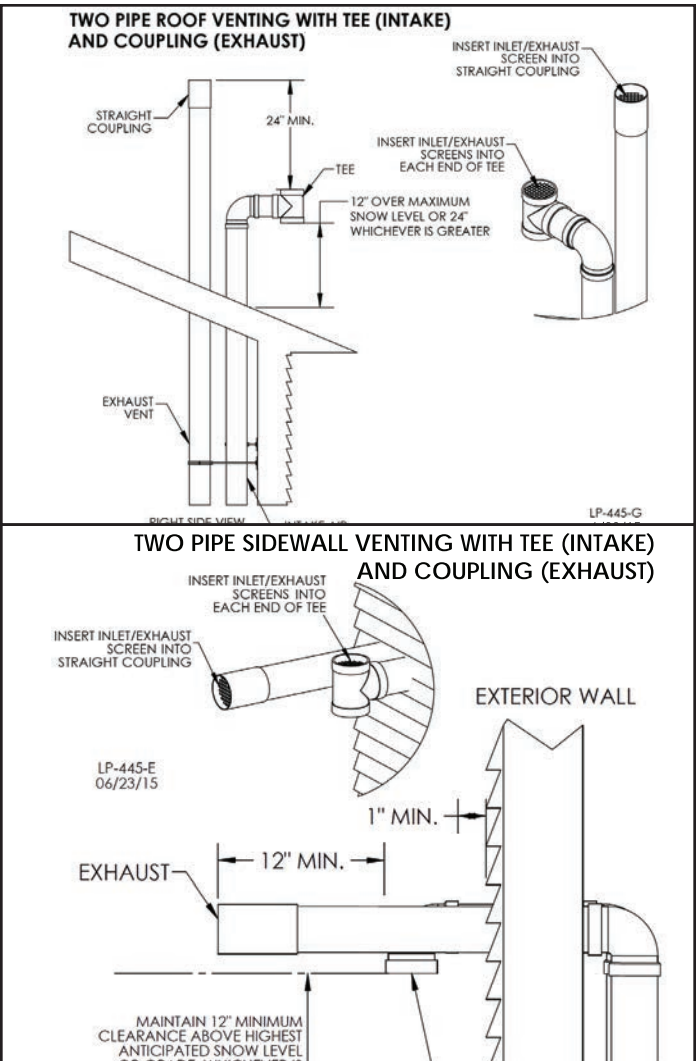

Figure 17 - Two Pipe Roof and Sidewall Venting

**NOTE:** These drawings are meant to demonstrate system venting only. The installer is responsible for all equipment and detailing required by local codes.

**⚠ WARNING**

All vent pipes must be glued, properly supported, and the exhaust pitched a minimum of 1/4" per foot back to the boiler to allow drainage of condensate. When placing support brackets on vent piping, the first bracket must be within 1 foot of the boiler and the balance of 4 foot intervals on the vent pipe. Venting must be readily accessible for visual inspection from the first three feet from the boiler.

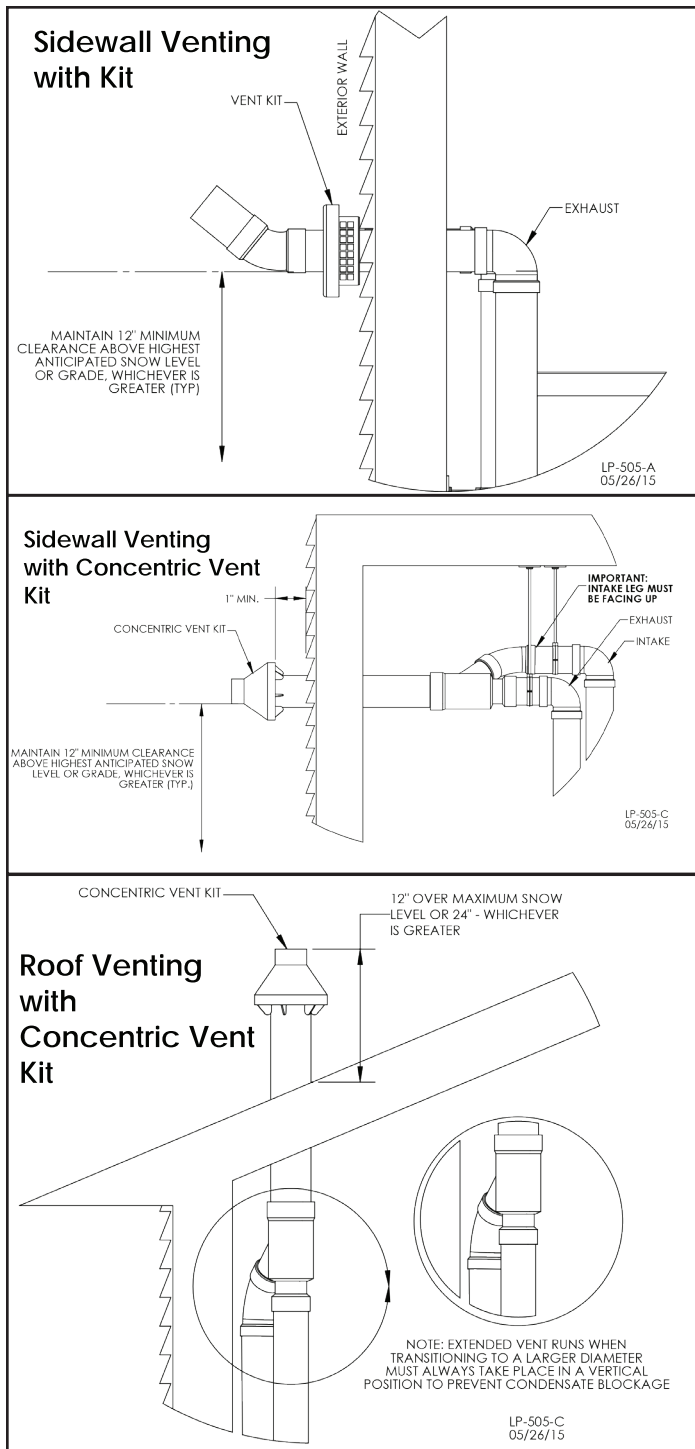

Figure 18 - Venting with Optional Kits (NOT INCLUDED WITH THE BOILER)

NOTE: These drawings are meant to demonstrate system venting only. The installer is responsible for all equipment and detailing required by local codes.

**WARNING**

All vent pipes must be glued, properly supported, and the exhaust pitched a minimum of 1/4" per foot back to the boiler to allow drainage of condensate. When placing support brackets on vent piping, the first bracket must be within 1 foot of the boiler and the balance of 4 foot intervals on the vent pipe. Venting must be readily accessible for visual inspection from the first three feet from the boiler.

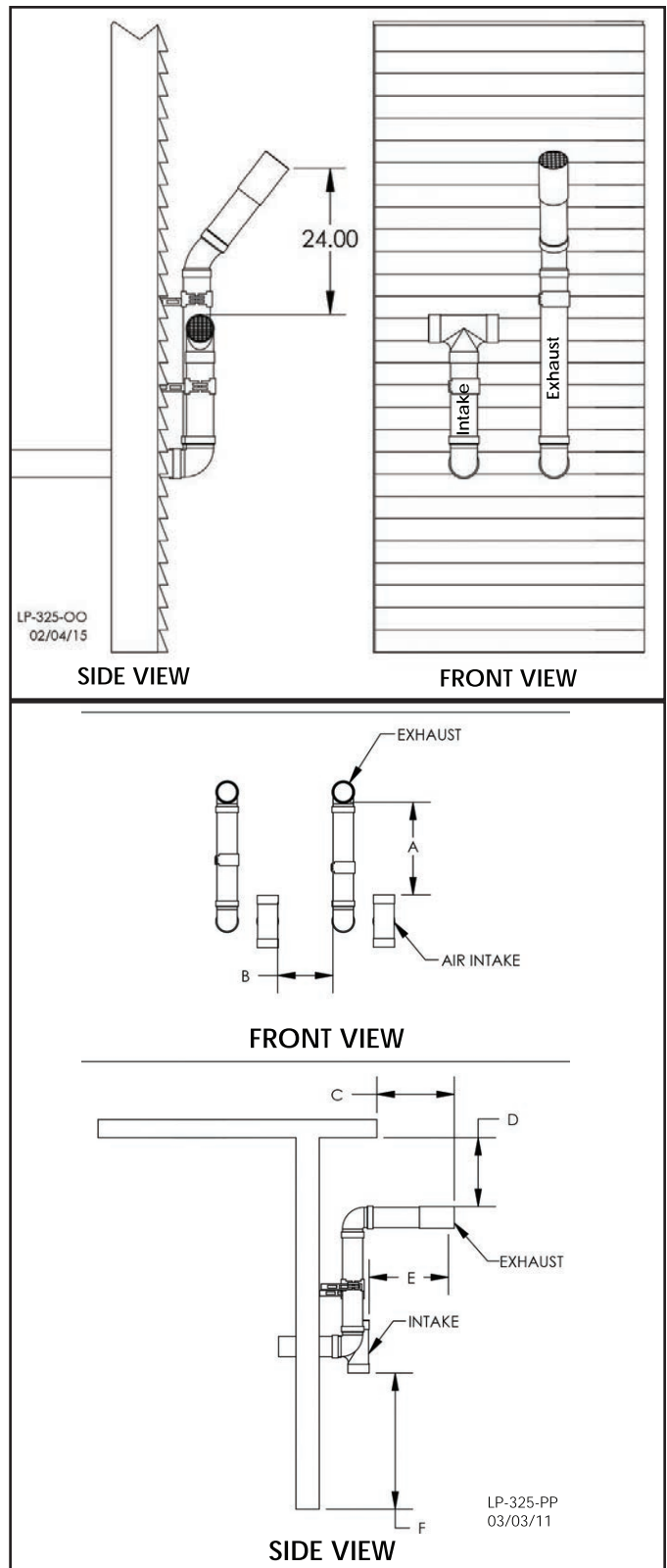

Figure 19 - Horizontal (Snorkel) Venting

NOTES:

- A. For every 1" of overhang, the exhaust vent must be located 1" vertical below overhang (overhang means top of building structure and not two adjacent walls [corner of building]).
- B. Typical installations require 12" minimum separation between bottom of exhaust outlet and top of air intake.
- C. Maintain 12" minimum clearance above highest anticipated snow level or grade (whichever is greater).
- D. Minimum 12" between vents when installing multiple vents.
- E. 12" minimum beyond air intake.



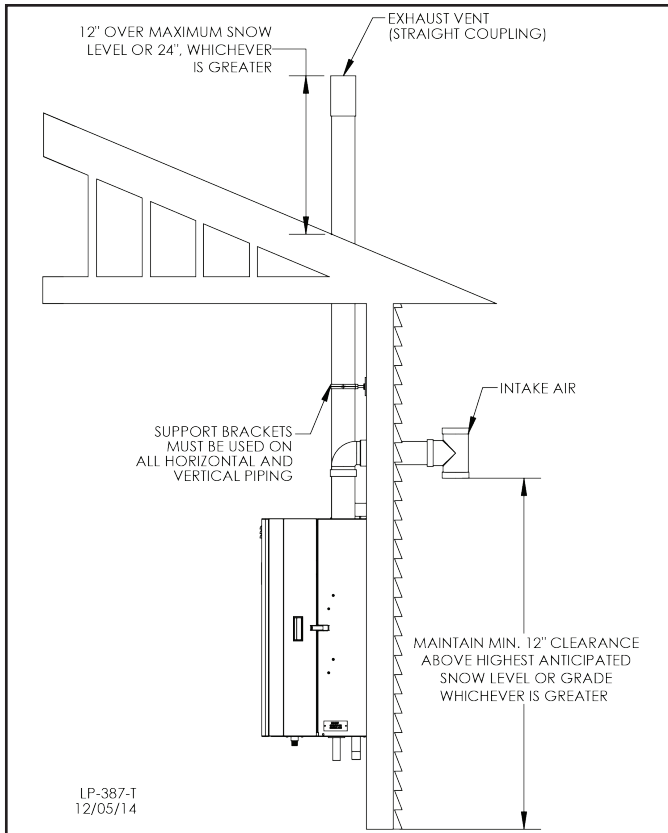

Figure 20 - Unbalanced Venting - Roof Exhaust and Sidewall Intake

**NOTE:** These drawings are meant to demonstrate system venting only. The installer is responsible for all equipment and detailing required by local codes.

**WARNING**

All vent pipes must be glued, properly supported, and the exhaust pitched a minimum of 1/4" per foot back to the boiler to allow drainage of condensate. When placing support brackets on vent piping, the first bracket must be within 1 foot of the boiler and the balance of 4 foot intervals on the vent pipe. Venting must be readily accessible for visual inspection from the first three feet from the boiler.

An unbalanced vent system can be installed **ONLY** when the exhaust is in the vertical position. Failure to do so could result in serious personal injury or death.

**2. Venting Through an Existing System**

This boiler may be vented through an existing unused vent system. The inner diameter of the existing vent system is utilized for the combustion air source. Two methods have been approved for such venting: Concentric Venting Through an Existing System and Venting as a Chase.

Vent / Air Intake Size	Minimum Existing Vent / Chase Size
3"	5"
4"	7"

Table 12 - Minimum Existing Vent / Chase Sizing

**DANGER**

Do not install the boiler into a common existing vent with any other appliance. This will cause flue gas spillage or boiler malfunction, resulting in substantial property damage, serious personal injury, or death.

**CAUTION**

Contractors must check state and local codes before installing through an existing vent opening. State and local codes always take precedence over manufacturer's instructions. Failure to check state and local codes before installing through an existing opening could result in property damage and add significantly to installation costs.

If an existing venting system is converted for use with this boiler, the installer must ensure that the existing venting system is clean and free from particulate contamination that could damage the boiler. Failure to do so could result in property damage and boiler failure. Such failure IS NOT covered under warranty.

**Concentric Venting Through an Existing System**

**NOTE:** The following instructions refer only to venting through an existing vent system, and not to venting with HTP's optional concentric vent kits. Refer to Concentric Vent Kit installation manual (LP-166) for further information on venting with the optional concentric vent kits.

Concentric venting through an existing system must run vertically through the roof. See Table 12 for proper minimum vent sizing. Use only the approved venting materials specified in Table 8 for piping the system. All instructions listed in this Venting section apply. See Figures 21-1 and 21-2 for venting demonstrations.

**DANGER**

The upper and lower vent terminations as well as all joints in the venting system must be properly sealed to ensure that all combustion air is drawn properly and exhaust does not leak from the system. Failure to properly seal the venting system will result in property damage, serious personal injury, or death.

**Chase Venting Through an Existing System**

When venting as a chase, follow all instructions included in this Venting section, including those in the previous Concentric Venting Through an Existing System section. See Figure 21-3 for chase venting demonstration.

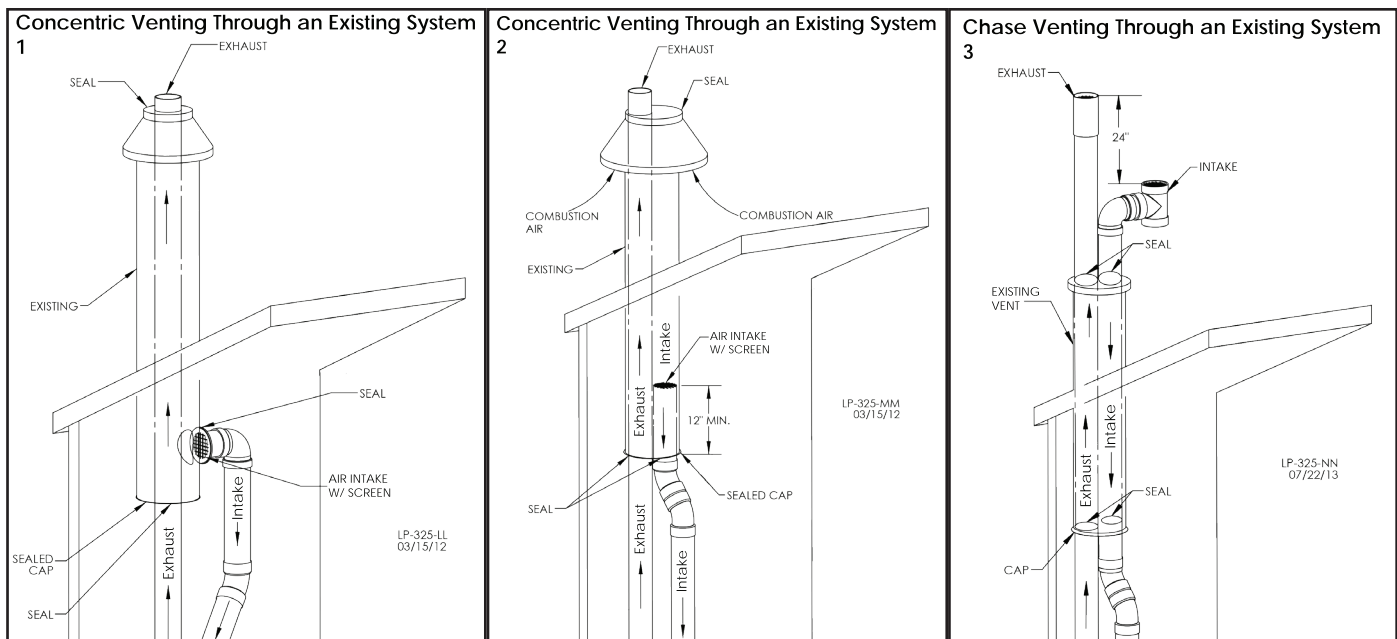

Figure 21 - 1, 2 - Concentric Venting Through an Existing System, 3, Chase Venting Through an Existing System

**NOTE:** These drawings are meant to demonstrate system venting only. The installer is responsible for all equipment and detailing required by local codes.

### 3. Indoor Combustion Air in Confined or Unconfined Space

This boiler requires fresh, uncontaminated air for safe operation and must be installed in a mechanical room where there is adequate combustion and ventilating air. **NOTE: To prevent combustion air contamination, see Table 2.**

Combustion air from the indoor space can be used if the space has adequate area or when air is provided through a duct or louver to supply sufficient combustion air based on the boiler input. **Never obstruct the supply of combustion air to the boiler.** If the boiler is installed in areas where indoor air is contaminated (see Figure 22) it is imperative that the boiler be installed as direct vent so that all combustion air is taken directly from the outdoors into the boiler intake connection.

**Unconfined space** is space with volume greater than 50 cubic feet per 1,000 Btu/hour (4.8 cubic meters per kW) of the total input rating of all fuel-burning appliances installed in that space. Rooms connected directly to this space, through openings not furnished with doors, are considered part of the space.

**Confined space** is space with volume less than 50 cubic feet per 1,000 Btu/hour (4.8 cubic meters per kW) of the total input rating of all fuel-burning appliances installed in that space. Rooms connected directly to this space, through openings not furnished with doors, are considered part of the space.

When drawing combustion air from inside a conventionally constructed building to a confined space, such space should be provided with two permanent openings: one located 6" (15 cm) below the space ceiling, the other 6" (15cm) above the space floor. Each opening should have a free area of one square inch per 1,000 Btu/hr (22cm<sup>2</sup>/kW) of the total input of all appliances in the space, but not less than 100 square inches (645cm<sup>2</sup>).

If the confined space is within a building of tight construction, air for combustion must be obtained from the outdoors as outlined in the Venting section of this manual. See Figure 23.

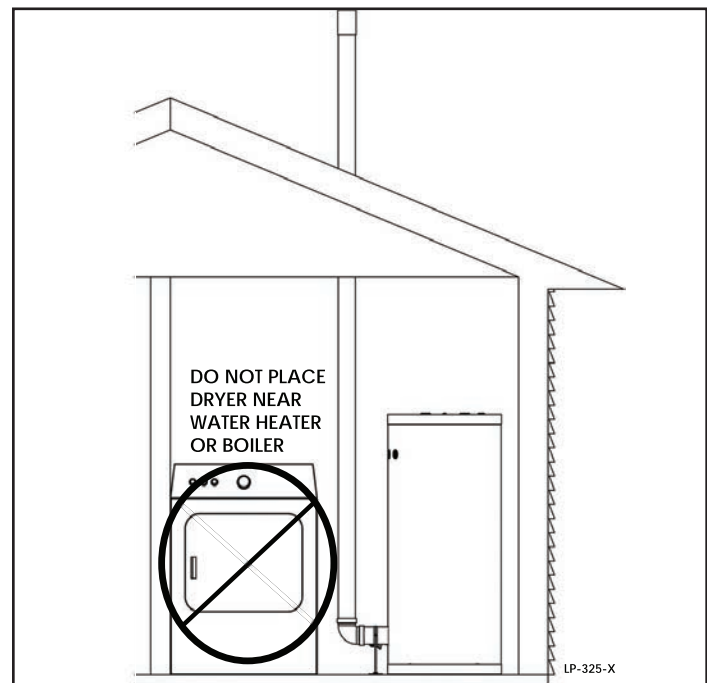



Figure 22 - Do Not Place Appliance Near Dryer

**⚠ WARNING**

**Breathing Hazard - Carbon Monoxide Gas**



- Do not operate heater if flood damaged.
- Install vent system in accordance with local codes and manufacturers installation instructions.
- Do not obstruct heater air intake or exhaust. Support all vent piping per manufacturers installation instructions.
- Do not place chemical vapor emitting products near unit.
- According to NFPA 720, carbon monoxide detectors should be installed outside each sleeping area.
- Never operate the heater unless it is vented to the outdoors.
- Analyze the entire vent system to make sure that condensate will not become trapped in a section of vent pipe and therefore reduce the open cross sectional area of the vent.

LP-304-FR

**Breathing carbon monoxide can cause brain damage or death. Always read and understand instruction manual.**

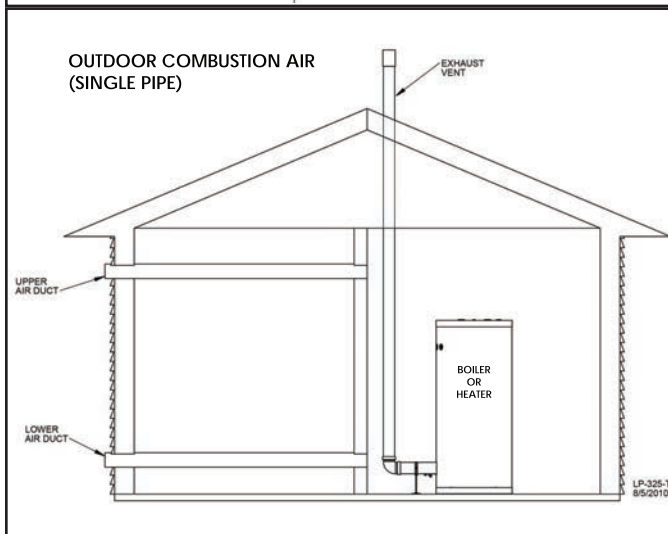
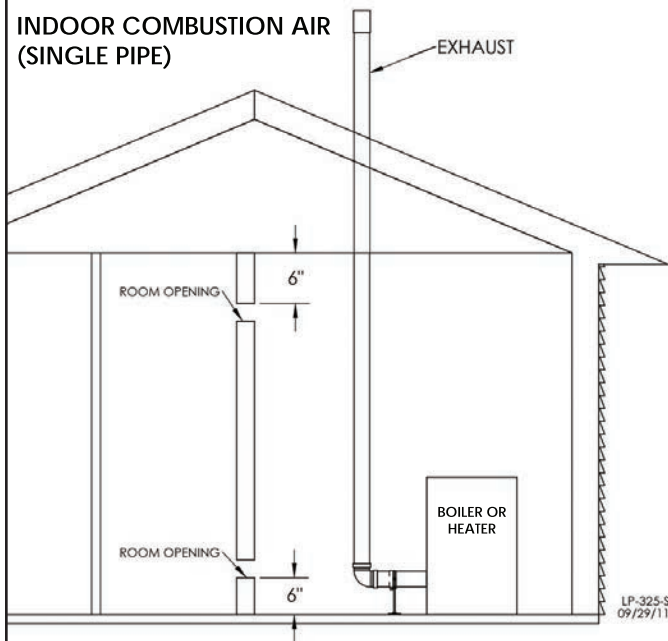

Figure 23 - Indoor and Outdoor Combustion Air - Single Pipe

**I. Condensate Removal System**

**NOTE:** Check with your local gas company to determine if combustion condensate disposal is permitted in your area. In the state of Massachusetts, condensate must be neutralized before entering a drain.

This boiler is a high efficiency appliance, and therefore produces condensate: a by-product of the combustion process. A condensate collection system with an internal float switch monitors condensate level to prevent it from backing up into the combustion system. There is a flexible line that must be piped to a drain or condensate pump.

Condensate from the boiler is slightly acidic with a pH of 3.2 - 4.5. To avoid long term damage to the drainage system and to meet local code requirements, HTP recommends neutralizing condensate with a Condensate Neutralizer Kit (Part # 7450P-212 for EL-80/110/150/220/299/301, Part # 7350P-611 for EL-399). The neutralizer kit connects to the drain system and contains limestone chips that neutralize the pH level of the condensate. The neutralizer kit should be checked annually and the limestone chips replenished if necessary. When replacing the limestone chips, take care to ensure chips are no smaller than 1/2" to avoid blockage in condensate piping (refer to Figure 26 for piping of the condensate neutralizer.)

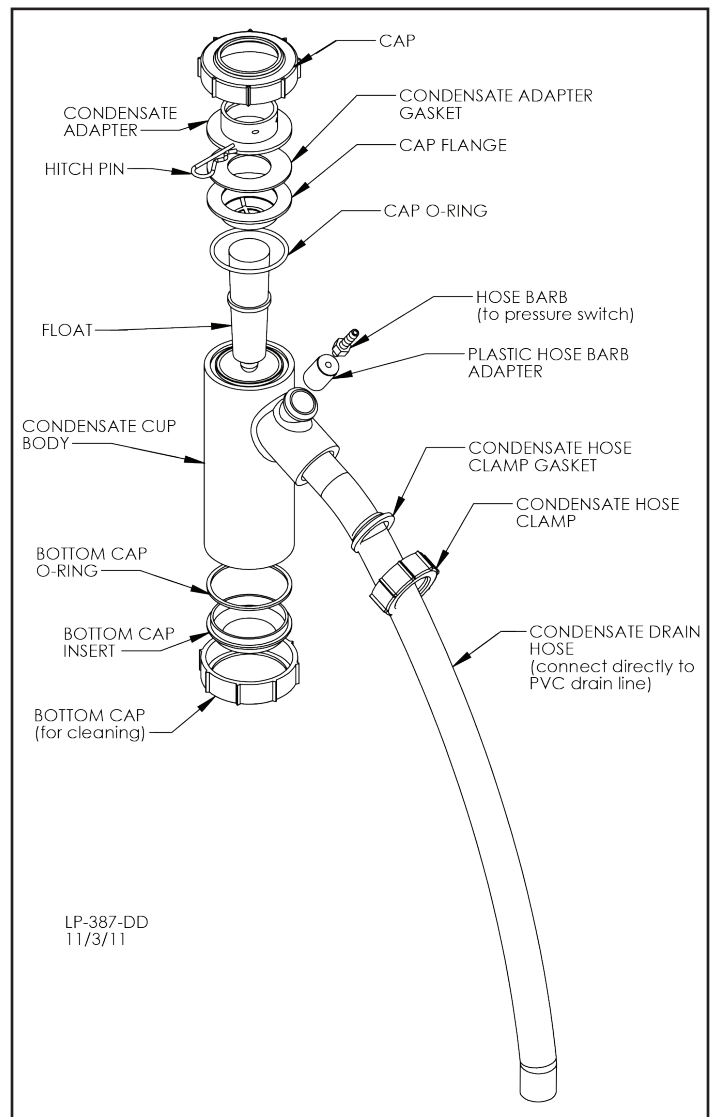

Figure 24 - Condensate Detail

## Condensate Trap Installation Instructions

### **⚠ DANGER**

The condensate trap assembly **MUST BE PROPERLY INSTALLED** according to these instructions when operating the boiler. Operating the boiler without the condensate trap assembly will cause flue gases to leak and result in serious personal injury or death.

1. Ensure all parts shown in Figure 24, Condensate Detail, are included with the condensate trap. If any parts are missing, **DO NOT** install the trap. Replace the entire condensate assembly.

**NOTE:** Before installation, clean out the condensate collector with water to remove any foreign matter that may block the condensate line.

### **⚠ WARNING**

Do not install the condensate assembly if a component is lost or missing. Replace the entire assembly. Failure to follow this warning could result in property damage, serious personal injury, or death.

2. **NOTE:** The installer should fill the condensate trap with tap water prior to assembly on the boiler.

3. Slide the condensate trap adapter onto the drain tube until the holes line up with the groove.

4. Insert stainless steel lock pin to lock condensate adapter to the drain tube.

5. Connect the clear hose from the pressure switch to the hose barb.

### **⚠ WARNING**

Do not operate the boiler without the clear hose attached from the hose barb to the pressure switch. Failure to follow this warning could result in property damage, serious personal injury, or death.

**NOTE:** The use of ¾" PVC or CPVC pipe are acceptable materials for condensate piping. However, use materials approved by the authority having jurisdiction.

In the absence of other authority, PVC and CPVC pipe must comply with ASTM D1785 or D2845. Cement and primer must comply with ASME D2564 or F493. For Canada, use CSA or ULC certified PVC or CPVC pipe, fittings, and cement. If pipe is used, deburr and chamfer pipe to allow proper mating to the drainage assembly.

5. Run condensate drain hose to 1" PVC or CPVC drain pipe. See Figure 26.

**NOTE:** DO NOT cement drain hose to the PVC drainage pipe!

**NOTE:** To allow for proper drainage on long horizontal runs, a second line vent may be required and tubing size may need to increase to 1". Failure to add a second vacuum break could result in condensate backup, improper boiler operation, and nuisance shutdowns.

**NOTE:** See Part 14, this manual, for instructions on how to maintain the condensate trap.

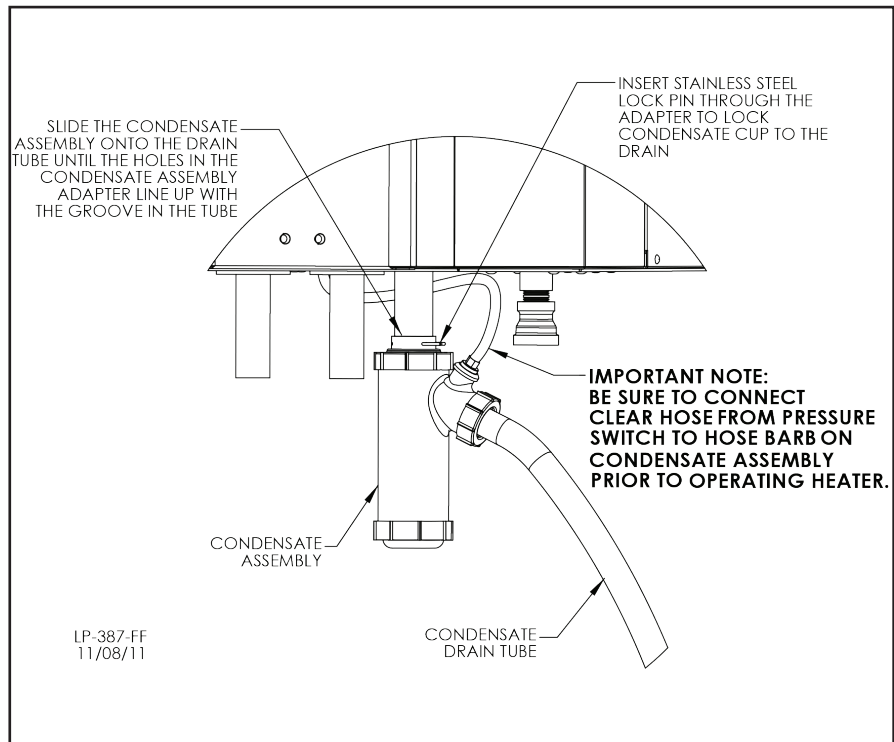

Figure 25 - Condensate Trap Installation

## Condensate Neutralization

Condensate from the boiler is slightly acidic with a pH of 3.2 - 4.5. To avoid long term damage to the drainage system and to meet local code requirements, HTP recommends neutralizing the condensate with a Condensate Neutralizer Kit (Part # 7450P-212). The neutralizer kit connects to the drain system and contains limestone chips that neutralize the pH level of the water vapor. The neutralizer kit should be checked annually and the limestone chips replenished if necessary. When replacing the limestone chips, take care to ensure chips are no smaller than ½" to avoid blockage in condensate piping (for piping details, refer to condensate neutralizer installation instruction.)

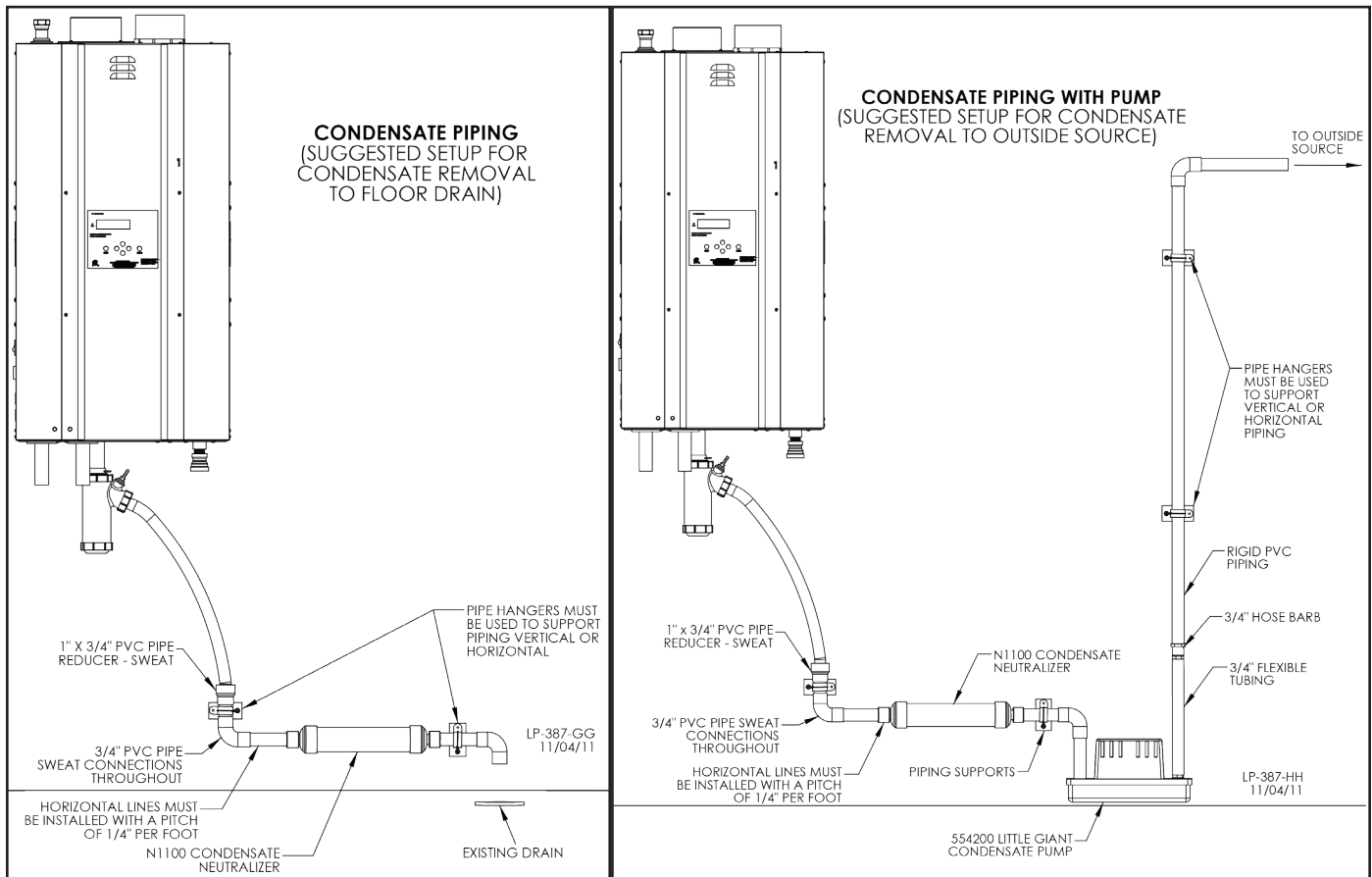

Figure 26 - Condensate Piping Suggestions

**NOTES:**

1. Condensate line must be pitched at least  $\frac{1}{4}$ " per foot to properly drain. If this cannot be done, or a very long length of condensate hose is used, increase the condensate line to a minimum of 1" ID and place a tee in the line after the condensate neutralizer to properly reduce vacuum lock in the drain line.
2. PVC or CPVC pipe should be the only material used for condensate line. Steel, brass, copper, and other metals will be subject to corrosion or deterioration.
3. A frozen condensate line could result in a blocked vent condition. It is very important to protect the condensate line from freezing temperatures or any type of blockage. In installations that may encounter sustained freezing conditions, the use of heat tape is recommended to avoid freezing of the condensate line. It is also recommended to bush up the condensate line size to 1" and terminate condensate discharge as close to the unit as possible. Longer condensate runs are more prone to freezing. Damages due to frozen or blocked condensate lines ARE NOT covered by warranty.
4. Support of the condensate line may be necessary to avoid blockage of the condensate flow.
5. To allow proper drainage on longer horizontal condensate runs, tubing size may need to increase to 1" and a second line vent may be required.

**NOTE:** To clean out condensate trap, see Maintenance section.

<b>WARNING</b>
Power to the optional condensate pump is continuous. When the boiler is powered off the condensate pump will remain on. It is important to remember to turn off the condensate pump when powering down the boiler. Failure to do so could result in property damage, severe personal injury, or death.
<b>CAUTION</b>
The condensate line must remain unobstructed. If allowed to freeze in the line or obstructed in any other manner, condensate can exit from the boiler tee, resulting in potential water damage to property. When installing a condensate pump, select one approved for use with condensing boilers and furnaces. The condensate pump should have an overflow switch to prevent property damage from spillage. Condensate from the boiler will be slightly acidic (pH from 3.2 to 4.5). Install a neutralizing filter if required by local codes.
It is very important that condensate piping be no smaller than 3/4". Use a tee at the condensate connection with a branch vertically up and open to the atmosphere to prevent a vacuum that could obstruct the flow of condensate from the boiler. To prevent sagging and maintain pitch, condensate piping should be supported with pipe supports.
When installing a condensate pump, select one approved for use with condensing boilers and furnaces. The pump should have an overflow switch to prevent property damage from condensate spillage.

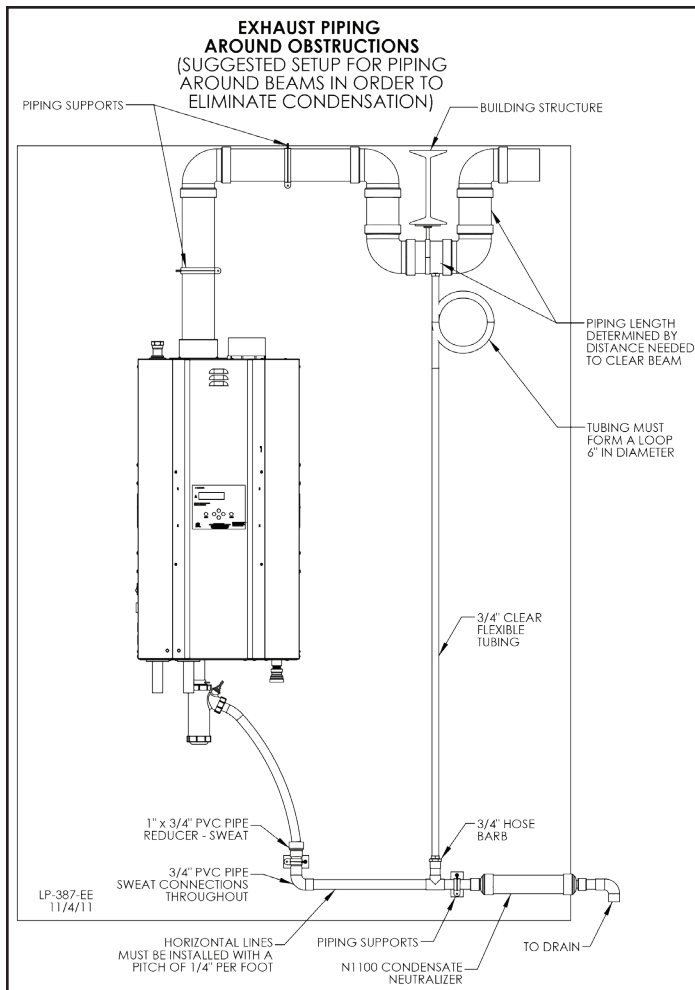

Figure 27 - Piping Exhaust Around Obstructions - Suggested Condensate Removal

## Part 6 - Wiring

### WARNING

To avoid electrical shock, turn off all power to the boiler prior to opening an electrical box within the unit. Ensure the power remains off while any wiring connections are being made. Failure to follow these instructions could result in component or product failure, serious injury, or death. Such product failure IS NOT covered by warranty.

Jumping out control circuits or components WILL VOID product warranty and can result in property damage, personal injury, or death.

It is of extreme importance that this unit be properly grounded. It is very important that the building system ground is inspected by a qualified electrician prior to making this connection. Electrical power must only be turned on when the boiler is completely filled with cold water. Failure to follow these instructions could result in component or product failure, serious injury, or death.

**Electrical Shock Hazard** - Turn off electrical power supply at service entrance panel before making any electrical connections. Failure to follow do do so could result in serious injury, or death.

### CAUTION

Label all wires prior to disconnecting them when servicing the boiler. Wiring errors can cause improper and dangerous operation. Failure to follow these instructions may result in property damage or personal injury.

### CAUTION

Wiring must be NEC Class 1. If original wiring supplied with the boiler must be replaced, use only TEW 105 °C wire or equivalent. Boiler must be electrically grounded as required by the National Electrical Code, ANSI/NFPA 70 - Latest Edition.

#### A. Installation Must Comply With

1. National Electrical Code and any other national, state, provincial, or local codes or regulations.
2. In Canada, CSA C22.1, Canadian Electrical Code Part 1, and any local codes.

#### B. Field Wiring Terminations

All connections made to the boiler in the field are done inside the electrical junction box located on the left side of the unit. Multiple knockout locations are available to route field wires into and out of the electrical junction box.

#### C. Field Wiring

The control used in the boiler is capable of directly controlling 1 pump in standard mode and 2 pumps

when configured as a cascade master boiler. As a standard unit, each pump can provide a maximum of 4 amps at 120 volts. If a pump requires more than this amount of power, an external contactor or motor starter is needed. If the boiler is configured as a cascade master, the system pump output is a dry contact output capable of switching 5 amps at 120 volts, in addition to the boiler pump output sourcing 4 amps each. The electrical junction box has separate, clearly marked terminal strips for line voltage and low voltage wiring. Special jacks are provided for trouble-free cascade system wiring using standard CAT3 or CAT5 patch cables.

**NOTE:** If local electrical codes or conditions require an additional service switch, the installer must provide and install a fused disconnect or 15 amp (minimum) service switch.

#### D. Line Voltage Wiring for Standard Boiler

**NOTE:** A termination plug is included in the CAT 3 / CAT 5 Bus Connection Point, labeled J3 in Figure 29. DO NOT REMOVE THIS PLUG! Doing so will affect boiler operation and void warranty.

1. Connect the incoming power wiring to the line voltage terminal strip in the electrical junction box at terminals 120V, Neutral, Ground (shown in Figure 29).
2. A line voltage fused disconnect switch may be required, externally mounted and connected according to local codes that may apply.
3. Connect the boiler pump as shown in Figure 29 to the terminals marked 1 – (HOT), 2 – (NEUT), and 3 – (GND). The

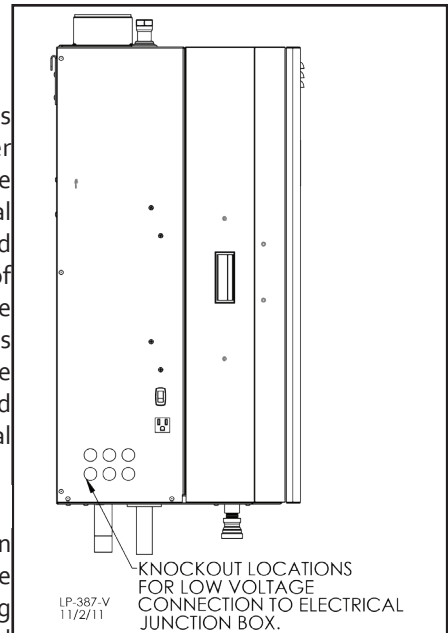

Figure 28 - Knockout Locations

connections shown are suitable for a maximum continuous pump draw of 3 amps at 120 volts. If the pump requires more current or voltage than the 120 volts supplied, an external motor starter or contactor will be required.

**E. Alarm Connections**

The control includes a dry contact alarm output. This is an SPDT circuit, rated at 5 amps at 120 volts. This contact can be used to activate an alarm light or bell or notify a building management system if the boiler goes into a lockout condition. The circuit between the ALARM COM and NC terminals is closed during normal operation and the circuit between ALARM COM and NO is open during normal operation. The connections depicted in Figure 29 show two 120 volt lights connected to the alarm terminals. One light will be on when the boiler is in normal mode and the other light will be on when the boiler is in lockout mode.

**F. Low Voltage Connections for Standard Boiler**

1. All low voltage cables should enter the electrical junction box through the provided knock out holes as shown in Figure 28.
2. Connect all low voltage field devices to the low voltage terminal strip located in the electrical junction box.

**G. Thermostat**

1. Connect the room thermostat to the terminals marked THERMOSTAT in the electrical junction box (see Figures 29 and 32). Alternately, any dry contact closure across these terminals will cause the boiler to run. Take caution to ensure neither of the terminals becomes connected to ground.
2. Mount the thermostat on an inside wall as central as possible to the area being heated, but away from drafts or heat producing devices such as television sets that could influence the ability of the thermostat to measure room temperature.
3. If the thermostat is equipped with an anticipator and it is connected directly to the boiler, the anticipator should be set at .1 amps. If the thermostat is connected to other device(s), the anticipator should be set to match the power requirements of the device(s). See the instruction manual of the connected device(s) for further information.

**H. Outdoor Sensor**

There is no connection required if an outdoor sensor is not used or the system requires a fixed operating temperature.

1. Use a minimum 22 AWG wire for runs of 100 feet or less and minimum 18 AWG wire for runs of up to 150 feet.
2. Mount the outdoor sensor on an exterior surface of the building, preferably on the north side in an area that will not be affected by direct sunlight and will be exposed to varying weather conditions.

**NOTE:** For correct mounting procedures, follow instructions provided with the sensor.

**NOTE:** If sensor wires are located in an area with sources of potential electromagnetic interference (EMI), the sensor wires should be shielded, or the wires routed in a grounded metal conduit. If using shielded cable, the shielding should be connected to the common ground of the boiler.

**I. Indirect Sensor**

There is no connection required if an indirect water heater is not used in the installation.

1. The boiler will operate an indirect fired water heater with either a thermostat type aquastat installed in the indirect

tank or an HTP 7250P-325 tank sensor. When a tank sensor is used, the boiler control will automatically detect its presence and a demand for heat from the indirect water heater will be generated when the tank temperature falls below the user set point by more than the user selectable offset. The demand will continue until the sensor measures that the indirect water heater temperature is above the set point.

2. Connect the indirect sensor (7250P-325) to the terminals marked DHW SENSOR (shown in Figures 29 and 32) in the electrical junction box.

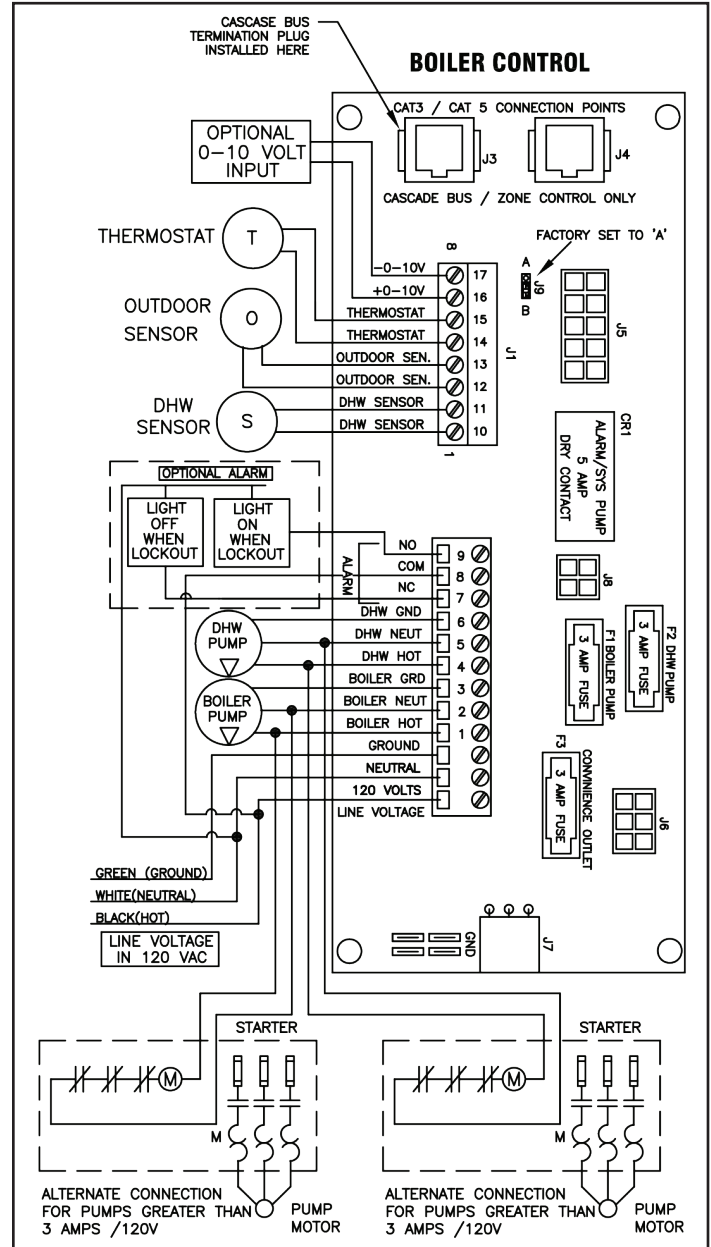

Figure 29 - Control Wiring

**WARNING**

Failure to use the correct sensor may result in tank temperature being either above or below set point, and could result in decreased performance, substantial property damage, or heightened risk of injuries due to scalds.

Caution should be used to ensure neither of these terminals becomes connected to ground. Failure to do so can result in property damage, personal injury, or death.

**NOTE:** If sensor wires are located in an area with sources of potential electromagnetic interference (EMI), the sensor wires should be shielded, or the wires routed in a grounded metal conduit. If using shielded cable, the shielding should be connected to the common ground of the boiler.

**J. Optional 0-10 Volt Building Control Signal**

1. A signal from a building management system may be connected to the boiler to enable remote control. This signal should be a 0-10 volt positive-going DC signal. When this input is enabled using the installer menu, a building control system can be used to control the set point temperature of the boiler. The control interprets the 0-10 volt signal as follows; when the signal is between 0 and 1.5 volts, the boiler will be in stand-by mode, not firing. When the signal rises above 1.5 volts, the boiler will ignite. As the signal continues to rise towards its maximum of 10 volts, the boiler will increase in set point temperature. See Part 10 for details on the setting of function 16.

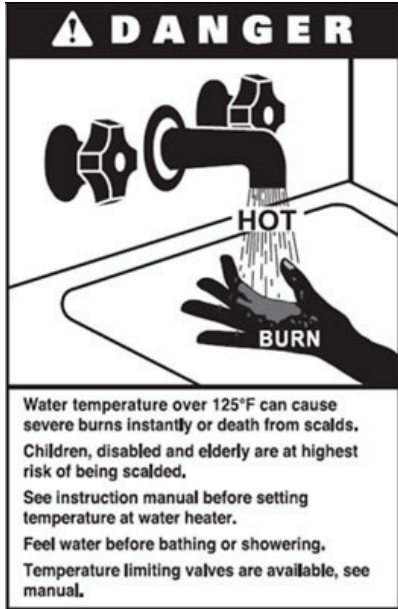

2. Connect a building management system or other auxiliary control signal to the terminals marked 16, 0-10 VOLT + and 17, 0-10 VOLT – in the electrical junction box (shown in Figure 29). Caution should be used to ensure that the 0-10 VOLT + connection does not become connected to ground.
3. Move jumper on connection board (shown in Figure 31) from A to B.
4. See Function 17 this manual to program the 0-10 volt signal.

**NOTE:** When a 0-10 volt building management system is installed, the return sensor temperature cannot be monitored through the appliance display.

**NOTE:** Ensure that the polarity of the connections from the external modulating boiler controller to the boiler is correct. Reversed polarity could lead to erratic and/or no response from the boiler controller.

**K. Optional UL353 Low Water Cut-Off Interface Kit**

If an optional UL 353 Low Water Cut-Off (LWCO) Interface Kit is used, the control box of the kit should be mounted to the left side of the boiler cabinet near the low water cut-off probe, which is located on the outlet nipple of the boiler.

Follow the complete instructions included in the kit for proper installation.

**NOTE:** The control system senses system water temperatures entering and exiting the heat exchanger to provide protection against low water conditions. Where local codes or jurisdictions do not accept a pressure device for low water protection, the jurisdictions may accept these control functions as a means of providing low water protection.

**L. Wiring of Cascade System Communication Bus**

1. A Cascade Bus Termination Plug has been installed on the customer connection board of this boiler. The purpose of this plug is to stabilize communication between multiple boilers and reduce electrical “noise”. See Figures 30 and 31 for Cascade Bus Termination Plug installation detail.
2. Use standard CAT3 or CAT5 computer network patch cables to connect the communication bus between each of the boilers. These cables are readily available at any office supply, computer, electronic, department or discount home supply store in varying lengths. If you possess the skills you can also construct custom length cables.
3. It is recommended to use the shortest length cable that will reach between the boilers and create a neat installation. Do not run unprotected cables across the floor where they may become wet or damaged. Avoid running communication cables parallel and close to or against high voltage (120 volt or greater) wiring. HTP recommends that the maximum length of communication bus cables not exceed 200 feet.
4. Route the communication cables through one of the knockouts in the cabinet.

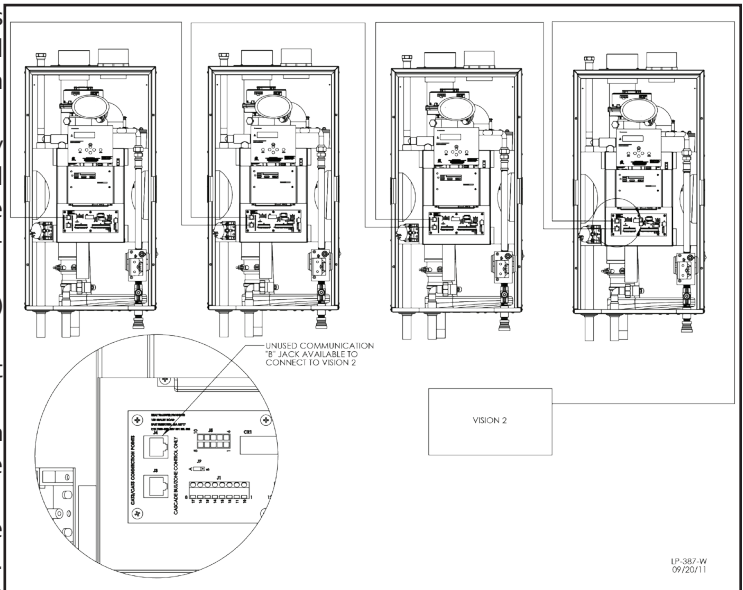

Figure 30 - Wiring Cascade System

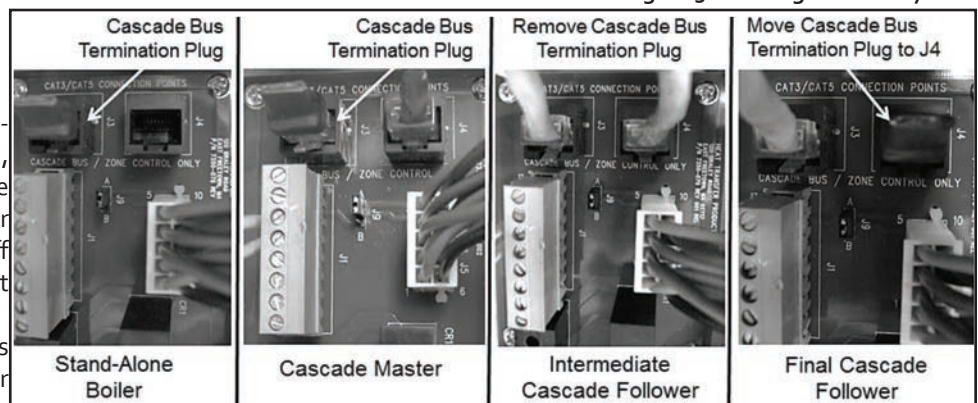

Figure 31 - Cascade Termination Plug Detail



5. Connect the boilers in a daisy chain configuration as shown below. It is best to wire the boilers using the shortest wire runs rather than trying to wire them in the order that they are addressed. The communication bus jacks on the customer connection panel are interchangeable so you can use either one or both in any order to connect the cable.

If you have connected the boilers to each other properly, there will be no open communication connection ports.

**M. Cascade Master Pump and Sensor Wiring**

1. Connect the system pump hot wire to the terminal marked 8.
2. Connect the system pump neutral to the 2 terminal and the pump ground wire to the 3 terminal.
3. Connect a jumper wire from the 120 VOLT terminal to the 9 terminal.
4. Connect the boiler pump to the terminals marked 1 (HOT), 2 (NEUT) and 3 (GND).
5. Connect system pipe sensor to terminals marked 10 and 11.

**N. Cascade Follower Pump and Sensor Wiring**

1. Connect the boiler pump to the terminals labeled 1 (HOT), 2

(NEUT), and 3 (GND).

2. An alarm bell or light can be connected to the alarm contacts of the follower boiler. The normally closed alarm contact may be used to turn a device off if the boiler goes into lockout mode. The alarm contacts are rated 5 amps at 120 VAC.

To connect an alarm device, connect the power for the device to the ALARM COM terminal. Connect the alarm device hot wire to the ALARM NO terminal. Connect the neutral or return of the alarm device to the neutral or return of the power for the alarm device.

To connect a device that should be powered off during a boiler lockout condition, follow the same instructions as above except use the ALARM NC terminal rather than the ALARM NO terminal.

Note that in a cascade system the alarm output of the boiler addressed as #1 will also be active if the master boiler has a lockout condition. The alarm output of boilers addressed as 2-7 will only activate an alarm if a lockout condition occurs on that specific boiler.

See Figure 32 for Cascade Master and Follower Wiring detail.

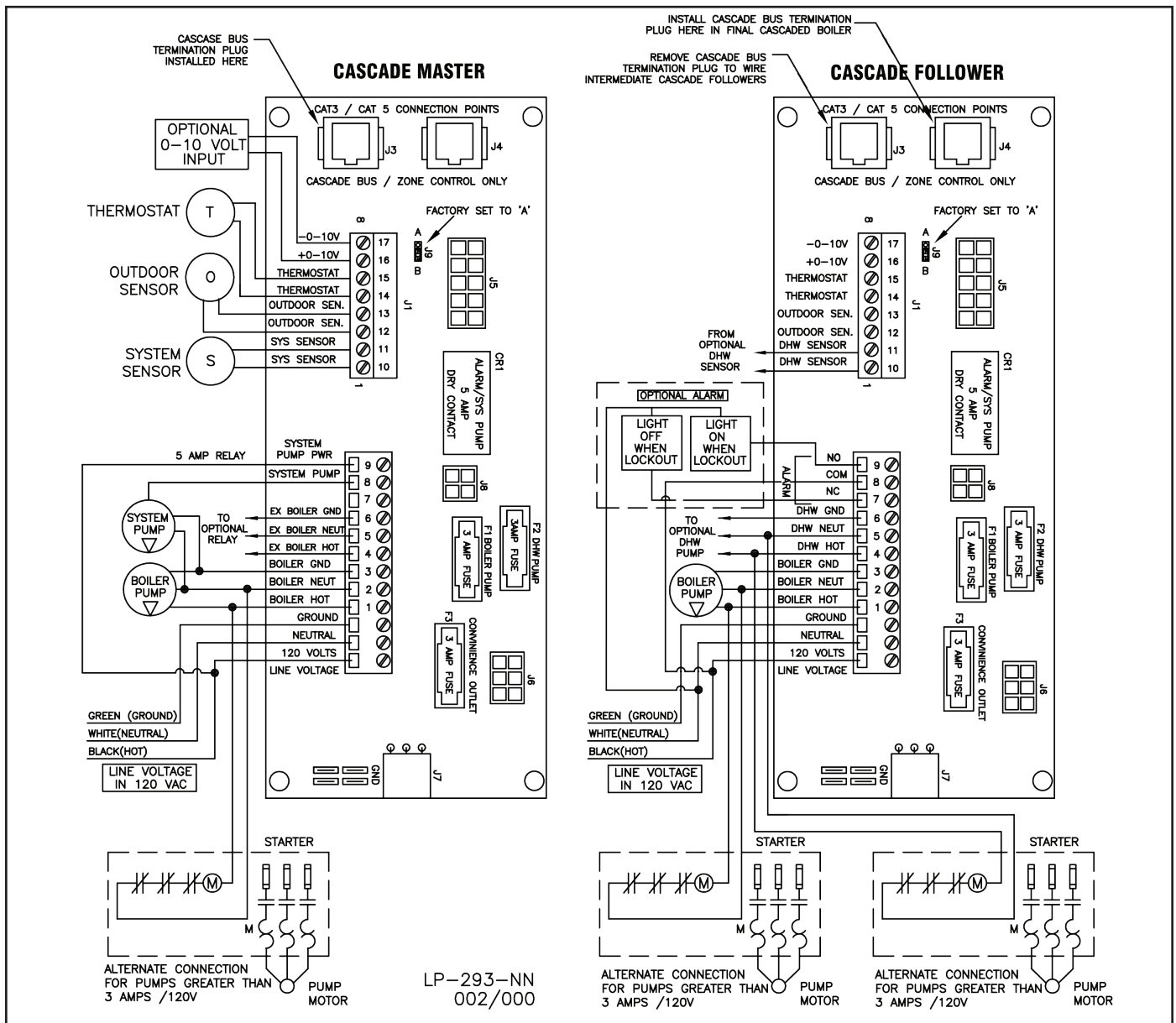

Figure 32 - Cascade Master and Follower Wiring

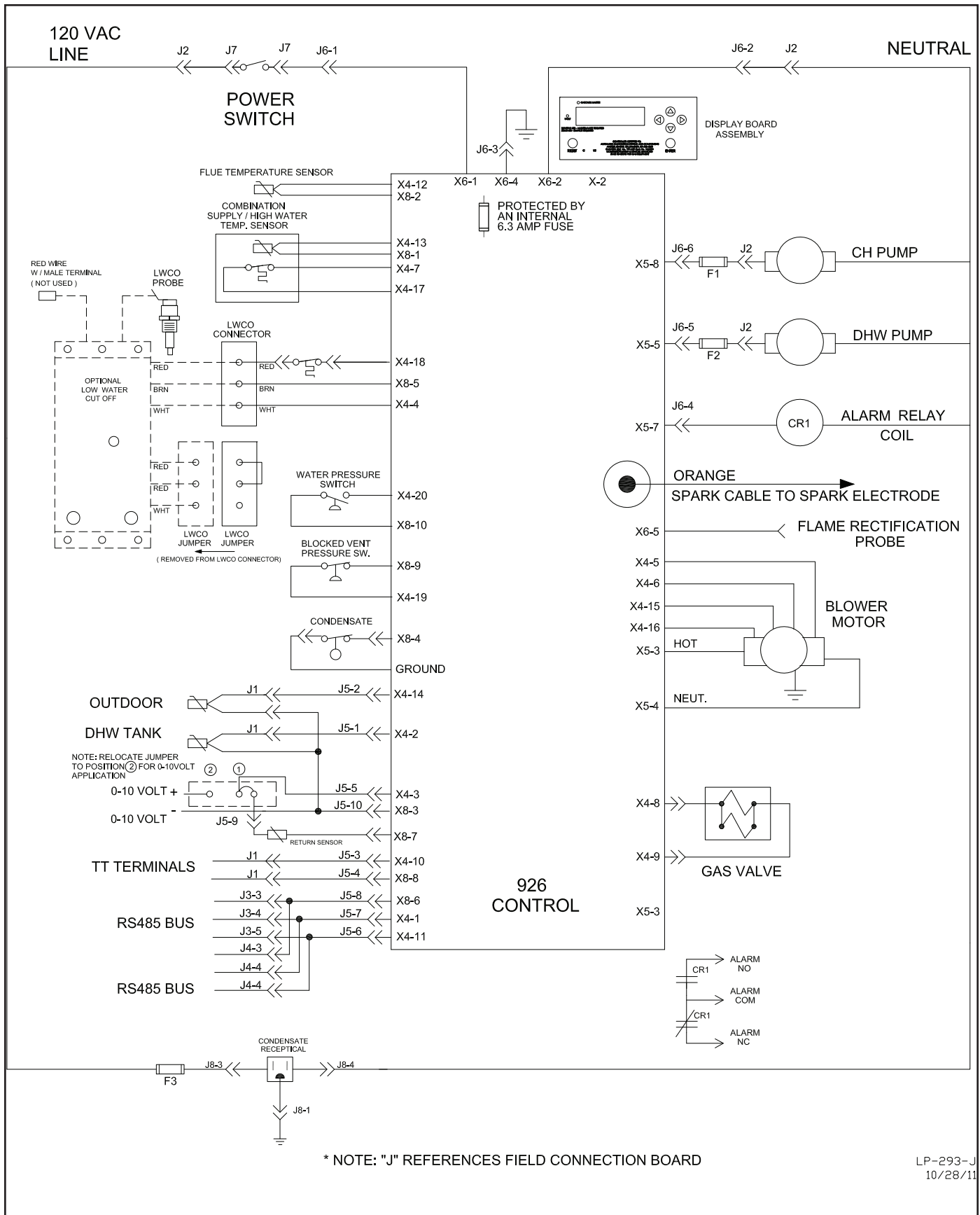

Figure 33 - Internal Connection Diagram

## Part 7 - Gas Connections

### **WARNING**

Failure to follow all precautions could result in fire, explosion, severe injury, or death.

It is very important that you are connected to the type of gas noted on the rating plate. "LP" for liquefied petroleum, propane gas, or "NG" for natural or city gas. Do not do a gas conversion without an approved gas conversion kit. Prior to turning the gas on, all gas connections must be approved by the local gas supplier or utility, in addition to the governing authority.

A gas conversion kit comes with the boiler. Follow the included instructions VERY carefully if converting the boiler. Failure to follow gas conversion instructions could result in property damage, serious injury, or death.

The gas supply shall have a maximum inlet pressure of less than 14" w.c. (3.5 kPa), and a minimum of 3.5" w.c. (.87 kPa). The entire piping system, gas meter and regulator must be sized properly to prevent pressure drop greater than 0.5" (.12 kPa) as stated in the National Fuel Gas Code. This information is listed on the rating label.

### **WARNING**

UL recognized fuel gas detectors are recommended in all enclosed propane and natural gas applications where there is a potential for an explosive mixture of fuel gas to accumulate. The installation of these detectors should be made in accordance with the detector manufacturer's recommendations, and/or local laws. Failure to install fuel gas detectors in these applications could result in fire, explosion, property damage, severe personal injury, or death.

The gas connection on the boiler is 3/4". It is mandatory that this fitting is used for connection to a field fabricated drip leg as shown in the illustration per the National Fuel Gas Code. You must ensure that the entire gas line to the connection at the boiler is no smaller than the unit supplied connection.

Once all inspections have been performed, the piping must be leak tested. If the leak test requirement is a higher test pressure than the maximum inlet pressure, you must isolate the boiler from the gas line. In order to do this, shut the gas off using factory and field-installed gas cocks. This will prevent high pressure. Failure to do so may damage the gas valve. In the event the gas valve is exposed to a pressure greater than 1/2 PSI, 14" w.c. (3.5 kPa), the gas valve must be replaced. Never use an open flame (match, lighter, etc.) to check gas connections.

### A. Gas Piping

1. Run the gas supply line in accordance with all applicable codes.
2. Locate and install manual shutoff valves in accordance with state and local requirements.
3. In Canada, the Manual Shutoff must be identified by the installing contractor.
4. It is important to support gas piping as the unit is not designed to structurally support a large amount of weight.
5. Purge all gas lines thoroughly to avoid start up issues with air in the lines.

6. Sealing compound must be approved for gas connections. Care must be taken when applying compound to prevent blockage or obstruction of gas flow which may affect the operation of the unit.

### **WARNING**

Support gas supply piping with hangers, not by the boiler or its accessories. The boiler gas valve and blower will not support the weight of the piping. Make sure the gas piping is protected from physical damage and freezing, where required. Failure to follow these instructions could result in gas leakage, and result in fire, explosion, property damage, severe personal injury, or death.

Do not use Teflon tape on gas line pipe thread. Use a pipe compound rated for use with natural and propane gases. Apply sparingly on male pipe ends, leaving the two end threads bare and flow unobstructed. Failure to follow these instructions could result in gas leakage or blockage, and result in fire, explosion, property damage, severe personal injury, or death.

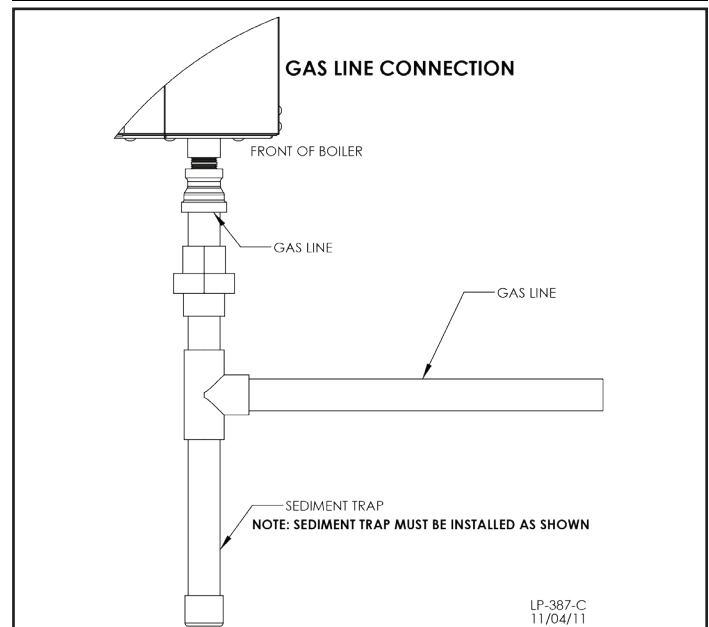

Figure 34 - Gas Connection

### **WARNING**

#### Breathing Hazard - Carbon Monoxide Gas



- Do not operate heater if flood damaged.
- Install vent system in accordance with local codes and manufacturers installation instructions.
- Do not obstruct heater air intake or exhaust. Support all vent piping per manufacturers installation instructions.
- Do not place chemical vapor emitting products near unit.
- According to NFPA 720, carbon monoxide detectors should be installed outside each sleeping area.
- Never operate the heater unless it is vented to the outdoors.
- Analyze the entire vent system to make sure that condensate will not become trapped in a section of vent pipe and therefore reduce the open cross sectional area of the vent.

LP-304-FR

**Breathing carbon monoxide can cause brain damage or death. Always read and understand instruction manual.**

**▲ WARNING**

Never use an open flame (match or lighter) to check for gas leaks. Use a soapy solution to test connection. Failure to use a soapy solution test or check gas connection for leaks can result in substantial property damage, severe personal injury, or death.

**CAUTION**

Use two wrenches when tightening gas piping at the boiler: One to prevent the boiler gas line from turning. Failure to prevent the boiler gas connection from turning could result in damage to the gas line components, substantial property damage, severe personal injury, or death.

CSA or UL listed flexible gas connections can be used when installing the boiler. Flexible gas connections have different capacities and must be sized correctly for the connected boiler firing rates. Consult with the flex line supplier to assure the line size is adequate for the job. Follow local codes for proper installation and service requirements.

**B. Check Inlet Gas Pressure**

The gas valve is equipped with an inlet gas pressure tap that can be used to measure the gas pressure to the unit. To check gas pressure, perform the steps listed below:

1. **IMPORTANT!** Before you connect to the inlet pressure, shut off the gas and electrical power to unit.
2. Loosen the pressure tap with a small screwdriver. Refer to Figure 35 for location.
3. Each unit is equipped with a needle valve that will accept a 5/16 ID hose to connect to a digital manometer or liquid gauge to measure incoming pressure from 0-35" w.c. See Figure 35.
4. Turn on the gas and power up the unit.
5. Put the unit into manual test mode (details on test mode are in Part 10). In test mode, monitor pressure to assure it does not drop below 1 inch from its idle reading. If gas pressure is out of range or pressure drop is excessive, contact the gas utility, gas supplier, qualified installer, or service agency to determine correct action that is needed to provide proper gas pressure to the unit. If Gas Pressure is within normal range proceed to Step 6.
6. Exit test mode, then turn power off and shut off gas supply at the manual gas valve before disconnecting the hose from the gas monitoring device. Tighten screw on the pressure tap and turn gas on. Check for leaks with soapy solution. Bubbles will appear on the pipe to indicate a leak is present.

Nominal Iron Pipe Size (inches)	Internal Diameter (inches)	Length of Pipe (Feet)								
		10	20	30	40	50	60	70		
3/4	.824	278	190	152	130	115	105	96	} BTU'S PER HOUR x1,000	
1	1.049	520	350	285	245	215	195	180		
1 1/4	1.380	1,050	730	590	500	440	400	370		
1 1/2	1.610	1,600	1,100	890	760	670	610	560		
		80	90	100	125	150	175	200		
3/4	.824	90	84	79	72	64	59	55	} BTU'S PER HOUR x1,000	
1	1.049	170	160	150	130	120	110	100		
1 1/4	1.380	350	320	305	275	250	225	210		
1 1/2	1.610	530	490	460	410	380	350	320		

Table 13 - Gas Pipe Sizing / BTU's per Hour

**▲ WARNING**

Ensure the pressure tap screw is properly tightened to prevent gas leaks. Failure to do so could cause substantial property damage, severe personal injury, or death.

The gas piping must be sized for the proper flow and length of pipe to avoid pressure drop. The gas meter and regulator must be properly sized for the total gas load. If you experience a pressure drop greater than 1" w.c. (.87 kPa), the meter, regulator or gas line may be undersized or in need of service. You can attach a manometer to the incoming gas drip leg after removing the cap. The gas pressure must remain between 3.5" (.87 kPa) and 14" (3.5 kPa) during stand-by (static) mode and while in operating (dynamic) mode.

If an in-line regulator is used, it must be a minimum of 10 feet from the boiler. It is very important that the gas line is properly purged by the gas supplier or utility. Failure to properly purge the lines, or improper line sizing, will result in ignition failure. This problem is especially noticeable in NEW LP installations and empty tank situations. This situation can also occur when a utility company shuts off service to an area to provide maintenance to their lines. This gas valve must not be replaced with a conventional gas valve under any circumstances.

**▲ WARNING**

Gas conversion should be performed BEFORE the boiler is installed. Carefully follow the gas conversion instructions when performing the conversion.

Do not do a gas conversion on this boiler without an officially approved conversion kit and instructions supplied by HTP. Failure to use a conversion kit when converting the boiler to fire on Natural or Propane gas will result in extremely dangerous burner operation, leading to fire, explosion, severe personal injury, or death.

Strain on the gas valve and fittings may result in vibration, premature component failure and gas leakage, and result in fire, explosion, property damage, severe personal injury, or death.

Adjustments to the throttle screw or offset may only be made by a qualified gas technician using a calibrated combustion analyzer capable of measuring CO<sub>2</sub> and CO. Failure to follow this instruction could result in fire, explosion, property damage, severe personal injury, or death.

DO NOT adjust or attempt to measure gas valve outlet pressure. The gas valve is factory-set for the correct outlet pressure and requires no field adjustment. Attempts by the installer to adjust or measure the gas valve outlet pressure could result in damage to the valve and cause substantial property damage, severe personal injury, or death.

Ensure that the high gas pressure regulator is as least 6 – 10 feet upstream of the appliance. Failure to do so could result in substantial property damage, severe personal injury, or death.

### C. Boiler Gas Valve

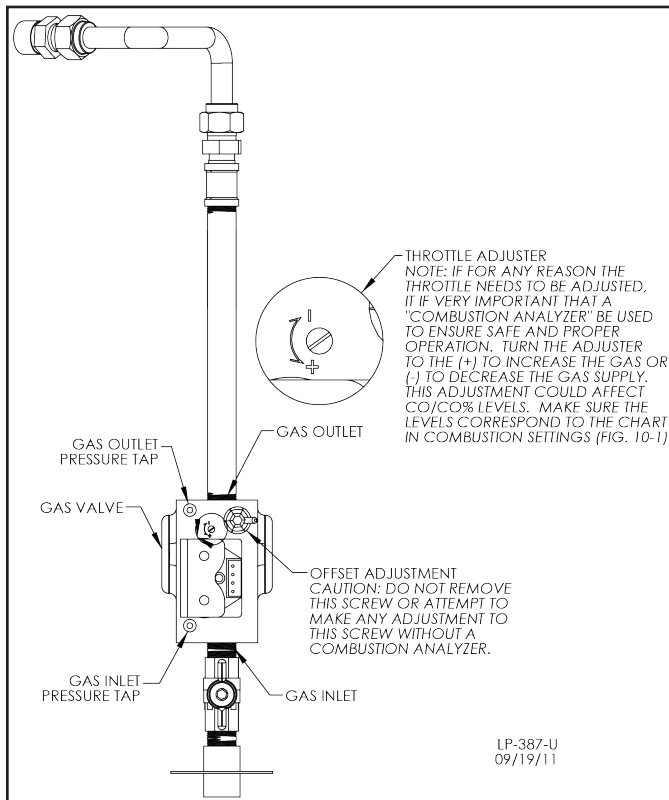

Figure 35 - Gas Valve

## Part 8 - Start-Up Preparation

### WARNING

Thoroughly clean and flush any system that has used glycol before installing the boiler. Provide the customer with a material safety data sheet (MSDS) on the fluid used.

### A. Check / Control Water Chemistry

#### CAUTION

Chemical imbalance of your water can cause severe damage to your boiler and associated equipment, and may also affect efficiency. You may have to have your water quality professionally analyzed to determine whether you need to install a water softener. It is important that the water chemistry on both the domestic hot water and central heating sides are checked before installing the boiler, as water quality will affect the reliability of the system. Outlined below are those water quality parameters which need to be met in order for the system to operate efficiently for many years. Failure of a heat exchanger due to lime scale build-up on the heating surface, low pH or other imbalance IS NOT covered by the warranty.

To assure extended service life, it is recommended to test water quality prior to installation. Listed below are some guidelines.

#### CAUTION

Do not use petroleum-based cleaning or sealing compounds in the boiler system. Damage to elastomer seals and gaskets in the system could occur, resulting in substantial property damage.

**Sodium less than 20 mGL**

**Water pH between 6.0 and 8.0**

1. Maintain boiler water pH between 6.0 and 8.0. Check with litmus paper or have it chemically analyzed by a water treatment company.
2. If the pH differs from above, consult local water treatment company for treatment needed.

**Hardness less than 7 grains**

Consult local water treatment companies for unusually hard water areas (above 7 grains hardness).

**Chlorine concentration less than 100 ppm**

1. Using chlorinated fresh water should be acceptable since drinking water chlorine levels are typically less than 5 ppm.
2. Do not connect the boiler to directly heat a swimming pool or spa water.
3. Do not fill boiler or operate with water containing chlorine in excess of 100 ppm.

**Hardness:** Less than 7 grains

**Chloride levels:** Less than 100 ppm

**pH levels:** 6 - 8

**Conductivity:** Less than 400 uS/cm at 25°C

**Sodium:** Less than 20 mGL

**Copper:** Less than 0.1 mg/

**Iron:** Less than 0.5 mg/L

### Clean system to remove sediment\*

1. You must thoroughly flush the system (without boiler connected) to remove sediment. The high-efficiency heat exchanger can be damaged by buildup or corrosion due to sediment.
2. For zoned systems, flush each zone separately through a purge valve. (If purge valves and isolation valves are not already installed, install them to properly clean the system.)
3. Flush system until water runs clean and you are sure piping is free of sediment.

**\*NOTE:** It is recommended you clean heat exchanger at least once a year to prevent lime scale buildup. Follow the maintenance procedure to clean the heat exchanger in the Maintenance Section of this manual.

### Test/replace freeze protection fluid

1. For systems using freeze protection fluids, follow fluid manufacturer's instructions to verify inhibitor level and that other fluid characteristics are satisfactory.
2. Freeze protection fluid must be replaced periodically due to degradation of inhibitors over time. Follow all fluid manufacturer instructions.

**NOTE: Boiler failure due to improper water chemistry is not covered by warranty.**

### B. Check for Gas Leaks

#### WARNING

Before starting the boiler, and during initial operation, smell near the floor and around the boiler for gas odorant or any unusual odor. Remove boiler front door and smell interior of boiler enclosure. Do not proceed with startup if there is any indication of a gas leak. Repair any leaks at once.

### **WARNING**

PROPANE BOILERS ONLY – The propane supplier mixes an odorant with the propane to make its presence detectable. In some instances the odorant can fade, and the gas may no longer have an odor. Before startup (and periodically thereafter), have the propane supplier verify the correct odorant level in the gas.

#### C. Freeze Protection (When Used)

### **WARNING**

NEVER use automotive or standard glycol antifreeze. Do not use ethylene glycol made for hydronic systems. Use only freeze-protection fluids certified by fluid manufacturer as suitable for use with stainless steel boilers, verified in the fluid manufacturer's literature. Thoroughly clean and flush any system that has used glycol before installing the new boiler. Provide the boiler owner with a material safety data sheet (MSDS) on the fluid used.

1. Determine the freeze protection fluid quantity using total system water content following the fluid manufacturer's instructions. Remember to include expansion tank water content.
2. Local codes may require back flow preventer or actual disconnect from city water supply.
3. When using freeze protection fluid with automatic fill, install a water meter to monitor water makeup. Freeze protection fluid may leak before the water begins to leak, causing concentration to drop, reducing the freeze protection level.

#### D. Fill and Test Water System

### **WARNING**

Ensure the boiler is full of water before firing the burner. Failure to do so will damage the boiler. Such damage IS NOT covered by warranty, and could result in property damage, severe personal injury, or death.

1. Fill the system only after ensuring water chemistry meets the requirements listed in this manual.
2. Close the manual and automatic air vents and boiler drain valve.
3. Fill to the correct system pressure. Correct pressure will vary with each application.
  - a. Typical cold water fill pressure for a residential system is 12 psi.
  - b. Pressure will rise when boiler is turned on and system water temperature increases. Operating pressure must never exceed the relief valve pressure setting.
4. At initial fill and during boiler startup and testing, check system thoroughly for leaks. Repair all leaks before proceeding further.

### **WARNING**

Eliminate all system leaks. Continual fresh make-up water will reduce boiler life. Minerals can build up in the heat exchanger, reducing heat transfer, overheating the heat exchanger and causing heat exchanger failure.

5. The system may have residual substances that could affect water chemistry. After the system has been filled and leak tested, verify that water pH and chlorine concentrations are

acceptable by sample testing.

### **CAUTION**

It is important to purge the system of air to avoid damage to the boiler.

#### E. Purge Air from Water System

1. Purge air from the system:
  - a. Connect a hose to the purge valve and route hose to an area where water can drain and be seen.
  - b. Close the boiler or system isolation valve between the purge valve and fill connection to the system.
  - c. Close zone isolation valves.
  - d. Open quick-fill valve on cold water make-up line.
  - e. Open purge valve.
  - f. Open the isolation valves one zone at a time. Allow water to run through the zone, pushing out the air. Run water until no noticeable air flow is present. Close the zone isolation valves and proceed with the next zone. Follow this procedure until all zones are purged.
  - g. Close the quick-fill water valve and purge valve and remove the hose. Open all isolation valves. Watch the system pressure rise to correct cold-fill pressure. It is recommended that you put the pumps into manual operation to assist in purging the circuits.
  - h. Disconnect the wires that are connected to the THERMOSTAT terminals of the customer connection board. Apply power to the boiler. The display will show the temperature of the water in the boiler. Press the **v** and **ENTER** keys simultaneously and hold for 1 second. The display will read:

```
SERVICE PUMP CH
PUMP ON          11:47A
```

The central heating pump will come on. If you then press the **^** key, the central heating pump will shut off. The display will read:

```
SERVICE PUMP DH
PUMP ON          11:47A
```

The DHW pump will come on. If the boiler is set up as a cascade master and you then press the **^** key again, the DHW pump will shut off. The display will read:

```
SERVICE PUMP SH
PUMP ON          11:47A
```

The system pump will come on. Use the **^** and **v** keys to toggle between running each pump in the system as required to help bleed out all entrapped air. Some good indicators that air is removed include the absence of gurgling noises in the pipes and pump operation becoming very quiet. Pressing **^** and **v** together at any time will return the boiler to normal operation.

- i. After the system has operated for five minutes, eliminate any residual air by using the manual air vents located throughout the system.
- j. If purge valves are not installed in the system, open manual air vents in the system one at a time, beginning with the lowest floor. Close vent when water squirts out. Repeat with

- remaining vents.
- k. Refill to correct pressure.

### F. Check Thermostat Circuit(s)

1. Disconnect the two external wires connected to the boiler thermostat terminals (low voltage terminal strip).
2. Connect a voltmeter across these two incoming wires with power supplied to the thermostat circuits. Close each thermostat, zone valve and relay in the external circuit one at a time and check the voltmeter reading across the incoming wires.
3. There should NEVER be a voltage reading.
4. If a voltage reading does occur under any condition, check and correct the external wiring. (This is a common problem when using 3-wire zone valves.)
5. Once the external thermostat circuit wiring is checked and corrected if necessary, reconnect the external thermostat circuit wires to the boiler low voltage terminal strip. Allow the boiler to cycle.

### G. Condensate Removal

1. The boiler is a high efficiency condensing boiler. Therefore, the unit has a condensate drain. Condensate fluid is nothing more than water vapor, derived from combustion products, similar to that produced by an automobile when it is initially started.

Condensation is slightly acidic (typically with a pH of 3 to 5) and must be piped with the correct materials. Never pipe the condensate using steel, copper, brass or other materials that will be subject to corrosion. Plastic PVC or CPVC pipe are the only approved materials.

A condensate neutralizer, if required by local authorities, can be made up of lime crystals, marble or phosphate chips that will neutralize the condensate. This may be done by the installer or you may purchase a condensate neutralizer from HTP (7450P-212).

2. The boiler is equipped with a  $\frac{3}{4}$  female socket weld fitting connection that must be piped to a local drain. It is very important that the condensate line is sloped downward away from the boiler to a suitable inside drain. If the condensate outlet on the appliance is lower than the drain, you must use a condensate removal pump, available from HTP (554200). This pump is equipped with two leads that can be connected to an alarm or another type of warning device to alert the user of a condensate overflow, which, if not corrected, could cause property damage.
3. If a long horizontal run is used, it may be necessary to create a vent in the horizontal run to prevent a vacuum lock in the condensate line.
4. Do not expose the condensate to freezing temperatures.
5. It is very important you support the condensation line to assure proper drainage.

### H. Final Checks Before Starting Boiler

1. Read Startup Procedures within this manual for proper steps to start boiler. (See Startup Report to record steps for future reference.)
2. Verify the boiler and system are full of water and all system components are correctly set for operation.

## **WARNING**

Ensure the boiler is full of water before firing the burner. Failure to do so will damage the boiler. Such damage IS NOT covered by warranty, and could result in property damage, severe personal injury, or death.

3. Fill condensate trap with water.
4. Verify electrical connections are correct and securely attached.
5. Inspect exhaust vent and intake piping for signs of deterioration from corrosion, physical damage or sagging. Verify exhaust vent and intake piping are intact and correctly installed per Venting Section and local codes.

### I. Setting Up a Single Boiler

When power is applied to the boiler, the control first completes a power-up systems check. During this time the combustion fan may run. The display will initially show the current boiler supply temperature. If a fault is detected during the power-up test, the control will display the appropriate fault code. Otherwise, the display will continue to show the boiler supply temperature and stand-by, waiting for a demand for heat.

When a demand for heat is received, the control begins the following demand sequence. The boiler first turns on the pump. The control will measure the supply temperature. If it is below the set point temperature minus the ignition differential the control will ignite the burner.

After the burner is lit, the control modulates the firing rate to control the supply water temperature and meet the heat demand. When the thermostat or indirect water heater temperature is met, the control will extinguish the burner and run the combustion fan to purge gasses from the combustion chamber. In addition, the pump will run for a pump post purge interval. The control will then be in standby, waiting to process the next demand for heat.

During this process, the control will extinguish the burner if it senses a dangerous or unsafe condition. If the control determines that a dangerous or unsafe condition has occurred, the control may lock out the boiler and prevent it from igniting until a maintenance person diagnoses the problem, repairs it, and resets the control. In the event that the control goes into lockout, it will show a diagnostic code on the display, illuminate the LED fault indicator, and close the alarm relay contacts to aid in recognition of the condition, diagnosis, and repair.

### J. Setting Up a Cascaded System

If the boiler is part of a cascaded system the operation is somewhat different. The control of each boiler in a cascaded system completes its own power up system check. One of the boilers in the cascade system is designated as the master boiler. After the master boiler completes its power up sequence, it checks the communication bus to see if any other boilers are present. If other boilers are present, the master control determines these follower boiler addresses. The master boiler control will recheck the bus every few seconds as long as it is powered up to update the status of the connected boilers. The control in the master boiler processes all heat demands and dictates which of the follower boilers should light and what firing rate the followers should try to achieve.

When the master boiler receives a demand for heat, it determines which boiler is first in the firing sequence and sends that boiler a command to begin a demand sequence. That boiler will then

begin a demand sequence as described above. Once the boiler ignites, the master boiler control will increase the firing rate command to that boiler until the system sensor temperature is at the set point temperature plus the differential, or that boiler is at high firing rate. If the command from the master boiler control gets to the high firing rate of the follower boiler, but the system sensor is below the required temperature, the master boiler control will then tell the next boiler in the firing sequence to begin its demand sequence. The master boiler control will then begin to ramp up the firing rate command of that boiler. This process will continue while there is a demand until all boilers in the cascade system are at high fire or the desired temperature of the system sensor is reached. If the system sensor temperature reaches tank set point and differential before all boilers are at high fire, the master control will modulate the cascade command signal to maintain the system sensor at set point and differential until the demand is complete. When the system sensor is equal to the set point temperature, demand is complete, and the master boiler control will extinguish all boilers that may be lit. If the demand decreases, the firing rate command and amount of boilers lit will decrease exactly opposite as described above.

Whenever the master boiler control needs to fire a follower boiler, it sends a firing rate command to that boiler. The follower boiler will respond to the command until its supply sensor temperature gets to be 5°F above the set point temperature plus the differential, at which point the individual boiler will modulate on its own so as not to overheat. As a result, it is not uncommon to see the cascade output at maximum but individual boilers firing at less than their maximum firing rate.

#### **K. Lockout Condition**

If any boilers, including the master boiler in the cascade system, are in a lockout condition, the master control will recognize the lockout condition and skip over the boiler in the firing sequence. Each boiler in the cascade system is responsible for its own safety functions. So, if any individual boiler control senses an unsafe condition, it will extinguish the burner and, if necessary, go to a lockout condition. In this way, every boiler in the system has its individual safety controls intact and operational, even if the firing of the boiler is under control of the master boiler.

In the event that the system sensor fails, all boilers in the system will ignite simultaneously when there is a demand, and each boiler will individually regulate firing rates to maintain the master set point temperature (supply temperature set point + differential) at the individual supply sensors built into the boiler. If this should happen, the master boiler will display an E03 fault code, indicating that the supply sensor has failed.

#### **L. Cascade System Programming**

##### **1. If the boiler is used alone, skip this section.**

##### **2. Programming the Master Boiler:**

- a. Make sure there is no demand for heat being supplied to the boiler.
- b. Apply power to the boiler.
- c. Enter the system setting program navigation following instructions in Part 10 of this manual.
- d. Verify that cascade address function 15 is set to 0. This makes the master boiler address 0. NOTE: The Master Boiler MUST be addressed as 0.
- e. Change Cascade Mode function 23 to 926 Boilers. This makes it the master boiler.

- f. Exit the installer menu.

**NOTE:** The temperature set point of the master must match the follower boiler set point in order for the system to operate properly.

##### **3. Programming Follower Boilers:**

##### **NOTE: READ THE NOTES BELOW BEFORE PROGRAMMING FOLLOWER BOILERS**

- The boiler addressed as 1 will share its alarm output with the master boiler.
- If one of the follower boilers has an indirect fired water heater connected to it, the address of this boiler must be 2 or greater.
- It is recommended but not necessary to address boilers in the order that they are wired.
- No two boilers can have the same address.
- It is not required to use all consecutive address numbers. Example: In a 2 boiler system with an indirect connected to the follower, the follower address would be 2 (address 1 is not used).

a. Make sure there is no demand for heat being supplied to the master boiler

b. Apply power to the follower boiler you are working on.

c. Enter system settings following instructions in Part 10 of this manual

d. Set cascade address parameter 15 to 1 for the first follower, 2 for the second follower, etc. depending on which boiler you are programming based on the above notes.

e. Change "CASCADE MODE" parameter to "926 BOILERS". This makes the boiler a follower boiler and enables all data to be transferred between boilers as needed for the system to function to full capability.

f. Exit the installer menu.

**NOTE:** The temperature set point of the follower must match the master boiler set point in order for the system to operate properly.



## Part 9 - Start-Up Procedure

### WARNING

#### FOR YOUR OWN SAFETY READ BEFORE OPERATING

1. This boiler does not have a pilot. It is equipped with an ignition device which automatically lights the burner. Do not try to light the burner by hand.

2. BEFORE OPERATING: Smell all around the boiler area for gas. Be sure to smell next to the floor because some gas is heavier than air and will settle on the floor.

#### 3. WHAT TO DO IF YOU SMELL GAS

- Do not try to light any boiler.
- Do not touch any electric switch, do not use any phone in your building.
- Immediately call your gas supplier from a neighbor's phone. Follow the gas suppliers' instructions.
- If you cannot reach your gas supplier, call the fire department.
- Turn off the gas shutoff valve (located outside the boiler) so that the handle is crosswise to the gas pipe. If the handle will not turn by hand, don't try to force or repair it, call a qualified service technician. Force or attempted repair may result in a fire or explosion.

4. Do not use this boiler if any part has been under water. Immediately call a qualified service technician to inspect the boiler and to replace any part of the control system and any gas control that has been damaged.

5. The boiler shall be installed so the gas ignition system components are protected from water (dripping, spraying, rain, etc.) during boiler operation and service (circulator replacement, condensate trap, control replacement, etc.)

Failure to follow these instructions could result in property damage, serious personal injury, or death.

If you discover any evidence of a gas leak, shut down the boiler at once. Find the leak source with a bubble test and repair immediately. Do not start the boiler again until the leak is repaired. Failure to comply could result in substantial property damage, severe personal injury, or death.

### A. Control Overview

The control is one of the primary safety devices of the boiler. It monitors the safety sensors of the boiler to assure safe and efficient operation.

The control has many features associated with system design. This section addresses programming features, including Boiler Settings / System Settings / Maintenance Settings and System Diagnostics, to help in customizing your control. It is important to fully understand control capabilities before customization, as its factory defaults may already fit your system design and not require any adjustment at all.

### B. Navigation of the Display

The display includes a two line backlit LCD readout to provide informative messages about the operation of the boiler. Many operating parameters can be viewed and adjusted by using the six buttons on the display. The function of each button is described below.

**RESET** – The RESET button has two functions.

- Resets any lockout error code
- Returns the user to the default display screen.

**ENTER** – The ENTER key is used to access parameter programming mode. To access this mode, hold down the ENTER key for more than 4 seconds. The readout will change to:

ENTER MENU CODE 000
------------------------

One of the zeroes will be blinking. Use the  $\wedge$   $\vee$  arrow keys to change the blinking digit to the correct value. Use the  $\lt$   $\gt$  arrow keys to select the next digit to change and again use the  $\wedge$   $\vee$  keys to change the value. Repeat until the correct code is entered. Press the **ENTER** key to accept the code entered. If the code is correct, the readout will change to the appropriate screen. If the programming code is not accepted, the readout will continue to display as shown above.

**ENTER** is also used to enable a function for editing. After the user navigates to the desired function, the user holds down **ENTER** for one second. When **ENTER** is released, the function value will begin to blink. The function can now be changed using the  $\wedge$   $\vee$  keys. After the new value is displayed, the user then presses **ENTER** for 1 second to lock the new value of the function. The value will then stop blinking.

**LEFT AND RIGHT ARROW KEYS** –  $\lt$   $\gt$  are used to navigate between the default display, status display, analog and cascade displays if they are enabled. The  $\lt$   $\gt$  keys are also used in programming modes to change between programmable functions. It is recommended you use the Menu Maps in the back of this manual and the detailed menu instructions printed in this section to help in menu navigation.

**UP AND DOWN ARROW KEYS** –  $\wedge$   $\vee$  are used to navigate between the various functions displayed in the menu. After the function is enabled for editing by pushing the **ENTER** key, the  $\wedge$   $\vee$  keys are used to adjust the function upward or downward to the desired value.

### C. Operating Instructions

Before operating the unit, it is important to remove the cover and verify that the gas line and water lines are connected to boiler and fully purged. If you smell gas, STOP; Follow the safety instructions listed in the first part of this section. If you do not smell gas, follow the next steps.

1. Turn down the thermostats before applying power to the boiler. If 0–10 volt or other inputs are used, make sure that they are set so there is no call for heat while programming.
2. Turn on the power to the boiler or boilers if a cascade system used.
3. Next, check the boiler settings. Adjustment and factory defaults are outlined within this section. If a cascade system is used, it is important that all the boilers have the same boiler settings.
4. Next, check the system settings. Adjustments and factory defaults are outlined within this section. If a cascade system is used, it is important that the Master Boiler is programmed with the correct system settings.
5. Create a demand on the boiler or boilers if a cascade system is used. The user can monitor system functions when the boilers are operational.
6. If the boilers fail to start, refer to the troubleshooting section in the back of this manual.

## D. Programming Boiler Settings

### Boiler Setting Program Access

Note: Programming the boiler control is not possible when the boiler is firing. Make sure any input which can create a demand on the boiler, such as the tank thermostat, is turned off, so the boiler will remain idle to allow programming.

Screen	Description
ENTER MENU CODE 000	To access the boiler setting program, press and hold <b>ENTER</b> for 4 seconds until the display shows the screen at left.
ENTER MENU CODE 600	Use the arrow keys to log in the <b>Boiler Menu Access Code - 600</b> . Press <b>ENTER</b> to confirm the code and access the <b>Boiler Setting Program</b> navigation menu.

Table 14 - Boiler Setting Access

### Boiler Setting Program Navigation

Once the code is confirmed, the user can start to set the **Boiler Settings**. Use the arrow keys on the display to navigate through the **Boiler Settings**. A blinking setting indicates the setting can be changed. To change a setting, press **ENTER**. Boiler settings can be increased by pressing **^** and decreased by pressing **v** on the display. When done, press **ENTER**. The setting will stop blinking and the user can move on to next setting. Press **RESET** to exit programming and store settings. Listed below are the boiler settings that can be programmed into the control.

Screen	Description
CENTRAL HEAT 180 °F	Allows the user to adjust the boiler set point from 50°F to 190°F (Factory Default 180°F).
CENTRAL DIFF SET 30 °F	Adjusts the boiler differential set point from 5°F to 30°F (Factory Default 30°F).
DHW SETPOINT 119 °F	Adjusts the indirect tank set point from 70°F to 185°F (Factory Default 119°F).
DHW DIFF SETPOINT 7 °F	Adjusts the DHW differential set point from 1°F to 30°F (Factory Default 7°F).
TEMP DISPLAY COR F °F	Adjusts the temperature measurement in F = Fahrenheit to C = Celsius (Default is Fahrenheit).

Table 15 - Boiler Setting Program Navigation

### Clock Settings

(NOTE: The clock will reset if the boiler is powered off for more than a week.)

Screen	Description
CLOCK MODE (12/24) 08/28/2009 Fr 9:42A	Changes the clock from 12 hour mode (8:45 PM) to 24 hour mode (20:45). To change to 24 hour mode, press <b>ENTER</b> . The letter (A or P) after the time will blink. Press the up or down arrow key once and the letter will disappear. Press <b>ENTER</b> to save the new setting.
CLOCK HOUR 08/28/2009 Fr 10:01A	Allows the user to adjust the hour setting.

CLOCK MINUTE 08/28/2009 Fr 10:01A	Adjusts the minute setting.
CLOCK DAY OF WEEK 08/28/2009 Fr 10:01A	Adjusts the day of the week.
CLOCK DATE MODE 08/28/2009 Fr 10:01A	Allows the user to switch to European date format (2009/08/28) from US format (08/28/2009).
CLOCK YEAR 08/28/2009 Fr 10:01A	Adjusts the year setting.
CLOCK MONTH 08/28/2009 Fr 10:01A	Adjusts the month setting.
CLOCK DATE 08/28/2009 Fr 10:01A	The clock is set.

Table 16 - Clock Setting Screens

NOTE: The internal clock does not adjust for daylight savings time and requires manual adjustment.

## E. Programming the System Setting

### System Setting Program Access

Note: Programming the boiler control is not possible when the boiler is firing. Make sure any input which can create a demand on the boiler, such as the tank thermostat, is turned off, so the boiler will remain idle to allow programming.

Screen	Description
ENTER MENU CODE 000	To access the boiler setting program, press and hold <b>ENTER</b> for 4 seconds until the display shows the screen at left.
ENTER MENU CODE 925	Use the arrow keys to log in the <b>Boiler Menu Access Code - 925</b> . Press <b>ENTER</b> to confirm the code and access the <b>System Setting Program</b> navigation menu.

Table 17 - System Setting Access

### F. System Setting Program Navigation

Once the **System Menu Access Code** is confirmed, the user can begin to set the system setting menu. Use the **< >** keys on the display to navigate through the System Settings. To change a setting, press **ENTER**. System settings can be **increased** by pressing **^** and **decreased** by pressing **v** on the display. When done, press **ENTER**. The setting will stop blinking and you can move on to next setting. Press **RESET** to exit programming and store settings. Listed below are the boiler settings that can be programmed into the control.

Screen	Description
Function 1	Factory Program Mode
MODE INDIRECT 1	This indicates that the control is configured correctly. Do not change this setting.
Function 3	DHW Tank Max Temp
DHW TANK MAX TEMP 180 °F 3	This is the maximum temperature that can be selected in boiler settings for the DHW indirect tank. Factory Default is 180°F. (Range: 95°F to 180°F)

Screen	Description
<b>Function 6</b>	<b>DHW Post Pump Time</b>
DHW POST PUMP TIME 0 MINUTES 6	The indirect pump has the ability to post purge energy from the boiler to run the pump after the set point has been achieved. Please note that running the pump for a time greater than 5 minutes may cause tank energy to be released back to the boiler heat exchanger. Factory Default of 0 Minutes. (Range: 0 – 10 minutes)
<b>Function 7</b>	<b>Warm Weather Shutoff</b>
WARM WEATHER OFF 68 °F 7	When used with an outdoor sensor, warm weather shut down will disable the boiler if the programmed outdoor temperature is exceeded. Default: 68°F (Range: 41°F to 122°F).
<b>Function 8</b>	<b>Min Outdoor Temp</b>
MIN OUTDOOR TEMP 5 °F 8	Not applicable on this product.
<b>Function 9</b>	<b>Max Supply Temp</b>
MAX SUPPLY TEMP 190 °F 9	Sets the maximum design supply temperature based on the minimum outdoor design temperature. Default: 190°F (Range: 77°F to 190°F).
<b>Function 10</b>	<b>Max Outdoor Temp</b>
MAX OUTDOOR TEMP 68 °F 10	Sets the maximum outdoor design temperature for the system design. Default: 68°F (Range 32°F to 190°F).
<b>Function 11</b>	<b>Min Supply Temp</b>
MIN SUPPLY TEMP 95 °F 11	Sets the design supply water temperature based on the maximum outdoor design temperature. Default: 95°F (Range: 32°F to 190°F).
<b>Function 12</b>	<b>Min Boiler Temp</b>
MIN BOILER TEMP 68 °F 12	Sets the design minimum heat curve temperature for central heat. Default: 68°F (Range: 32°F to 190°F).
<b>Function 13</b>	<b>CH Post Pump Time</b>
CH POST PUMP TIME 0 MINUTES 13	Allows the user to set the boiler pump post purge time once the thermostat is satisfied. Default: 0 minutes (Range: 0 – 10 minutes).
<b>Function 14</b>	<b>DHW Priority</b>
DHW PRIORITY 30 MINUTES 14	Allows the user to set the maximum run time for the indirect fired water heater and the minimum run time for central heating. Default: 30 minutes (Range: 0 – 60 minutes).
<b>Function 15</b>	<b>Cascade Address</b>
CASCADE ADDRESS 0 15	Bus addressing boilers (maximum boilers allowed 8 in a cascade system). Master Boiler address is 0 and Following Boilers are addressed 1 thru 7. Default: 0 (Range: 0 – 8). NOTE: DO NOT USE ADDRESS 8.

Function 16	Optional Inputs
OPTIONAL INPUT RETURN SEN 16	Allows the user to select optional inputs to control or monitor the system. Default: RETURN (Range: Off / Booster Board / 0-10 Volt / DHW Sensor / Return Sen).
<b>Function 17</b>	<b>0-10 Volt Function</b>
0-10 VOLT FUNCTION TEMPERATURE 17	Control boiler modulation through temperature control. Factory Default = Temperature (Range: Temperature or Fan Speed).
<b>Function 18</b>	<b>Step Modulation Mode</b>
STEP MODULATE MODE ON 18	Allows the user to turn ON the step modulation, which regulates burner output in six steps at one minute intervals. Step modulation will start at the last modulation rate of the boiler and work up one minute at a time. Default: OFF (Selection: OFF or ON).
<b>Function 19</b>	<b>Boiler DHW Temp</b>
BOILER SUPPLY DHW 180 °F 19	Allows the user to program the boiler supply water temperature to the indirect heat exchanger during a demand cycle. Default: 180°F (Range: 119°F to 190°F).
<b>Function 20</b>	<b>Water Safety Input</b>
WATER SAFETY INPUT WATER PRESSURE 20	The user can select various water safety inputs used in the boiler system. Default: Flow Switch (Range: None / Low Water Cut Off / Flow Switch / Water Pressure).
<b>Function 21</b>	<b>Error Outdoor Sensor</b>
ERROR OUTD SENSOR OFF 21	Allows the user to set the control to display an error message if an outdoor sensor is open or shorted. NOTE: This error does not stop the boiler from running. Factory Default: ON (Range: ON / OFF / PHOEN ON).
<b>Function 22</b>	<b>Adjust Boiler Output %</b>
ADJ BOILER OUTPUT 100% 22	Adjusts the boiler output down from 100% to 50%. Factory Default: 100%. (Range: 100% – 50%)
<b>Function 23</b>	<b>Cascade Mode</b>
CASCADE MODE VISION 3 23	Allows the user to select cascade mode. Factory Default: Vision 3 (Range: g26 Boilers / Vision 3).
<b>Function 24</b>	<b>Cascade Rotation</b>
CASCADE ROTATION 48 HOURS 24	Sets the amount of hours before the first boiler in the cascade firing rotation will be changed. NOTE: If this is set to 0, the firing order of the boilers will not rotate. Default: 48 hours (Range: 0 – 240 hours).
<b>Function 25</b>	<b>Cascade DHW Mode</b>
NOT USED NOT USED 25	Not applicable on this product.

Screen	Description
<b>Function 26</b>	<b>System Freeze Protection</b>
SYS FREEZE PROT PROTECT OFF 26	<b>NOTE:</b> This parameter is only present if the boiler is a cascade master. Allows the user to set the freeze protection when a system pump is used. Factory Default: OFF. Selection of temperature activates freeze protection. (Range: OFF, -40°F – 104°F).
<b>Function 27</b>	<b>Error System Sensor</b>
ERROR SYSTEM SENS ON 27	Sets the control to display an error message if the system sensor is open or shorted. <b>NOTE:</b> This error does not stop the boiler (or boilers) from running. Factory Default: ON (Range: ON / OFF).
<b>Function 28</b>	<b>Freeze Protection</b>
FREEZE PROTECTION ON 28	Allows the user to set freeze protection on the boiler. Factory Default: ON (Range: ON / OFF).
<b>Function 29</b>	<b>DHW Modulation Mode</b>
DHW MODULATE MODE NORMAL MOD 29	This parameter controls how the boiler modulates for a DHW demand. In NORMAL MOD mode, the boiler will modulate down from high fire when there is a DHW demand. In LOW MOD mode, the boiler will modulate up from low fire when there is a DHW demand. This mode is useful to minimize short cycling when a large boiler and small indirect tank are used together. Factory Default: NORMAL MOD (Range: NORMAL MOD / LOW MOD).
<b>Function 30</b>	<b>Extra Boiler Mode</b>
EXTRA BOILER MODE OFF 30	Allows for a non HTP boiler to be controlled when the cascade output has risen above the percent of the cascade firing rate set in this parameter. Factory Default: Off (Range: 50% - 100%).
<b>Function 31</b>	<b>System Sensor Mode</b>
SYSTEM SENSOR MODE OFF 31	Suppresses the 'NO FOLLOWER' display message if the boiler is used as a cascade master boiler with no follower boilers connected. Factory Default: OFF (Range: ON / OFF).
<b>Function 32</b>	<b>Service Schedule</b>
SERVICE SCHEDULE OFF 32	Selects a service date or time based on the boiler run hours to program the boiler maintenance schedule. Factory Default: OFF (Range: Date or Run Hours). <b>NOTE:</b> Without setting this function, Functions 33/34/35/36 will not display.

Function 37	Modbus Mode
MODBUS MODE OFF 37	Enables Modbus Mode on the appliance. Factory Default: OFF (Range: OFF, ON, AUTO). <b>NOTE:</b> Turning Modbus Mode "ON" will open a number of additional parameters to customize Modbus installation. See Modbus Instructions (lp-372) for details. <b>NOTE:</b> Turning this Mode "ON" without a connected and powered Modbus communication adapter (p/n 7350P-629) will result in improper appliance operation. Service calls associated with this ARE NOT covered by warranty.

**Table 18 - System Setting Program Navigation**

**NOTE:** For the following functions, you must have your maintenance function turned on.

To change these functions, press **ENTER**. The left most digit will begin to blink. Use the **^** or **v** arrows to change the digit. Use the **<** **>** arrow keys to switch between digits. When you've made your selection, press **ENTER** again.

Screen	Description
<b>Function 33</b>	<b>Year</b>
SERVICE SCHEDULE YEAR 00/00/2000 33	Allows the user to set the year of the next service reminder.
	<b>Hours</b>
SERVICE SCHEDULE 10000's 000000 33	Allows the user to set the left two digits of the amount of run hours before next service reminder.
<b>Function 34</b>	<b>Month</b>
SERVICE SCHEDULE MONTH 00/00/2000 34	If the date function was selected, this function programs the month. If you selected the run hour function, you will need to program 10,000 hours, if required.
	<b>Hours</b>
SERVICE SCHEDULE 10000's 000000 34	Allows the user to set the middle two digits of the amount of run hours before next service reminder.
<b>Function 35</b>	<b>Day</b>
SERVICE SCHEDULE DAY 00/00/2000 35	Sets the day of next service reminder.
	<b>Hours</b>
SERVICE SCHEDULE 10000's 000000 35	Sets the two right digits of the amount of run hours for the next service reminder.
<b>Function 36</b>	<b>Telephone</b>
TELEPHONE # 000 000 0000 36	Allows the user to input a telephone number that will display when maintenance is required.

**Table 19 - Maintenance Reminder Function Screens**

### G. Resetting the Maintenance Schedule

When the system control flashes MAINTENANCE REQUIRED, it is advisable that you call for service. After the service is performed, reset the schedule for the next required service by using the following steps.

Press **ENTER** on the display for 3 seconds. The Menu code will

appear as 000. This does not change. Press **ENTER** again. SERVICE SCHEDULE RESET will be displayed. Using the > key scroll to the selection of year or hours. Press **ENTER** to reset the selected Service Schedule. To change a setting, press **ENTER**. Press the ^ and v keys to make adjustments. Press **ENTER** when reset is complete.

**Part 10 - Start-Up Procedures for the Installer**

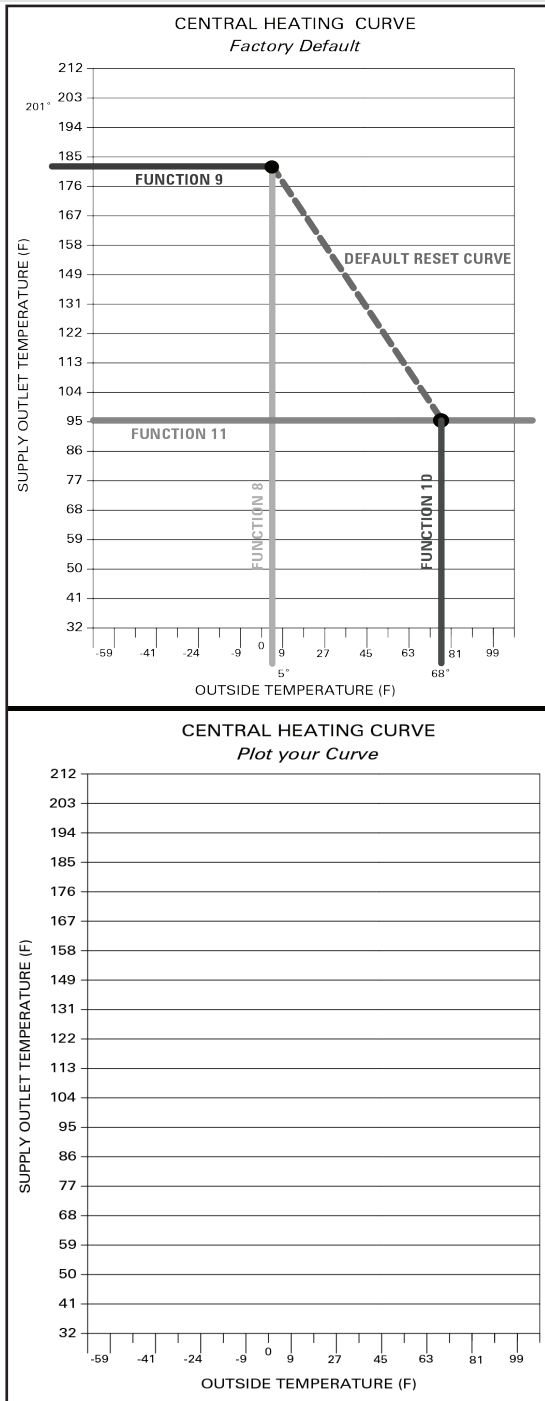

Table 20 - Heating Curve - NOTE: The user can adjust the heat curve down by lowering the central heating temperature.

**A. Boiler Control Status Menu**

The boiler control also has the ability to review system status. To access the status screens, press >. Once the first value is displayed, press ^ and v to scroll through additional information. At any point press **RESET** to exit the status screens.

Screen	Description
SUPPLY SEN RETURN SEN	180°F 150°F This is the first screen that appears after pressing >, and shows the actual temperatures measured by the supply and return sensors. NOTE: If the boiler is configured to use a 0 – 10 volt input, the return sensor is disabled and the second line of the display will be blank.
Press v once.	
CH SET SUPPLY SEN	180°F 122°F The current central heating temperature set point is displayed on the top line. NOTE: This temperature set point may vary from what was set in the boiler settings if an outdoor sensor is used. The actual temperature measured by the supply sensor is displayed on the bottom line.
Press v once.	
CH DEMAND SUPPLY SEN	OFF 122°F This screen displays the central heat demand set for the cascade system.
Press v once.	
0-10 SIGNAL ON *	Shows if 0-10 volt is enabled.
Press v once.	<b>This screen appears only when the boiler is set as a Master Boiler.</b>
CAS SET SYSTEM	190°F 112°F This screen displays the cascade set point (maximum 190°F) on the top line. The system sensor reading is on the second line. The control will cascade the boilers up to this set point depending on demand.
Press v once.	
DHW SET DHW	119°F 117°F Displays the current tank temperature set point on the top line. The actual temperature measured by the tank or return sensor (HTP 7250P-325) is displayed on the bottom line. If a mechanical aquastat is used in place of the recommended sensor, the second line will display 'OFF' in place of the temperature if the aquastat measures close to its set temperature, or 'ON' if the aquastat temperature is too low.
Press v once.	
OUTDOOR FLUE	11°F 95°F The current outdoor temperature is displayed on the top line. If there is no outdoor sensor connected to the boiler, this line will display 'OFF' in place of the temperature. If the outdoor sensor is shorted, this line will display 'ON' in place of the temperature. The second line displays the current flue temperature of the boiler.
Press v once.	
FLAME FAN SPEED	0.00A 3497 RPM This screen displays boiler flame current on the top line. The second line displays boiler fan speed.
Press v once.	

0-10 V BOILER	0.0V	The top line displays the voltage on the optional input. This voltage is only relevant if an external 0-10 volt signal is being used to control the boiler.
<b>Press v once.</b>		
BUS COMM	NO CONN	This display shows the status of the communication bus between multiple boilers. If in a single boiler configuration, the display will show 'NO CONN'. In a multiple boiler configuration, if this is the Master Boiler and other boilers are connected to the communication bus and powered, this screen will show the address of each boiler connected to the bus.
<b>Press v once.</b>		
POWER ON CH ON	0H 0H	The top line indicates the amount of hours the boiler has been powered over its life. The second line indicates how many hours the burner has been on for central heat demand over its life.
<b>Press v once.</b>		
DHW ON GOOD IGNIT	0H 1X	The top line indicates the hours the burner has been on for hot water demand over the boiler's life. The second line indicates how many times the burner has successfully ignited over the boiler's life.
<b>Press v once.</b>		
SYS CH ON SYS DHW ON	0H 0H	This screen displays how many hours the boiler has run to meet central heat and DHW demand.

**Table 21 - Boiler Control Status Menu Screens**

The next ten screens display the last ten boiler lockout faults. Press **v** to scroll through the faults from most recent to oldest.

Screen	Description
FAULT HISTORY 1 07/27/2009 Mo 5:19A	This screen displays the most recent boiler control lockout fault. The top line will alternate between the words 'FAULT HISTORY' and the fault code encountered. The bottom line displays the date and time the fault occurred.
<b>Press v once.</b>	
FAULT HISTORY 2 08/28/2009 Fr 5:19A	This screen displays the second oldest boiler control lockout fault. The top line will alternate between the words 'FAULT HISTORY' and the actual fault encountered. The bottom line will display the date and time that the fault occurred.
<b>Press v once.</b>	
FAULT HISTORY 3 08/28/2009 Fr 5:19A	This screen displays the third oldest boiler control lockout fault. The top line will alternate between the words 'FAULT HISTORY' and the actual fault encountered. The bottom line will display the date and time that the fault occurred.
<b>Press v once.</b>	

FAULT HISTORY 4 08/28/2009 Fr 5:19A	This screen displays the fourth oldest boiler control lockout fault. The top line will alternate between the words 'FAULT HISTORY' and the actual fault encountered. The bottom line will display the date and time that the fault occurred.
<b>Press v once.</b>	
FAULT HISTORY 5 08/28/2009 Fr 5:19A	This screen displays the fifth oldest boiler control lockout fault. The top line will alternate between the words 'FAULT HISTORY' and the actual fault encountered. The bottom line will display the date and time that the fault occurred.
<b>Press v once.</b>	
FAULT HISTORY 6 08/28/2009 Fr 5:19A	This screen displays the sixth oldest boiler control lockout fault. The top line will alternate between the words 'FAULT HISTORY' and the actual fault encountered. The bottom line will display the date and time that the fault occurred.
<b>Press v once.</b>	
FAULT HISTORY 7 08/28/2009 Fr 5:19A	This screen displays the seventh oldest boiler control lockout fault. The top line will alternate between the words 'FAULT HISTORY' and the actual fault encountered. The bottom line will display the date and time that the fault occurred.
<b>Press v once.</b>	
FAULT HISTORY 8 08/28/2009 Fr 5:19A	This screen displays the eighth oldest boiler control lockout fault. The top line will alternate between the words 'FAULT HISTORY' and the actual fault encountered. The bottom line will display the date and time that the fault occurred.
<b>Press v once.</b>	
FAULT HISTORY 9 08/28/2009 Fr 5:19A	This screen displays the ninth oldest boiler control lockout fault. The top line will alternate between the words 'FAULT HISTORY' and the actual fault encountered. The bottom line will display the date and time that the fault occurred.
<b>Press v once.</b>	
FAULT HISTORY 10 08/28/2009 Fr 5:19A	This screen displays the tenth oldest boiler control lockout fault. The top line will alternate between the words 'FAULT HISTORY' and the actual fault encountered. The bottom line will display the date and time that the fault occurred.

**Table 22 - Boiler Fault Screens**

**B. Cascade Menu**

This menu is accessed by pressing < at the default menu or > at the status menu.

Screen	Description
CASCADE MASTER READY SYS PUMP OFF	This screen displays when the boiler is configured as a Cascade Master and the system is ready to accept a demand for heat. The second line indicates the cascade system pump output status. This screen alternates with the default screen every 5 seconds or can be accessed by pressing the < key from the default screen.
CASCADE NO FOLLOWER SYS PUMP OFF	This screen displays when the boiler is configured as a Master Boiler and there are no connected follower boilers, or the follower boilers are not powered. The second line indicates cascade system pump output status. This screen alternates with the default screen every 5 seconds or can be accessed by pressing the < key from the default screen.
CASCADE NO SENSOR SYS PUMP OFF	This screen displays when the boiler is configured as a Master Boiler and there is no system temperature sensor connected or the system sensor is defective. The cascade system will still function in this situation with reduced efficiency. All boilers will run simultaneously rather than in a staged fashion. The second line indicates cascade system pump output status. This screen will alternate with the default screen every 5 seconds or can be accessed by pressing the < key from the default screen.
CASCADE TT 0123 567 SYS PUMP ON 12:47P	This screen displays information about cascade status. The TT in the center of the top line shows that cascade demand is coming from the TT contact being closed. You may also see DHW if the demand is from a DHW sensor, or 0-10 if the demand is from a 0-10 volt input. The following numbers show which boiler addresses are currently communicating to the master. If a boiler address is not used or communicating, the number will not display. In the example to the left, boiler address #4 is not communicating. When a boiler in the system is firing, its address number will alternate with a '.' to signify it is firing. The bottom line shows the status of the system pump output contacts.
Press v once.	

CASCADE PWR 100% PRESENT 01234567	This screen displays overall cascade power output. The range of this value is the number of boilers communicating with the Master x 100. For example, if 8 boilers are connected and firing, the maximum cascade power is 800%. The second line shows which boiler addresses are communicating with the Master.
Press v once.	
CASCADE SYST 118°F CASCADE SET 190°F	This screen displays current system temperature sensor reading on the top line and the cascade system temperature setting on the bottom.
Press v once.	
BOILER 0 100% BOILER 1 56%	This screen displays the current cascade power demand output on a per connected boiler basis for boilers addressed as 0 and 1. In the example, boiler 0 is being commanded to fire at 100% and boiler 1 at 56%. If this were a 2 boiler system, the 'CASCADE PWR' screen above would read 156%.
Press v once.	
BOILER 2 0% BOILER 3 0%	This screen displays the current cascade power demand output on a per connected boiler basis for boilers addressed as 2 and 3.
Press v once.	
BOILER 4 0% BOILER 5 0%	This screen displays the current cascade power demand output on a per connected boiler basis for boilers addressed as 4 and 5.
Press v once.	
BOILER 6 0% BOILER 7 0%	This screen displays the current cascade power demand output on a per connected boiler basis for boilers addressed as 6 and 7.

Table 23 - Cascade Menu

**C. Boiler Test Mode**

This function is intended to simplify gas adjustment. The following tables include recommended combustion settings by fuel type and boiler fan speeds. Automatic modulation does not take place while the controller is in Test Mode. However, the boilers will modulate down if the program set point is reached while running in Test Mode. It is recommended to enter Test Mode with the largest load possible to create such a heat demand that Test Mode will not be interrupted. To enter Test Mode press ^ and ENTER simultaneously.

**NOTE:** The boiler will automatically exit Test Mode after 20 minutes of operation.

To leave Test Mode press ^ and v simultaneously.

SERVICE RUN	3400 RPM
PUMP ON	4:49P

Combustion Settings on All Models						
Fan Speed	Natural Gas (NG)			Propane (LP)		
	Low	Ignition	High	Low	Ignition	High
Carbon Monoxide (CO) PPM	5-50	60-100	≤150	5-50	60-100	≤150
Carbon Dioxide (CO <sub>2</sub> ) %	8-10	8 1/2-10 1/2		9-10 1/2	9 1/2-11	

Table 24 - Combustion Settings - All Models

Fan Speeds			
BTU	Ignition	Min	Max
55,000	3800	1650	4050
80,000		1850	5000
110,000			6050
155,000	4100	1750	5400
199,000	3800		6050
285,000	4600		
399,000	4200	1900	6950

Table 25 - Fan Speeds

## Part 11 - Troubleshooting

### A. Boiler Error and Fault Codes

If any of the sensors detect an abnormal condition, or an internal component fails during the operation of the boiler, the display may show an error message and error code. This message and code may be the result of a temporary condition, in which case the display will revert to its normal readout when the condition is corrected, or it may be a condition that the controller has evaluated as not safe to restart the boiler. In this case, the boiler control will be locked out, the red FAULT light will be lit, and the message "LOCKOUT" will be displayed on the readout in the lower line.

The boiler will not start until a qualified technician has repaired the boiler and pressed the RESET button for more than 1 second. If there is an error message displayed on the readout, and the message "LOCKOUT" is not displayed and the FAULT light is not lit, then the message is the result of a temporary condition and will disappear when the problem corrects itself.

**IMPORTANT NOTE:** If you see error messages on your display readout, call a technician immediately, since the message may indicate a more serious problem will occur soon.



### B. Boiler Error

The controller will display an error code and message when an error condition occurs. These error codes, descriptions, and recommended corrective actions are described in Section D.

### C. Boiler Fault

1. The controller will illuminate the red "FAULT" indication light and display a fault code and message when a fault condition occurs. The alarm output will also activate. Most fault conditions cause the CH pump to run in an attempt to cool the boiler.
2. Note the displayed fault code and refer to Section D for an explanation of the message along with several suggestions for corrective actions.
3. Press **RESET** to clear the fault and resume operation. Be sure to observe the operation of the unit for a period of time to assure

correct operation and no reoccurrence of fault message.

 <b>WARNING</b>
<p>When servicing or replacing components that are in direct contact with boiler water, be certain that:</p> <ul style="list-style-type: none"> <li>• There is no pressure in the boiler. (Pull the release on the relief valve. Do not depend on the pressure gauge reading.</li> <li>• The boiler water is not hot.</li> <li>• The electrical power is disconnected.</li> <li>• The gas is shut off.</li> </ul> <p>Failure to make these checks could result in substantial property damage, serious personal injury, or death.</p> <p><b>DO NOT USE THIS APPLIANCE IF ANY PART HAS BEEN SUBMERGED IN WATER.</b> Immediately call a qualified service technician. The appliance <b>MUST BE</b> replaced if it has been submerged. Attempting to operate an appliance that has been submerged could create numerous harmful conditions, such as a potential gas leakage causing a fire and/or explosion, or the release of mold, bacteria, or other harmful particulates into the air. Operating a previously submerged appliance could result in property damage, severe personal injury, or death.</p> <p><b>NOTE:</b> Appliance damage due to flood or submersion is considered an Act of God, and IS NOT covered under product warranty.</p> <p>If overheating occurs or the gas supply fails to shut off, do not turn off electrical power to the circulating pump. This may aggravate the problem and increase the likelihood of boiler damage. Instead, shut off the gas supply to the boiler at the gas service valve. Failure to do so may result in property damage, personal injury, or death.</p>
 <b>CAUTION</b>
<p>Label all wires prior to disconnecting them when servicing the boiler. Wiring errors can cause improper and dangerous operation. Failure to follow these instructions may result in property damage or personal injury.</p> <p><b>NOTE:</b> If system return temperatures are maintained below the dew point, condensation will form on the inside of the boiler cabinet and cause some internal sheet metal components to rust.</p>



## D. User Interface Display

### Cascade Control Fault Codes

Screen	Description	Possible Remedy
SYS SUPPLY SENSOR PUMP OFF E03	E03 indicates a problem with the system sensor circuit. The circuit could be open or shorted. Possible reasons for this error are: There is no system sensor connected to the Master Boiler. The system sensor is faulty. There is a short circuit in the system sensor wiring; possibly from a staple placed through the wire, or damage to the wire causing both conductors to touch. The system sensor wiring is open due to defect or damage.	Disconnect the system sensor from the wiring and measure it's resistance. Compare the measured resistance to the table in this manual to see if it corresponds to the temperature of the sensor. If the resistance does not agree with the sensor, replace the sensor. If the sensor is OK, disconnect the sensor wiring from both the boiler and the sensor and check continuity using an ohmmeter. Repair or replace as necessary. If this error is present, the boilers in the cascaded group will run and ignite simultaneously when there is a heat demand. Each boiler will modulate to maintain set point temperature on its own supply sensor. This code automatically resets when repair is complete. This code will not display if system setting function ERROR SYSTEM SENS is set to OFF.
TEMPER BLOCKING PUMP ON TT	TT indicates there is a demand for heat on the boiler, the pump is powered on, and the supply sensor temperature is too high for the boiler to ignite. This occurs because the water temperature measured by the supply sensor is higher than the boiler temperature – ignition diff setting.	This message will stay present until the water temperature measured by the supply sensor is less than the boiler temperature – ignition diff setting.
TEMPER BLOCKING PUMP ON DHW	This display indicates a temporary hold on the burner. There is a demand on the boiler from the DHW circuit for heat, the pump is powered on, but the boiler supply sensor indicates that the water temperature is too high to ignite. This is a temporary hold on the burner only and all other functions will remain functioning properly.	This error will clear itself when either the boiler supply temperature drops below the BOILER SUPPLY minus boiler supply differential (5°F) or DHW SETPOINT is satisfied and no longer calls for heat.
LOW WATER PRESS PUMP OFF PRO	PRO indicates low water pressure in the boiler. This code will reset automatically after the water pressure is high enough for the boiler to run safely. The second line indicates the status of the pump. Note that while the water pressure is low, the pump will be off.	<ol style="list-style-type: none"> <li>1. Assure that the system pressure is above 10 psig.</li> <li>2. Check for leaks in the system piping.</li> </ol>
HIGH FLUE PRESS FLU PUMP ON	FLU indicates excessive flue pressure. This code resets automatically after the high pressure condition is resolved. The second line indicates pump status.	<ol style="list-style-type: none"> <li>1. Assure the flue is not blocked.</li> <li>2. Check the switch wiring by applying a jumper in place of the switch. If the code clears with the jumper in place, REPLACE the flue switch and connect the wires to the new switch BEFORE running boiler.</li> </ol>
<b>WARNING:</b> Do not use jumper to remedy an FLU error. Faulty switch MUST be replaced. Failure to follow this instruction could result in serious personal injury or death.		

<p>24 VOLT LOW LOU PUMP ON</p>	<p>LOU indicates the 24 volt power supply on the control is damaged or overloaded. This code resets automatically if it is the result of an overload and the overload condition is removed. The second line indicates the status of the pump. Note that while 24 volt power is low, the pump output will be on.</p>	<ol style="list-style-type: none"> <li>1. Check line voltage. It must be between 100 and 128 volts.</li> <li>2. If available, connect a PC and use HTP service software to check the 24v supply display in the lower left corner of the screen. The number displayed here must be greater than 128 and should be no greater than 250. Use this as a troubleshooting guide as you follow the steps below.</li> <li>3. Remove the 10 pin Molex connector from the customer connection board. If the message clears the problem is with external sensor wiring. Examine the external sensor wiring for shorts to the ground, repairing as necessary. If the message is still present and the boiler is so equipped, disconnect the UL 353 low water cut-off to see if the message clears. Replace the faulty part. Check the low voltage wire harness in boiler for shorts to ground.</li> <li>4. If a message only occurs when the burner tries to light, check the gas valve for excessive current draw.</li> <li>5. If a message is present when the low voltage harness is disconnected from the 926 control board, replace the 926 control board.</li> </ol>
<p>WATER HIGH TEMP Foo PUMP ON</p>	<p>Foo indicates the water in the boiler has overheated. The boiler will not restart until it cools sufficiently and a technician determines and repairs the cause of overheating and pushes <b>RESET</b> on the display. This is a serious safety issue as indicated by the illuminated red light and the word LOCKOUT flashing on the display. During this lockout fault, the pump will be on in an effort to cool the boiler down.</p>	<ol style="list-style-type: none"> <li>1. Check circulator pump operation.</li> <li>2. If the circulator pump is running, ensure there is water in the system and that the water is moving through the system as intended. Ensure that all correct ball valves and or zone valves are open or closed as intended.</li> <li>3. Observe the temperature/pressure gauge. If the water is not too hot and this message is displayed, check the wiring to the water ECO sensor and repair if necessary. If the wiring is ok and this code is still present and the water is not excessively hot, replace the ECO sensor.</li> </ol>
<p>FLUE TEMP/WAT LV Fo1 PUMP ON</p>	<p>Fo1 indicates that the flue temperature limit switch of the boiler has tripped or that the water level in the boiler is low (this will only occur if the optional UL353 LWCO is installed). This code indicates a serious safety issue. The boiler will not restart until the flue cools down sufficiently or the water level is restored. A technician must repair the cause of the problem and push the RESET button first on the low water cut-off control box, then on the display. This situation is indicated by the red light on the display and the word LOCKOUT flashing on the display. During this lockout fault, the pump will be on as indicated on the second line of the display.</p>	<ol style="list-style-type: none"> <li>1. If the boiler has a UL353 LWCO, check if the red LED on the LWCO control box is illuminated. If so, correct the low water condition and press the reset button on the LWCO control box to reset the LWCO. The LED should change to green. Press the reset button on the front panel of the boiler to reset the boiler control.</li> <li>2. Check the flue for obstructions or any sign of damage, especially signs of excessive heat. Repair as necessary. Push the red reset button on the flue temperature switch located on the flue inside the rear access door of the boiler. NOTE: The switch temperature must be less than 90°F to reset. Press the reset button on the display. Run the boiler and check the flue temperature by using both an external thermometer in the flue pipe and the flue temperature display in the status screens. If the flue temperature is within specs and the switch trips, replace the switch. If the flue temperature is excessive, check and adjust combustion controls on the boiler. If the problem persists, inspect the target wall in the combustion chamber and replace it if cracked or damaged.</li> </ol>
<p>SUPPLY SENSOR Fo2 PUMP ON</p>	<p>Fo2 indicates the supply temperature sensor of the boiler has failed. The boiler will not restart until a technician replaces the sensor and pushes <b>RESET</b> on the display. This is a serious safety issue as indicated by the illuminated red light and the word LOCKOUT flashing on the display. During this lockout fault, the pump will be on.</p>	<ol style="list-style-type: none"> <li>1. Check the electrical connection to the thermistor on the outlet manifold. Verify 5 VDC by checking the Molex connector. If there is no 5 VDC, check the harness. If harness is OK, replace the control. Verify thermistor values by referencing chart in this manual.</li> <li>2. Replace thermistor if necessary. <b>NOTE:</b> The boiler will reset automatically once the fault is corrected.</li> </ol>

RETURN SENSOR F03 PUMP ON	F03 indicates the return temperature sensor of the boiler has failed. The boiler will not restart until a technician replaces the sensor and pushes <b>RESET</b> on the display. This is a serious safety issue as indicated by the illuminated red light and the word LOCKOUT flashing on the display. During this lockout fault, the pump will be on.	<ol style="list-style-type: none"> <li>1. Check circulator pump operation.</li> <li>2. Ensure adequate flow through the boiler by accessing the status menu and determining there is less than a 50°F rise from the return thermistor to the supply thermistor.</li> <li>3. Troubleshoot thermistor by following the steps in F02.</li> </ol>
FLUE SENSOR F04 PUMP ON	F04 indicates that the flue temperature sensor of the boiler has failed. The boiler will not restart until a technician replaces the sensor and pushes <b>RESET</b> on the display. This is a serious safety issue as indicated by the illuminated red light and the word LOCKOUT flashing on the display. During this lockout fault, the pump will be on.	Inspect the flue sensor for physical damage or corrosion and replace it if necessary. Check the electrical connection to the flue sensor and repair as necessary. Measure the resistance of the sensor and refer to the sensor resistance table in this manual. The temperature on the chart should be close to the temperature in the flue. If not, replace the flue sensor.
SUPPLY TEMP HIGH F05 PUMP ON	F05 indicates the boiler supply temperature is excessive. When accompanied by the red FAULT light and LOCKOUT flashing on the display, this code indicates the supply sensor temperature has exceeded 199°F and a serious safety issue exists. The boiler will not restart until a technician determines and repairs the cause of excessive temperature and pushes <b>RESET</b> on the display. If the FAULT light is not illuminated and this message is displayed, the supply temperature of the boiler is at or above 199°F. The message will clear automatically when the temperature drops below 194°F. During the time that this fault is displayed, the pump will be on.	<ol style="list-style-type: none"> <li>1. Check circulator pump operation.</li> <li>2. Ensure adequate flow through the boiler by accessing the status menu and determining there is less than a 50°F rise from the return thermistor to the supply thermistor.</li> <li>3. Check the direction of flow off the boiler circulator. (See Applications in this manual.)</li> <li>4. Troubleshoot the thermistor by following steps in F02.</li> </ol>
RETURN TEMP HIGH F06 PUMP ON	This display indicates that the boiler return temperature is excessive. When accompanied by the red FAULT light and LOCKOUT flashing on the display, this code indicates that the return sensor temperature has exceeded 199°F and a serious safety issue exists. The boiler will not restart until a technician determines and repairs the cause of excessive temperature and pushes <b>RESET</b> on the display. If the red FAULT light is not illuminated and this message is displayed, then the return temperature of the boiler is at or above 199°F. The message will clear automatically when the temperature drops below 194°F. During the time that this message or lockout fault is displayed, the pump will be on.	<ol style="list-style-type: none"> <li>1. Check circulator pump operation.</li> <li>2. Ensure adequate flow through the boiler by accessing the status menu and determining there is less than a 50°F rise from the return thermistor to the supply thermistor.</li> <li>3. Check the direction of flow on boiler circulator. (See Applications in this manual.)</li> <li>4. Troubleshoot thermistor by following steps in F02.</li> </ol>

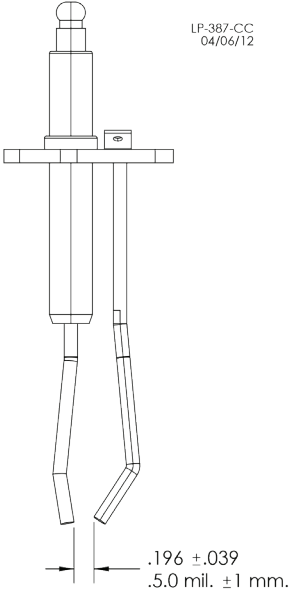
<p>NO FLAME ON IGN F09 PUMP ON</p>	<p>The boiler tried to ignite four times during one heat call and failed. This is a serious safety issue as indicated by the illuminated red light and the word LOCKOUT flashing on the display. The boiler will not restart until a technician determines and repairs the cause of ignition failure and pushes <b>RESET</b> on the display. During this lockout fault, the pump will remain on.</p>	<ol style="list-style-type: none"> <li>1. Watch the igniter through the observation window.</li> <li>2. If there is no spark, check the spark electrode for the proper .156" (3.96 mm) gap. See below.</li> <li>3. Remove any corrosion from the spark electrode and flame rectifier probe.</li> <li>4. If there is a spark but no flame, check the gas supply to the boiler.</li> <li>5. If there is a flame, check the flame sensor.</li> <li>6. Check any flue blockage or condensate blocks.</li> </ol> 
<p>FLAME LOSS F10 PUMP ON</p>	<p>The flame was lost 3 times while the boiler was firing during 1 demand call. This is a serious safety issue as indicated by the illuminated red light and the word LOCKOUT flashing on the display. The boiler will not restart until a technician determines and repairs the cause of flame loss and pushes <b>RESET</b> on the display. During this lockout fault, the pump will be on.</p>	<ol style="list-style-type: none"> <li>1. Monitor gas pressure to the unit while in operation.</li> <li>2. Assure the flame is stable when lit.</li> <li>3. Check if the display readout changes from "GAS VALVE ON" to "RUN" within a few seconds of boiler ignites.</li> <li>4. Check the FLAME signal on the display. It should be above 1.0 when the boiler is firing.</li> <li>5. If the signal reads less than 1 microampere, clean the flame rectifier and spark probe.</li> <li>6. If the problem persists and the 'FLAME' signal is still less than 1.0, replace the flame probe and spark igniter probe.</li> <li>7. The flame signal should be steady after the boiler has been firing for 1 minute and is normally at 5.0 to 9.0. If the flame signal is not steady, disassemble the burner door and check the burner and its sealing gaskets.</li> </ol>
<p>FALSE FLAME SIG F11 PUMP ON</p>	<p>There is flame when the control is not telling the boiler to run. This is a serious safety issue as indicated by the illuminated red light and the word LOCKOUT flashing on the display. The boiler will not restart until a technician determines and repairs the cause and pushes <b>RESET</b> on the display. During this lockout fault, the pump will be on.</p>	<ol style="list-style-type: none"> <li>1. Look into window. If there is flame, turn the gas off to the unit at the service valve and replace the gas valve.</li> <li>2. If the flame signal on the status menu is greater than 1.0 when the burner is not lit, replace the spark ignitor and the flame rectification probe.</li> <li>3. If the flame signal is not present after turning off the gas supply, check the gas valve electrical connection.</li> <li>4. Check for condensate backup. Repair condensate system as necessary. If condensate has partially filled the combustion chamber, the refractory wall may be damaged and should be replaced.</li> <li>5. Turn the gas on at the service valve after corrective action is taken.</li> <li>6. If the refractory wall falls against the rectifier probe, it may conduct the signal to ground, giving a false reading.</li> </ol>

FAN SPEED ERROR F13 PUMP ON	The fan is not running at the speed determined by the control. Fan speed has been more than 30% faster or slower than the commanded speed for more than 10 seconds. This is a serious safety issue as indicated by the illuminated red light and the word LOCKOUT flashing on the display. This boiler will not restart until a technician determines and repairs the cause and pushes <b>RESET</b> on the display. During this lockout fault, the pump will be on.	<ol style="list-style-type: none"> <li>1. Check the combustion fan wiring.</li> <li>2. Measure DC voltage from the red fan wire to ground while it is connected to the fan. It should be between 24 and 40 volts. If it is lower than 24 volts, check for excessive external loads connected to the boiler sensor terminals</li> <li>3. Disconnect the 5 pin plug from the fan and check the voltage on the red wire again. If it is now between 24-40 volts, replace the fan. If it is still below 24 volts replace the boiler control board.</li> </ol>
CONDENSATE FULL F20 PUMP OFF	The condensate trap is full. This is a serious safety issue as indicated by the illuminated red light and the word LOCKOUT flashing on the display. The boiler will not restart until a technician determines and repairs the cause and pushes <b>RESET</b> on the display. During this lockout fault, the pump will be off.	<ol style="list-style-type: none"> <li>1. Check condensate lines for obstructions.</li> <li>2. Check float switch in condensate reservoir.</li> <li>3. Check wiring from condensate reservoir to g26 control and repair as necessary.</li> </ol>
PROGRAM ERROR F31 PUMP OFF	There was an error while programming the control and the memory is corrupt. The boiler control will not function in this state and the pump will be off as indicated on the bottom line. This error only occurs if a technician is programming the control and the programming function fails. The only way to recover from this error is to reprogram the control. If this error occurs at any time other than when a technician is servicing the boiler, the control has failed and must be replaced by a qualified technician.	The control must be reprogrammed. If programming does not solve the problem, the control must be replaced.
CONTROL PROGRAMED PP	The control has been programmed by a technician or the factory. After programming, the control is left in a locked out mode.	Press <b>RESET</b> for at least 1 second to use the control.
OUTDOOR SENSOR FOU PUMP ON 1:45P	FOU indicates an issue with the outdoor sensor. It is shorted, damaged, or disconnected from the boiler.	<ol style="list-style-type: none"> <li>1. Check outdoor sensor connections and wiring. Ensure the sensor and wiring are intact and that the sensor is connected to the boiler.</li> <li>2. Check the outdoor sensor resistance with an ohmmeter. See Table 27 for correct outdoor sensor resistance.</li> <li>3. Replace the outdoor sensor.</li> </ol>
<b>NOTE:</b> If an outdoor sensor IS NOT used in the installation, enter the System Setting Program Navigation, go to Function 21, and turn the setting from ON to OFF.		
<b>The following blocking codes will block operation until the control determines the situation safe for boiler operation.</b>		
FLUE TEMP HIGH E07 PUMP OFF TIME	E07 indicates the flue sensor temperature is excessive and above 210°F. When E07 is displayed the boiler will not respond to a demand for heat. When the flue temperature decreases below 194°F, the display will return to normal and allow the boiler to respond to a heat demand. The bottom line indicates the status of the pump. The pump will remain off when this error is displayed.	Check the flue for obstructions and any sign of damage, especially signs of excessive heat. Repair as necessary. Run the boiler and check the flue temperature with an external thermometer. If the flue temperature on the thermometer does not agree with the flue temperature displayed in the status menu, inspect the wiring to the flue temperature sensor in the boiler and repair as necessary. If the wiring is intact replace the flue sensor. If the flue temperature is excessive on the status menu and the test thermometer reads the same, check and adjust combustion controls on the boiler. If the problem persists, inspect the target wall in the combustion chamber and replace it if cracked or damaged.
LINE VOLTAGE E19 PUMP OFF	E19 indicates the line voltage frequency is out of range. This could happen if the boiler is being powered from a small gasoline powered generator that is overloaded or not functioning correctly.	Inspect power wiring to the boiler and repair as necessary. If connected to line voltage, notify the power company. If connected to an alternate power source such as a generator or inverter, make sure the line voltage frequency supplied by the device is 60 Hz.

Table 26 - Boiler Error and Fault Codes

## Part 12 - Maintenance

### A. Procedures

Periodic maintenance should be performed once a year by a qualified service technician to assure that all the equipment is operating safely and efficiently. The owner should make necessary arrangements with a qualified heating contractor for periodic maintenance of the boiler. The installer must also inform the owner that a lack of proper care and maintenance of the boiler may result in a hazardous condition.

### WARNING

BEFORE EACH HEATING SEASON a trained and qualified service technician should perform the inspections as per the boiler inspection and maintenance schedule in this manual. Failure to do so could result in death or serious injury.

The combustion chamber insulation in this product contains ceramic fiber material. Ceramic fibers can be converted to cristobalite in very high temperature applications. The International Agency for Research on Cancer (IARC) has concluded, "Crystalline silica inhaled in the form of quartz or cristobalite from occupational sources is carcinogenic to humans (Group 1)."

- Avoid breathing dust and contact with skin and eyes.
- Use a NIOSH certified dust respirator (N95). This type of respirator is based on the OSHA requirements for cristobalite at the time this document was written. Other types of respirators may be needed depending on job site conditions. Current NIOSH recommendations can be found on the NIOSH website: <http://www.cdc.gov/niosh/homepage.html>. NIOSH approved respirators, manufacturers, and phone numbers are also listed on this website.
- Wear long-sleeved, loose fitting clothing, gloves, and eye protection.
- Apply enough water to the combustion chamber lining to prevent dust.
- Wash potentially contaminated clothes separately from other clothing. Rinse clothes washer thoroughly.

NIOSH stated First Aid.

- Eye: Irrigate immediately.
- Breathing: Fresh air.

### B. Combustion Chamber Coil Cleaning Instructions

\*Before beginning this procedure, have on hand the following items:

- a nylon, stainless steel, or brass brush (not steel)
- an FDA approved liquid lime scale remover in a spray bottle
- gloves and eye protection

1. Shut down the boiler by using the following steps:
  - a. Turn off power to the boiler. Turn thermostats down to ensure there is no call for heat, or disconnect thermostat connections from terminals. Close the gas valve inside the boiler cabinet. Wait for the boiler to be cool to the touch.
  - b. Disconnect the wires plugged into the fan, spark electrode, flame rod, and gas valve.
  - c. Disconnect the flexible gas lines from the venture attached to the fan.
  - d. Loosen the nuts that hold the burner plate to the heat exchanger.

- e. Remove the combustion assembly.
2. Spray water or solution into the combustion assembly and monitor the flow through the combustion system. Liquid should flow freely through each tube. If there is an obstruction, increase the flow on the tube to force blockage out.
3. Once complete, reinstall the combustion assembly with gaskets and secure nuts. Tighten properly.
  - a. Reconnect all wire and piping connections. Once connected, apply power and disconnect the wire harness with the white-blue-red-black wires to run fan and dry combustion assembly. Let fan run for five minutes. When finished, reconnect harness to the fan.
  - b. Connect the thermostat wires to the field connection board, or turn up thermostat to fire the combustion system. Check for leaks in the combustion system. Observe operation for 5 to 10 minutes.

If boiler is operating properly, condensate is flowing normally, and no gas leaks are detected, combustion coil cleaning is complete.

### WARNING

Do not use solvents to clean any of the burner components. The components could be damaged, resulting in unreliable or unsafe boiler operation, substantial property damage, severe personal injury, or death.

Outdoor Sensor (7250P-319)		Supply Temperature Sensor (7250P-324) Boiler Sensor (7250P-667) Indirect Sensor (7350P-325)	
Outside Temperature (°F)	Resistance (ohms)	High / Low Temp Sensor Temp. (°F)	Resistance (Ohms)
-22	171800	32	32550
-13	129800	41	25340
-4	98930	50	19870
5	76020	59	15700
14	58880	68	12490
23	45950	77	10000
32	36130	86	8059
41	28600	95	6535
50	22800	104	5330
59	18300	113	4372
68	14770	122	3605
77	12000	131	2989
86	9804	140	2490
95	8054	149	2084
104	6652	158	1753
113	5522	167	1481
		176	1256
		185	1070
		194	915
		202	786
		212	667

Table 27 - Sensor Temperature Resistance

### C. Cleaning Water Side of Heat Exchanger

1. Make sure power is turned off to the boiler. Run water through the hot water system to ensure it is below room temperature.
2. Close isolation valves on the return and supply connections to the boilers as shown in the piping diagrams in this manual. Slowly open the ball valves and release pressure into a bucket. Once pressure is released, connect a hose to the water line to flush the boiler. Scale removing solution may be used, but must be approved for use with stainless steel and FDA approved for use in a potable water system.
3. Thoroughly flush the heat exchanger before commissioning the unit back in service.

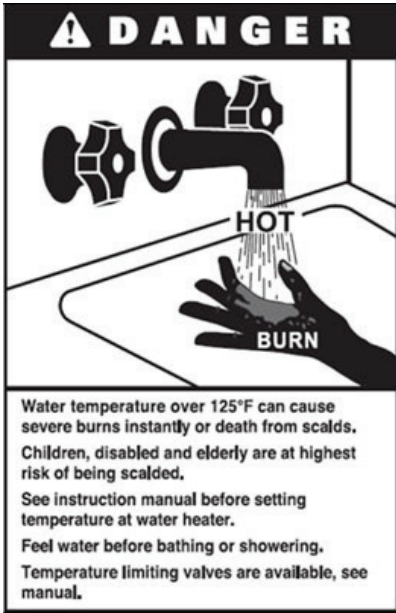

### D. Maintaining the Condensate System

**⚠ DANGER**

The condensate trap assembly **MUST BE PROPERLY INSTALLED** according to these instructions when operating the boiler. Operating the boiler without the condensate trap assembly will cause flue gases to leak and result in serious personal injury or death.

When servicing is complete, make sure the condensate collector cap is replaced securely. Failure to do so will cause venting issues that will result in serious injury or death.

1. Ensure the boiler is powered off and has had time to cool.
2. Remove the stainless steel lock pin to release the condensate trap. Remove the clear plastic hose from the hose barb. Remove the trap from the drain tube.
3. Remove the bottom cap from the condensate trap.
4. Flush trap with fresh water to remove debris from the trap. **NOTE:** Ensure the float moves freely within the trap. If the float does not move, **DO NOT** reinstall the trap.
5. When the condensate trap is sufficiently clean, reinstall the bottom cap on the trap. **NOTE:** Ensure all parts shown in Figure 36, Condensate Detail, are installed with the condensate trap. If any parts are missing, **DO NOT** reinstall the trap. Replace the entire assembly.

**⚠ WARNING**

Do not install the condensate assembly if a component is lost or missing. Replace the entire assembly. Failure to follow this warning could result in property damage, serious personal injury, or death.

6. Fill the condensate trap with fresh water prior to reassembly on the boiler.

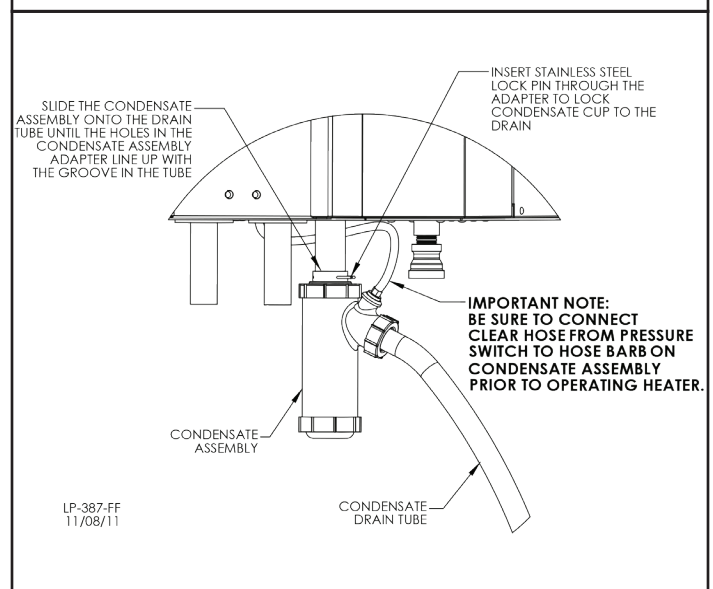
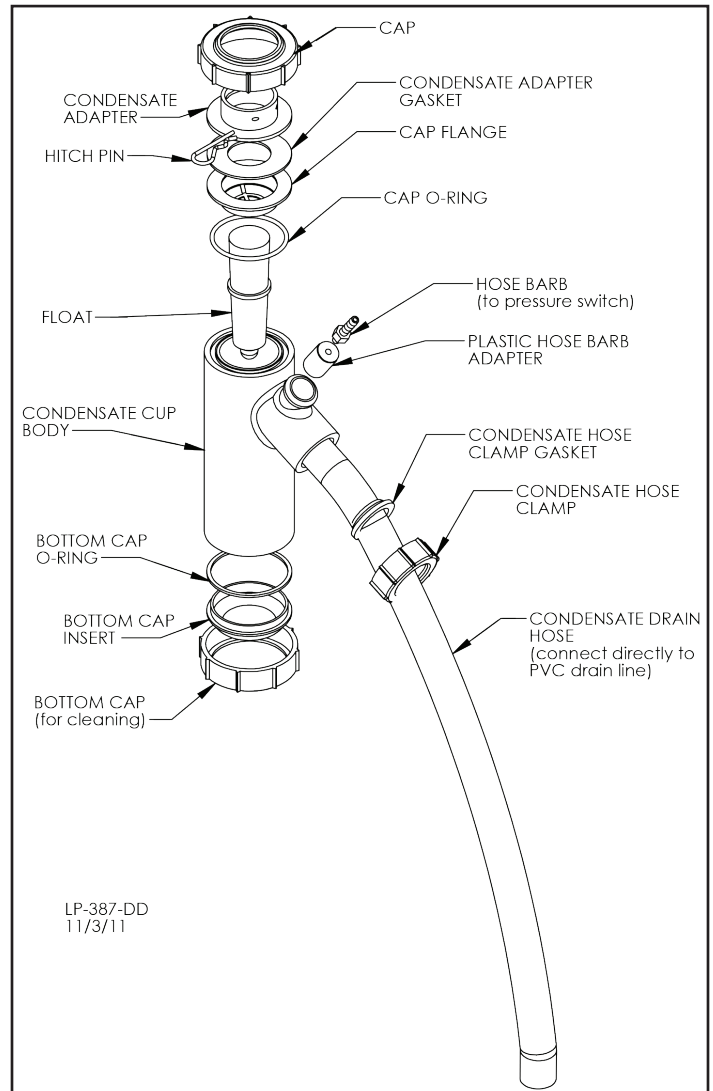

**Figure 36 - Condensate Detail**

7. Slide the condensate trap adapter onto the drain tube until the holes line up with the groove.
8. Insert the stainless steel hitch pin to lock the condensate adapter to the drain tube.
9. Reattach the clear plastic hose to the hose barb.

## **WARNING**

Do not operate the boiler without the clear hose attached from the hose barb to the pressure switch. Failure to follow this warning could result in property damage, serious personal injury, or death.

10. If a condensate neutralizer kit is installed with the boiler, check the assembly when cleaning the condensate trap, and replenish the limestone chips if necessary. When replacing limestone chips, take care to ensure chips are no smaller than ½" to avoid blockage in condensate piping (for piping details, refer to condensate neutralizer installation instruction.)
11. Check condensate piping for sagging and/or leakage. Repair any sags or leaks before restoring power to the boiler.

## **CAUTION**

It is very important that the condensate piping be no smaller than ½". To prevent sagging and maintain pitch, condensate piping should be supported with pipe supports, and pitched ¼" per foot to allow for proper drainage. Failure to maintain proper pipe size and pitch could result in condensate leakage and potential water damage to property.

The condensate line must remain unobstructed, allowing free flow of condensate. If condensate freezes in the line, or if line is obstructed in any other manner, condensate can exit from the tee, resulting in potential water damage to property.

11. If the boiler has a condensate pump, ensure the pump operates properly before considering maintenance complete.

## **Part 13 - Shutdown**

### **A. Shutdown Procedure**

If the burner is not operating, disconnect the electrical supply. If the burner is operating, lower the set point value to 70°F and wait for the burner to shut off. Continue to wait for the combustion blower to stop, so all latent combustion gases are purged from the system. This should take a maximum of 40 to 90 seconds.

### **B. Vacation Procedure**

If there is danger of freezing, change the set point to 70°F. DO NOT turn off electrical power. If there is no danger of freezing, follow "Shutdown Procedure".

### **C. Failure to Operate**

Should the burner fail to light, the control will perform two more ignition trials prior to entering a lockout state. Note that each subsequent ignition trial will not occur immediately. After a failed ignition trial, the blower must run for approximately 10 seconds to purge the system. Therefore, a time period of approximately 40 to 90 seconds will expire between each ignition trial.

If the burner lights during any one of these three ignition trials, normal operation will resume. If the burner lights, but goes off in about 4 seconds, check the polarity of the wiring. See electrical connection section.

If the burner does not light after the third ignition trial, the control will enter a lockout state. This lockout state indicates that a problem exists with the boiler, the controls, or the gas supply. Under such circumstances, a qualified service technician should be contacted immediately to properly service the boiler and correct the problem. If a technician is not available,

depressing and holding the RESET button for more than 1 second will remove the lockout state so additional trials for ignition can be performed. The unit will try to re-light once every 6 minutes.



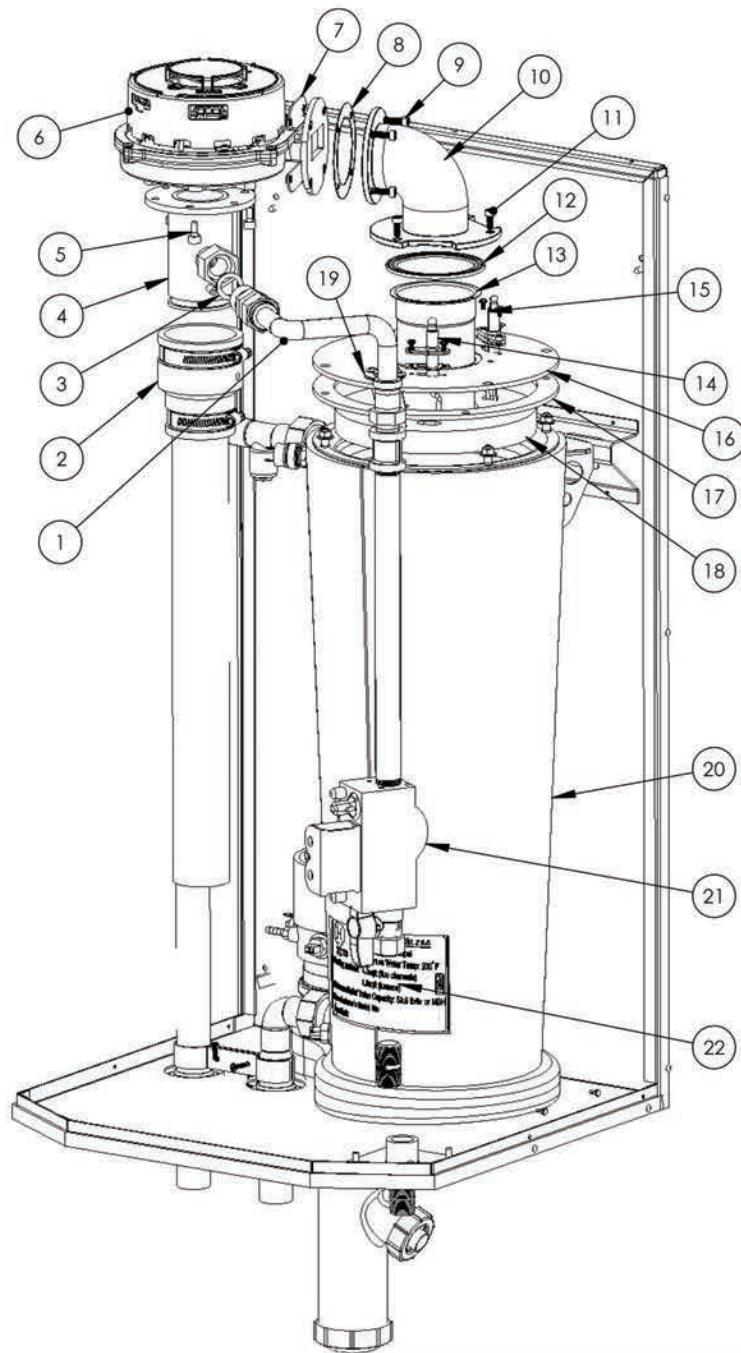

LP-387-J  
06/06/14

ITEM#	REPLACEMENT PART #	DESCRIPTION	ITEM#	REPLACEMENT PART #	DESCRIPTION
1	7100P-140	FLEXIBLE GAS LINE (w/WASHER)		7600P-010	BURNER (w/GASKET) EFT-55, 80
2	7600P-102	AIR INLET ASSEMBLY	14	7600P-087	FLAME RECIFICATION PROBE (w/GASKET, SCREWS)
3	7450P-115	FIBER WASHER - FLEXIBLE GAS LINE	15	7350P-021	IGNITOR (w/GASKET, SCREWS)
4	7450P-022	GAS VENTURI (w/FIBER WASHER)	16	7600P-077	BURNER DOOR
5	7450P-141	M6 X 12MM SCREWS - VENTURI	17	7600P-071	GASKET - BURNER DOOR
6	7500P-195	COMBUSTION BLOWER (w/GASKET)	18	7600P-070	REFRACTORY - BURNER DOOR
7	7600P-041	PLATE - COMBUSTION BLOWER M5	19	7600P-072	SIGHT GLASS (w/GASKET, SCREWS)
8	7500P-075	GASKET - BLOWER TO AIR CHANNEL	20	7600P-002	HEAT EXCHANGER (EFT-55)
9	7250P-477	SCREWS - AIR CHANNEL TO BLOWER		7600P-003	HEAT EXCHANGER ONLY (EFT-80)
10	7600P-001	AIR CHANNEL (w/SCREWS)		7600P-004	HEAT EXCHANGER ONLY (EFT-110)
11	7250P-478	SCREWS - AIR CHANNEL TO HEAT EXCHANGER	21	7450P-025	GAS VALVE
12	7500P-074	GASKET - BURNER	22	7250P-140	GAS SHUT-OFF VALVE
13	7600P-009	BURNER (w/GASKET) EFT-110			

Figure 37 - Combustion System Replacement Parts - 55 - 110kBTU Models

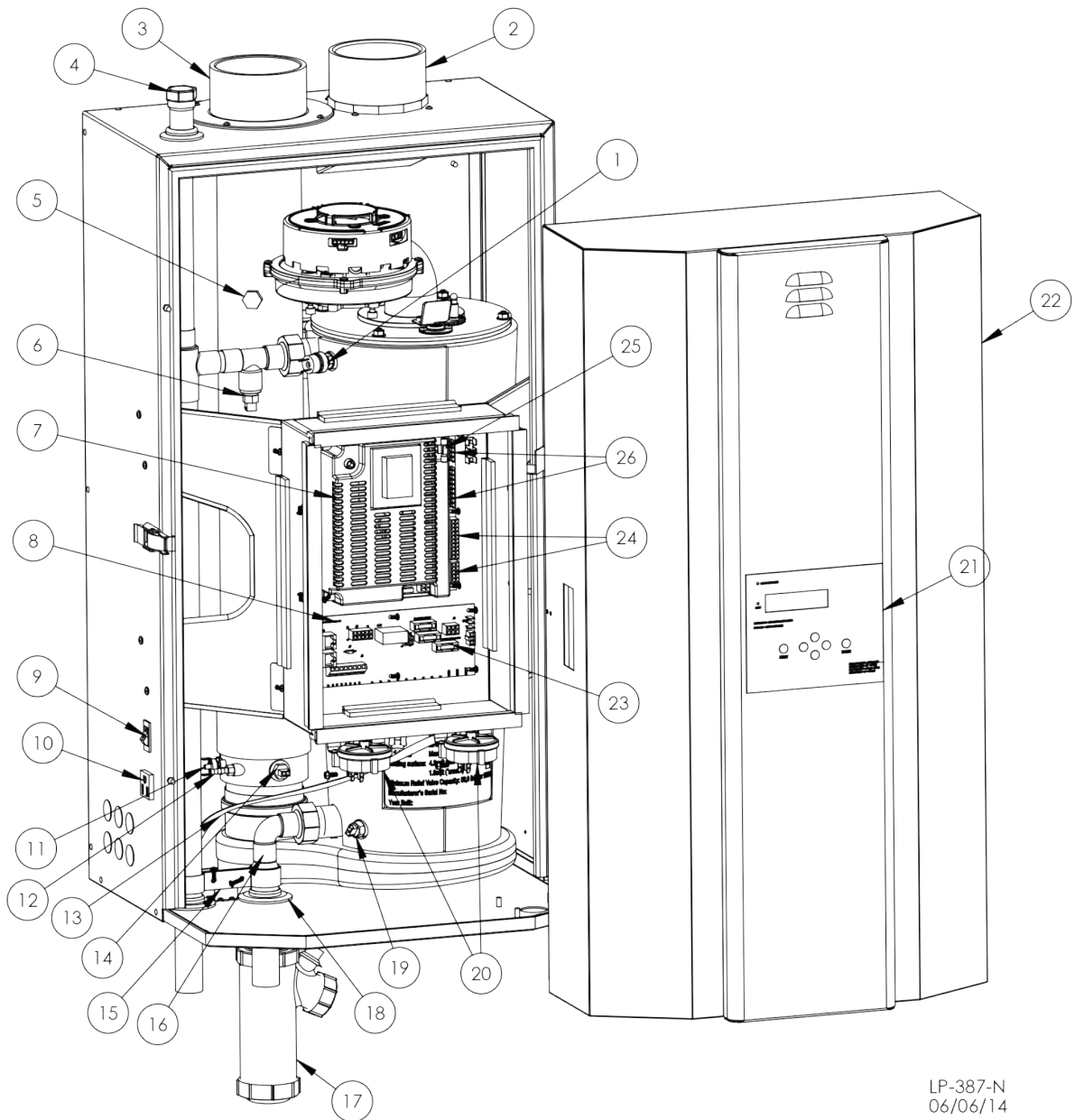

LP-387-N  
06/06/14

ITEM #	REPLACEMENT PART #	DESCRIPTION
1	7600P-007	WATER PRESSURE SWITCH
2	7450P-030	3" PVC INTAKE ADAPTER
3	7600P-060	3" PVC EXHAUST ASSEMBLY
4	7600P-501	SUPPLY PIPING ASSEMBLY
5	7600P-043	PVC PLUG - 1/4"
6	7600P-045	COMBINATION SUPPLY/ HIGH TEMPERATURE SWITCH
7	7450P-122	926 CONTROL BOARD (w/RIBBON CABLE)
8	7350P-070	FIELD CONNECTION BOARD
9	7500P-087	POWER SWITCH
10	7500P-037	CONDENSATE OUTLET
11	7250P-739	FLUE SWITCH
12	7250P-154	S.S. HOSE BARB (w/O-RING)
13	7000P-805	PLASTIC TUBING - PRESSURE SWITCHES
14	7450P-026	FLUE TEMPERATURE SENSOR

ITEM#	REPLACEMENT PART#	DESCRIPTION
15	7600P-036	PIPING BRACKET
16	7600P-500	RETURN PIPING ASSEMBLY
17	7600P-006	CONDENSATE ASSEMBLY
18	7600P-057	PIPE GROMMET
19	7250P-059	THERMISTOR (w/O-RING)
20	7600P-502	PRESSURE SWITCH (w/SCREWS)
21	7600P-005	DISPLAY ASSEMBLY
22	7600P-028	FRONT COVER ASSEMBLY
23	7350P-129	FUSE - 3.15A - CUSTOMER CONNECTION BOARD
24	7600P-101	LOW VOLTAGE WIRING HARNESS (location shown)
25	7250P-378	FUSE - 6.3A - CONTROL BOARD
26	7600P-100	120V WIRING HARNESS (location shown)
27	7250P-653	IGNITOR LEAD CABLE (NOT SHOWN)
28	7250P-080	PRESSURE RELIEF VALVE (NOT SHOWN)

Figure 38 - Replacement Parts - 55 - 110kBTU Models - \*#20 - Switch on the Left is the Blocked Flue Pressure Switch on the Right is the Blocked Condensate Pressure Switch - Both share same Part Number

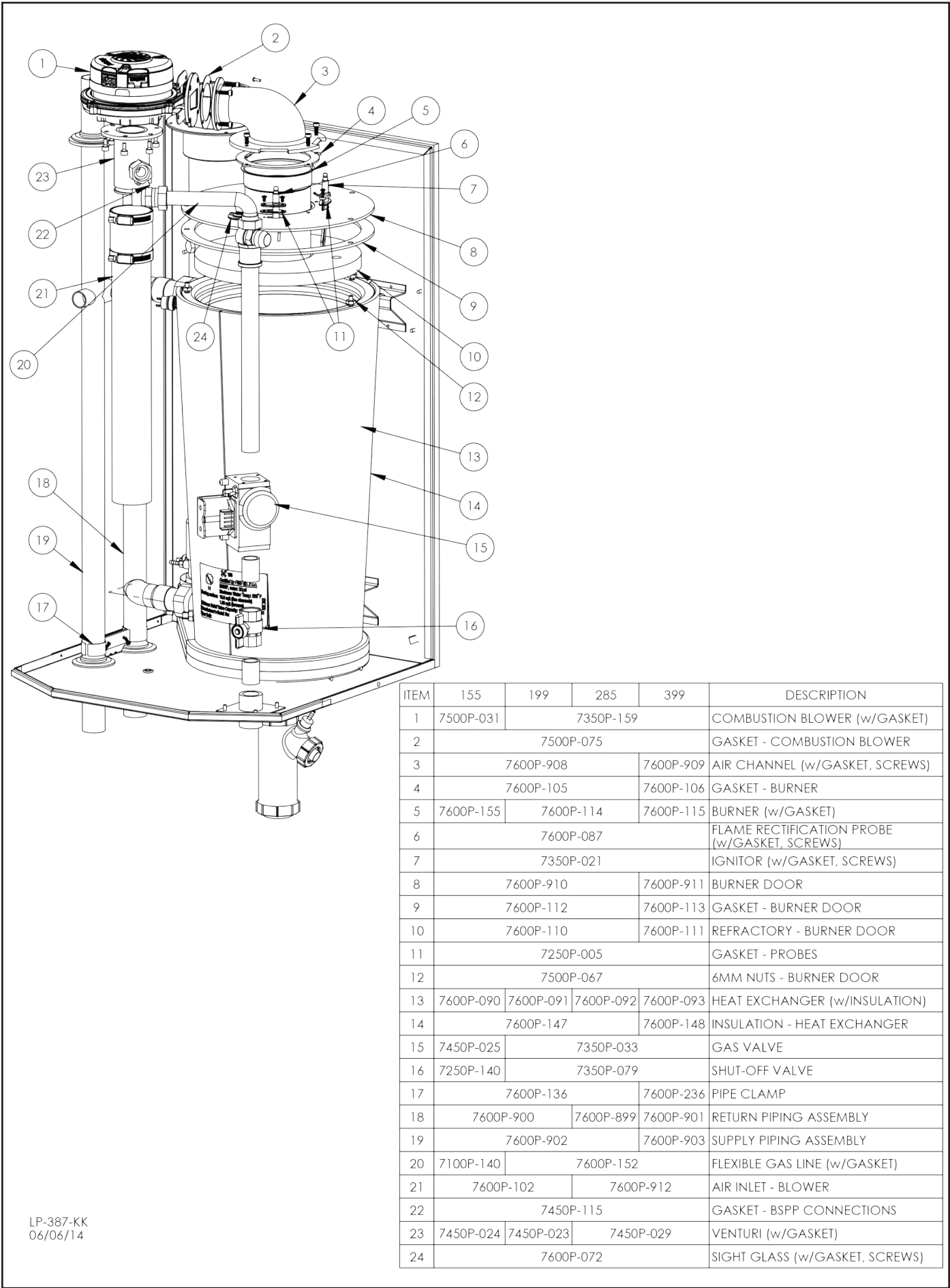

ITEM	155	199	285	399	DESCRIPTION
1	7500P-031	7350P-159			COMBUSTION BLOWER (w/GASKET)
2	7500P-075				GASKET - COMBUSTION BLOWER
3	7600P-908		7600P-909		AIR CHANNEL (w/GASKET, SCREWS)
4	7600P-105		7600P-106		GASKET - BURNER
5	7600P-155	7600P-114		7600P-115	BURNER (w/GASKET)
6	7600P-087				FLAME RECTIFICATION PROBE (w/GASKET, SCREWS)
7	7350P-021				IGNITOR (w/GASKET, SCREWS)
8	7600P-910		7600P-911		BURNER DOOR
9	7600P-112		7600P-113		GASKET - BURNER DOOR
10	7600P-110		7600P-111		REFRACTORY - BURNER DOOR
11	7250P-005				GASKET - PROBES
12	7500P-067				6MM NUTS - BURNER DOOR
13	7600P-090	7600P-091	7600P-092	7600P-093	HEAT EXCHANGER (w/INSULATION)
14	7600P-147			7600P-148	INSULATION - HEAT EXCHANGER
15	7450P-025	7350P-033			GAS VALVE
16	7250P-140	7350P-079			SHUT-OFF VALVE
17	7600P-136			7600P-236	PIPE CLAMP
18	7600P-900		7600P-899	7600P-901	RETURN PIPING ASSEMBLY
19	7600P-902			7600P-903	SUPPLY PIPING ASSEMBLY
20	7100P-140	7600P-152			FLEXIBLE GAS LINE (w/GASKET)
21	7600P-102		7600P-912		AIR INLET - BLOWER
22	7450P-115				GASKET - BSPP CONNECTIONS
23	7450P-024	7450P-023	7450P-029		VENTURI (w/GASKET)
24	7600P-072				SIGHT GLASS (w/GASKET, SCREWS)

LP-387-KK  
06/06/14

Figure 39 - Combustion System Replacement Parts - 155 - 399kBTU Models

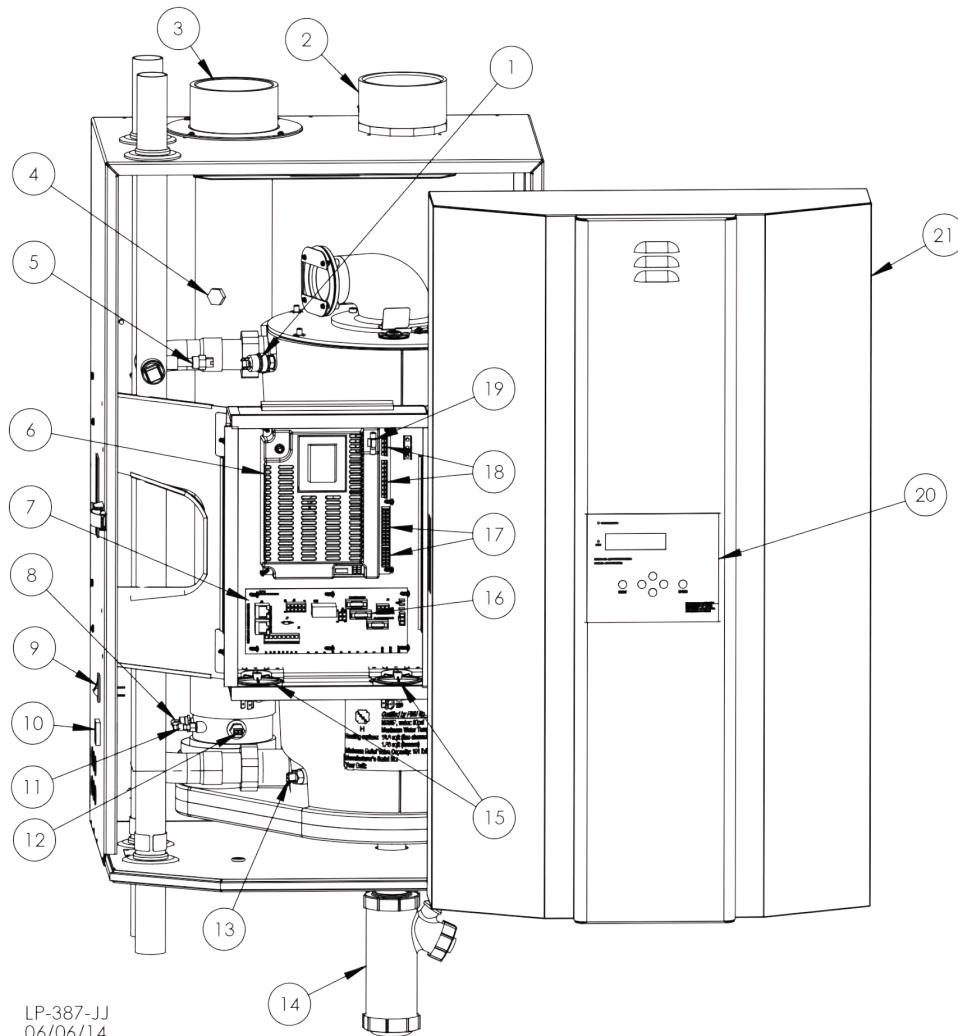

LP-387-JJ  
06/06/14

ITEM	155	199	285	399	DESCRIPTION
1		7600P-007		7600P-007*	WATER PRESSURE SWITCH
2		7450P-030		7600P-150	3"/4" INTAKE ADAPTER
3		7600P-060		7600P-119	3"/4" EXHAUST ASSEMBLY
4		7600P-043			PVC PLUG - 1/4"
5		7600P-045			COMBINATION SUPPLY/HIGH TEMPERATURE SWITCH
6		7450P-122			926 CONTROL BOARD (w/RIBBON CABLE)
7		7350P-070			FIELD CONNECTION BOARD
8		7250P-739			FLUE SWITCH
9		7500P-087			POWER SWITCH
10		7500P-037			CONDENSATE OUTLET
11		7250P-154			S.S. HOSE BARB (w/O-RING)
12		7450P-026			FLUE TEMPERATURE SENSOR
13		7250P-059		7250P-667*	THERMISTOR (w/O-RING)
14		7600P-006			CONDENSATE ASSEMBLY
15		7600P-502			PRESSURE SWITCH (w/SCREWS)
16		7350P-129			FUSE - 3.15A CUSTOMER CONNECTION BOARD
17		7600P-904		7600P-905	LOW VOLTAGE WIRING HARNESS (not shown)
18		7600P-906		7600P-907	120V WIRING HARNESS (not shown)
19		7250P-378			FUSE - 6.3A - CONTROL BOARD
20		7600P-005			DISPLAY ASSEMBLY
21		7600P-128		7600P-228	FRONT COVER ASSEMBLY
22		7000P-805			PLASTIC TUBING - PRESSURE SWITCHES (not shown)
23		7250P-653		7350P-120	IGNITOR LEAD CABLE (not shown)
24		7250P-080		7350P-066	PRESSURE RELIEF VALVE (not shown)
25		7000P-805			PLASTIC TUBING - PRESSURE SWITCHES (not shown)

\* ITEM ATTACHED TO PIPING ASSEMBLY

Figure 40 - Replacement Parts - 155 - 399kBTU Models - \*#15 - Switch on the Left is the Blocked Flue Pressure Switch on the Right is the Blocked Condensate Pressure Switch - Both share same Part Number

## Part 14 - Installation Checklist

Light Off Activities		Date Completed:			
1. Fill the Heating System	Check all piping and gas connections. Verify all are tight.				
	Pressurize system. (12 - 15 psi)	PSI			
	Add water to prime condensate cup.				
	Percentage of glycol in system (0 - 50%)	%			
	Verify near boiler piping is properly supported.				
2. Check Gas Pipe	Leak test using locally approved methods (consult jurisdictional code book).				
	Check incoming gas pressure (3.5 to 14" WC).	Static WC			
	Check the "drop" on light off (less than 1" WC).	Dynamic WC			
3. Check Combustion	Check and adjust (if necessary) carbon dioxide content.	%CO <sub>2</sub> High Fire		%CO <sub>2</sub> Low Fire	
	Check and adjust (if necessary) carbon monoxide content.	ppm CO High Fire		ppm CO Low Fire	
4. Check Electrical Connections	Ensure all electrical connections of line voltage (pumps, etc.) and low voltage circuits (system sensor, outdoor sensor, etc.) are properly wired.				
5. Verify System Operation	Turn up thermostat to verify wiring connections.				
6. Record Ionization Current	Check uA reading at d7 on the status menu (see Start-Up section, this manual).	uA High Fire		uA Low Fire	
7. Indirect Water Heater	Verify safety and operation of the indirect water heater. Record settings.	DHW Setpoint		DHW Differential	
8. Mixing Valve	If necessary, ensure thermostatic mixing valve is properly supported and installed.				
9. Convert the Boiler	If necessary, convert the boiler to the proper fuel type.				
	Locate the stickers in the appropriate locations on the boiler.				
	Verify combustion settings after gas conversion - Carbon Dioxide.	%CO <sub>2</sub> High Fire		%CO <sub>2</sub> Low Fire	
	Verify combustion settings after gas conversion - Carbon Monoxide.	ppm CO High Fire		ppm CO Low Fire	
	Mail in conversion registration.				
10.	Record heating curve. Record steps	*8	*9	*10	*11
<b>Notes:</b>					

Table 28 - Installation Checklist

## Part 15 - Maintenance Report

### CAUTION

In unusually dirty or dusty conditions, care must be taken to keep boiler cabinet door in place at all times. Failure to do so VOIDS the warranty.

The boiler requires minimal periodic maintenance under normal conditions. However, in unusually dirty or dusty conditions, periodic vacuuming of the cover to maintain visibility of the display and indicators is recommended. Periodic maintenance should be performed once a year by a qualified service technician to assure that all the equipment

is operating safely and efficiently. The owner should make necessary arrangements with a qualified heating contractor for periodic maintenance of the boiler. Installer must also inform the owner that the lack of proper care and maintenance of the boiler may result in a hazardous condition.

### WARNING

Allowing the boiler to operate with a dirty combustion chamber will hurt operation. Failure to clean the heat exchanger as needed by the installation location could result in boiler failure, property damage, personal injury, or death. Such product failures ARE NOT covered under warranty.

Inspection Activities		Date Last Completed			
<b>Piping</b>		<b>1st Year</b>	<b>2nd Year</b>	<b>3rd Year</b>	<b>4th Year*</b>
Near boiler piping	Check boiler and system piping for any sign of leakage; make sure pipes are properly supported.				
Vent	Check condition of all vent pipes and joints. Ensure the vent piping terminations are free of obstructions and blockages.				
<b>System</b>		<b>1st Year</b>	<b>2nd Year</b>	<b>3rd Year</b>	<b>4th Year*</b>
Visual	Do a full visual inspection of all system components.				
Functional	Test all functions of the system (Heat, Safeties).				
Temperatures	Verify safe settings on boiler or anti-scald valve.				
	Verify programmed temperature settings.				
<b>Electrical</b>					
Connections	Check wire connections. Make sure connections are tight.				
Smoke and CO Detector	Verify devices are installed and working properly. Change batteries if necessary.				
Circuit Breakers	Check to see that the circuit breaker is clearly labeled. Exercise circuit breaker.				
Switch and Plug	Verify ON/OFF switch and convenience plug are both functional				
<b>Chamber / Burner</b>		<b>1st Year</b>	<b>2nd Year</b>	<b>3rd Year</b>	<b>4th Year*</b>
Combustion Chamber	Check burner tube and combustion chamber coils. Clean according to maintenance section of manual. Vacuum combustion chamber. Replace any gaskets that show signs of damage.				
Spark Electrode	Clean. Set gap at .156" Clean probe with plumbers cloth to remove oxides.				
Combination Ignitor and Flame Probe	Check ionization in uA (d7 in Status Menu in Start-Up Procedures). Record high fire and low fire. Clean probe with plumbers cloth to remove oxides.				
<b>Condensate</b>		<b>1st Year</b>	<b>2nd Year</b>	<b>3rd Year</b>	<b>4th Year*</b>
Neutralizer	Check condensate neutralizer. Replace if necessary.				
Condensate Pipe	Ensure the condensate trap is filled with water. Disconnect condensate hose. Clean out dirt. Fill with water to level of outlet and reinstall. (NOTE: Verify the flow of condensate, making sure that the hose is properly connected during final inspection.)				
<b>Gas</b>		<b>1st Year</b>	<b>2nd Year</b>	<b>3rd Year</b>	<b>4th Year*</b>
Pressure	Measure incoming gas pressure (3.5 to 14" WC).				
Pressure Drop	Measure drop in pressure on light off (no more than 1" WC).				
Check Gas Pipe for Leaks	Check gas piping. Test for leaks and signs of aging. Make sure all pipes are properly supported.				
<b>Combustion</b>		<b>1st Year</b>	<b>2nd Year</b>	<b>3rd Year</b>	<b>4th Year*</b>
CO / CO <sub>2</sub> Levels	Check CO and CO <sub>2</sub> levels in exhaust. See Start-Up Procedures for ranges. Record at high and low fire.				
<b>Safeties</b>		<b>1st Year</b>	<b>2nd Year</b>	<b>3rd Year</b>	<b>4th Year*</b>
ECO (Energy Cut Out)	Check continuity on flue and water ECO. Replace if corroded.				
Sensors	Check wiring. Verify through ohms reading.				
<b>Final Inspection</b>		<b>1st Year</b>	<b>2nd Year</b>	<b>3rd Year</b>	<b>4th Year*</b>
Check List	Verify that you have completed entire check list. WARNING: FAILURE TO DO SO COULD RESULT IN SERIOUS INJURY OR DEATH.				
Homeowner	Review what you have done with the homeowner.				

Table 29 - \*Continue annual maintenance beyond the 4th year as required.

## ADDITIONAL INSTALLATION REQUIREMENTS FOR THE COMMONWEALTH OF MASSACHUSETTS

In the Commonwealth of Massachusetts, the installer or service agent shall be a plumber or gas fitter licensed by the Commonwealth.

When installed in the Commonwealth of Massachusetts or where applicable state codes may apply; the unit shall be installed with a CO detector per the requirements listed below.

### 5.08: Modifications to NFPA-54, Chapter 10

(1) Revise NFPA-54 section 10.5.4.2 by adding a second exception as follows:

Existing chimneys shall be permitted to have their use continued when a gas conversion burner is installed, and shall be equipped with a manually reset device that will automatically shut off the gas to the burner in the event of a sustained back-draft.

(2) Revise 10.8.3 by adding the following additional requirements:

(a) For all side wall horizontally vented gas fueled equipment installed in every dwelling, building or structure used in whole or in part for residential purposes, including those owned or operated by the Commonwealth and where the side wall exhaust vent termination is less than seven (7) feet above finished grade in the area of the venting, including but not limited to decks and porches, the following requirements shall be satisfied:

1. **INSTALLATION OF CARBON MONOXIDE DETECTORS.** At the time of installation of the side wall horizontal vented gas fueled equipment, the installing plumber or gasfitter shall observe that a hard wired carbon monoxide detector with an alarm and battery back-up is installed on the floor level where the gas equipment is to be installed. In addition, the installing plumber or gasfitter shall observe that a battery operated or hard wired carbon monoxide detector with an alarm is installed on each additional level of the dwelling, building or structure served by the side wall horizontal vented gas fueled equipment. It shall be the responsibility of the property owner to secure the service of qualified licensed professionals for the installation of hard wired carbon monoxide detectors

a. In the event that the side wall horizontally vented gas fueled equipment is installed in a crawl space or an attic, the hard wired carbon monoxide detector with alarm and battery back-up may be installed on the next adjacent floor level.

b. In the event that the requirements of this subdivision cannot be met at the time of completion of installation, the owner shall have a period of thirty (30) days to comply with the above requirements; provided, however, that during said thirty (30) day period, a battery operated carbon monoxide detector with an alarm shall be installed.

2. **APPROVED CARBON MONOXIDE DETECTORS.** Each carbon monoxide detector as required in accordance with the above provisions shall comply with NFPA 720 and be ANSI/UL 2034 listed and IAS certified.

3. SIGNAGE. A metal or plastic identification plate shall be permanently mounted to the exterior of the building at a minimum height of eight (8) feet above grade directly in line with the exhaust vent terminal for the horizontally vented gas fueled heating appliance or equipment. The sign shall read, in print size no less than one-half (1/2) inch in size, "GAS VENT DIRECTLY BELOW, KEEP CLEAR OF ALL OBSTRUCTIONS".

4. INSPECTION. The state or local gas inspector of the side wall horizontally vented gas fueled equipment shall not approve the installation unless, upon inspection, the inspector observes carbon monoxide detectors and signage installed in accordance with the provisions of 248 CMR 5.08 (2)(a) 1 through 4.

(b) EXEMPTIONS: the following equipment is exempt from 248 CMR 5.08 (2)(a) 1 through 4:

1. The equipment listed in Chapter 10 entitled "Equipment Not Required to be Vented" in the most current edition of NFPA 54 as adopted by the Board; and
2. Product Approved side wall horizontally vented gas fueled equipment installed in a room or structure separate from the dwelling, building or structure used in whole or in part for residential purposes.

(c) MANUFACTURER REQUIREMENTS – GAS EQUIPMENT VENTING SYSTEM PROVIDED. When the manufacturer of Product Approved side wall horizontally vented gas equipment provides a venting system design or venting system components with the equipment, the instructions provided by the manufacturer for installation of the equipment and the venting system shall include:

1. Detailed instructions for the installation of the venting system design or the venting system components; and
2. A complete parts list for the venting system design or venting system.

(d) MANUFACTURER REQUIREMENTS – GAS EQUIPMENT VENTING SYSTEM NOT PROVIDED. When the manufacturer of a Product Approved side wall horizontally vented gas fueled equipment does not provide the parts for venting the flue gases, but identifies "special venting systems", the following requirements shall be satisfied by the manufacturer:

1. The referenced "special venting system" instructions shall be included with the appliance or equipment installation instructions; and
2. The "special venting systems" shall be Product Approved by the Board, and the instructions for that system shall include a parts list and detailed installation instructions.

(e) A copy of all installation instructions for all Product Approval side wall horizontally vented gas fueled equipment, all venting instructions, all parts lists for venting instructions, and/or all venting design instructions shall remain with the appliance or equipment at the completion of the installation.



## Elite FT Boiler Limited Warranty

Twelve year warranty to assure your complete satisfaction.

HTP warrants each Elite FT boiler to be free from defects in material and workmanship according to the following terms, conditions, and time periods. **UNLESS OTHERWISE NOTED THESE WARRANTIES COMMENCE ON THE DATE OF INSTALLATION.**

### COVERAGE

A. HTP warrants that it will repair or replace, at its option, without charge, any defective Elite FT boiler or malfunctioning component thereof that is found to have failed due to manufacturer's defect during the first year after installation (with the exceptions of the Elite FT Blower Motor, which will have a limited warranty of 3 years). HTP will **NOT** accept claims from the purchaser for labor costs incurred as a result of the repair, replacement, removal, or reinstallation of an Elite FT boiler or any component thereof. It is expressly agreed between HTP and the purchaser that repair or replacement are the exclusive remedies of the purchaser.

B. During the second through twelfth years after the date of installation, HTP will repair or replace, at its option, any defective Elite FT boiler found to have failed due to a leaking heat exchanger at a cost to the purchaser equal to the following percentages of the manufacturer's list price in effect at the date of replacement.

Year of Claim	2-7	8 & 9	10 & 11	12
Percentage to be Paid by Purchaser	0 %	25 %	50 %	75 %

No other component of the boiler will be replaced during this period. HTP will **NOT** accept claims from the purchaser for labor costs incurred as a result of the repair, replacement, removal or reinstallation of an Elite FT boiler or any component thereof. It is expressly agreed between HTP and the purchaser that repair or replacement are the exclusive remedies of the purchaser.

C. Should a defect or malfunction result in a leakage of water within the above-stated warranty periods due to defective material or workmanship, malfunction or failure to comply with the above warranty, such as defects or malfunctioning having been verified by an authorized HTP representative, HTP will replace the defective or malfunctioning Elite FT boiler with a replacement boiler of the nearest comparable model available at the time of replacement.

D. If HTP is unable to repair or replace an Elite FT boiler so as to conform to this warranty after a reasonable number of attempts, HTP will then provide, at its option, a replacement unit. These remedies are the purchaser's exclusive remedies for breach of warranty.

E. If, at the time of a request for service the purchaser cannot provide a copy of the original sales receipt or the warranty card registration, the warranty period for the Elite FT boiler shall then be deemed to have commenced thirty (30) days after the date of manufacture of the Elite FT boiler and **NOT** the date of installation.

F. This warranty extends only to Elite FT boilers utilized in closed loop heating applications that have been properly installed based upon manufacturer's installation instructions. The use of the Elite FT boiler for potable water-heating shall void any coverage under this warranty.

G. Replacement parts will be warranted for ninety (90) days.

### OWNER'S RESPONSIBILITIES

To avoid the exclusion list in this warranty, the owner or installer must:

1. Maintain the boiler in accordance with the maintenance procedure listed in the installation manual. Preventive maintenance can help avoid any unnecessary breakdown of the boiler and keep it running

at optimum efficiency.

2. Ensure all related heating components are properly maintained and kept in good operating condition.

3. Check condensate lines to confirm that all condensate drains properly from the boiler.

4. Use the boiler in a closed system with a properly sized and installed thermal expansion tank.

5. Make provisions so if the boiler or any component part thereto should leak, the resulting flow of water will not cause damage to the area in which it is installed.

6. Operate the boiler at water pressures not exceeding the working pressure shown on the rating plate.

### WARRANTY EXCLUSIONS

HTP does not warrant:

1. All labor charges incurred by any person in connection with the examination or replacement of parts claimed by the purchaser to be defective.

2. Any failed components of the heat system not manufactured by HTP as part of the Elite FT boiler.

3. Boilers repaired or altered without prior written approval of HTP so as to adversely affect their reliability.

4. Any damages, defects or malfunctions resulting from improper maintenance, misuse, abuse, accident, negligence, freezing and the like.

5. Any damage or failure resulting from hard water scale buildup on the heat exchanger.

6. Any damage or failure resulting from contaminated air, including, but not limited to, sheetrock particles, plasterboard particles, dirt or dust, being introduced into the boiler or its components including, but not limited to, the heat exchanger.

7. Damages, malfunctions, or failures resulting from failure to install the boiler in accordance with applicable building codes/ordinances or good plumbing and electrical trade practices.

8. Damages, malfunctions, or failures resulting from improper installation, failure to operate the boiler at pressures not exceeding the working pressure shown on the rating plate, or failure to maintain and operate the boiler in accordance with the printed instructions that accompany the unit.

9. Failure to operate the boiler in a closed system with a properly sized expansion tank.

10. Failure or performance problems caused by improper sizing of the boiler, piping, expansion device, gas supply line, venting connection, combustion air openings, electric service voltage, wiring, or fusing.

11. Any damage or failure resulting from improper water chemistry. WATER CHEMISTRY REQUIREMENTS – Sodium less than 20mGL. Water pH between 6.0 and 8.0. Hardness less than 7 grains. Chlorine concentration less than 100 ppm.

12. Any damages, malfunctions, or failures resulting from the use of dielectric unions.

13. Components of the boiler that are not defective, but must be replaced during the warranty period as a result of reasonable wear and tear.

14. Components of the boiler that are subject to warranties, if any, given by their manufacturers; HTP does not adopt these warranties.

15. Malfunctions resulting from, or repairs necessitated by, flood, fire, wind, or lightning, or uses of the boiler for purposes other than that for which it was designed.

16. Any unit purchased from an unauthorized dealer or any online retailer.

17. Units installed outside the fifty states (and the District of Columbia) of the United States of America and Canada.

### PROCEDURES FOR WARRANTY SERVICE REQUESTS

Any claim for warranty assistance must be made promptly. Any

claim for warranty assistance must be made promptly. Determine if the boiler is "in-warranty" (that is, within the applicable warranty period) by reviewing a copy of the original sales receipt. You must present a copy of the original sales receipt for a warranty service request.

If your boiler is "in-warranty", contact the retailer from whom the boiler was purchased (or the installer) for assistance. Be prepared to provide the retailer or installer with a copy of your original receipt, complete model and serial numbers, and the date of installation of your boiler, in addition to explanation of your water heater problem. Warranty coverage is subject to validation of "in-warranty" coverage by HTP claims department personnel. All alleged defective or malfunctioning parts must be returned to HTP via the local distribution channels where original purchase was made. **NOTE: Any parts or boilers returned to HTP for warranty analysis will become the property of HTP and will not be returned, even if credit is denied.**

If all warranty conditions are satisfied, HTP will provide replacement parts to the retailer.

If you have questions about the coverage of this warranty, please contact HTP at the address or phone number stated below:

HTP  
272 Duchaine Blvd.  
New Bedford, MA. 02745  
Attention: Warranty Service Department  
(800) 323-9651

#### SERVICE, LABOR AND SHIPPING COSTS

This warranty does not extend to shipping charges, delivery expenses, or administrative fees incurred by the purchaser in repairing or replacing the Elite FT boiler. This warranty does not extend to labor costs beyond the coverage specified in this warranty document.

**LIMITATIONS OF YOUR HTP WARRANTY AND REMEDIES**  
THE FOREGOING WARRANTIES ARE EXCLUSIVE AND ARE GIVEN AND ACCEPTED IN LIEU OF ANY AND ALL OTHER WARRANTIES, EXPRESS OR IMPLIED, INCLUDING WITHOUT LIMITATION THE IMPLIED WARRANTIES OF MERCHANTABILITY AND FITNESS FOR A PARTICULAR PURPOSE AND ANY OBLIGATION, LIABILITY, RIGHT, CLAIM OR REMEDY IN CONTRACT OR TORT, WHETHER OR NOT ARISING FROM HTP'S NEGLIGENCE, ACTUAL OR IMPUTED. THE REMEDIES OF THE PURCHASER SHALL BE LIMITED TO THOSE PROVIDED HEREIN TO THE EXCLUSION OF ANY OTHER REMEDIES INCLUDING WITHOUT LIMITATION, INCIDENTAL OR CONSEQUENTIAL DAMAGES, SAID INCIDENTAL AND CONSEQUENTIAL DAMAGES INCLUDING, BUT NOT LIMITED TO, PROPERTY DAMAGE, LOST PROFIT OR DAMAGES ALLEGED TO HAVE BEEN CAUSED BY ANY FAILURE OF HTP TO MEET ANY OBLIGATION UNDER THIS AGREEMENT INCLUDING THE OBLIGATION TO REPAIR AND REPLACE SET FORTH ABOVE. NO AGREEMENT VARYING OR EXTENDING THE FOREGOING WARRANTIES, REMEDIES OR THIS LIMITATION WILL BE BINDING UPON HTP. UNLESS IN WRITING AND SIGNED BY A DULY AUTHORIZED OFFICER OF HTP. THE WARRANTIES STATED HEREIN ARE NOT TRANSFERABLE AND SHALL BE FOR THE BENEFIT OF THE ORIGINAL PURCHASER OF AN ELITE FT ONLY.

#### NO OTHER WARRANTIES

Your HTP warranty gives you specific legal rights, and you may also have other rights that vary from state to state. Some states do not allow the exclusion or limitation of incidental or consequential

damages so this limitation or exclusion may not apply to you.

These are the only written warranties applicable to the Elite FT boiler manufactured and sold by HTP. HTP neither assumes nor authorizes anyone to assume for it any other obligation or liability in connection with said Elite FT boilers.

HTP reserves the right to change specifications or discontinue models without notice.



<b>Customer Installation Record Form</b>	
The following form should be completed by the installer for you to keep as a record of the installation in case of a warranty claim. After reading the important notes at the bottom of the page, please also sign this document.	
Customer's Name	
Date of Installation	
Installation Address	
Product Name / Serial Number(s)	
Comments	
Installer's Code / Name	
Installers Phone Number	
Signed by Installer	
Signed by Customer	
Installation Notes	

**IMPORTANT**

Customer: Please only sign after the installer has fully reviewed the installation, safety, proper operation, and maintenance of the system. If the system has any problems please call the installer. If you are unable to make contact, please call your sales representative.

Distributor / Dealer: Please insert contact details.