



Advanced Heating
and Hot Water Systems

Elite

Heating Boiler[®]



Best In Class Features

Best
Turndown
Ratio:
5 to 1

The Elite boiler has an outstanding turndown ratio: 5 to 1. Greater turndown allows this appliance to modulate at lower firing rates which reduces short cycling, conserves energy and improves component reliability.

Best
Venting:
200 Feet

**Elite**
Heating Boiler®



Best
Range:
6 inputs,
floor or wall
mount

The Elite Heating Boiler® offers six input options ranging from 80,000 to 399,000 BTUs. This range will offer you the flexibility that you need to properly size your installation.

Up To
96%
AFUE

Maximize your venting options. The Elite Heating Boiler® offers an impressive combined 200 vent length feet allowing incredible installation flexibility. All Elite Heating Boilers are vented in easy to install PVC venting and utilize a built in ULC S636 compliant CPVC adaptor.



Most Efficient
2015
www.energystar.gov

New Boiler Innovations



All New Appliance Finish

This new boiler boasts an exterior design that sets it apart from the competition. This unique looking boiler was designed to offer customers elegant controls and a sophisticated appearance.

Floor or Wall Mounted

Reduce the complexity of carrying multiple models by purchasing the Elite Heating Boiler®. This new boiler can be floor mounted, as standard or hung on the wall quickly and easily by installing simple optional brackets on the back of the boiler and securing them to a suitable wall surface by approved methods.



HTP is proud to introduce Total System Control, which incorporates advanced monitoring and system controls to our lineup of products. The Elite Heating Boiler® gives homeowners and contractors alike the security of having an advanced system that monitors boiler performance, allows the unit to be cascaded (up to 8 boilers), offers outdoor reset and easily integrates system components. TSC® has programmable maintenance features that inform the homeowner when service should be performed and is displayed on a newly designed 40-character multi-line display.

Designed For Quality



The Elite Heating Boiler® was designed utilizing the highest quality components and manufactured on sophisticated production lines that ensure that product quality is maintained throughout the assembly process. HTP is dedicated to ensuring that each boiler that leaves our facility has been meticulously assembled and tested using state of the art equipment to ensure the highest level of compliance to our standards.

Designed for Serviceability

Simply stated, the Elite Heating Boiler® is the most user friendly and serviceable boiler in the industry. The design of this boiler offers outstanding access to major components by incorporating unique features that allow contractors to service the unit without complex disassembly or dealing with confined spaces. Compare our product to the competition.

Electrical Connection Board
with easy access
on top of the boiler

Hinged arm provides
easy access to
control board and
combustion system

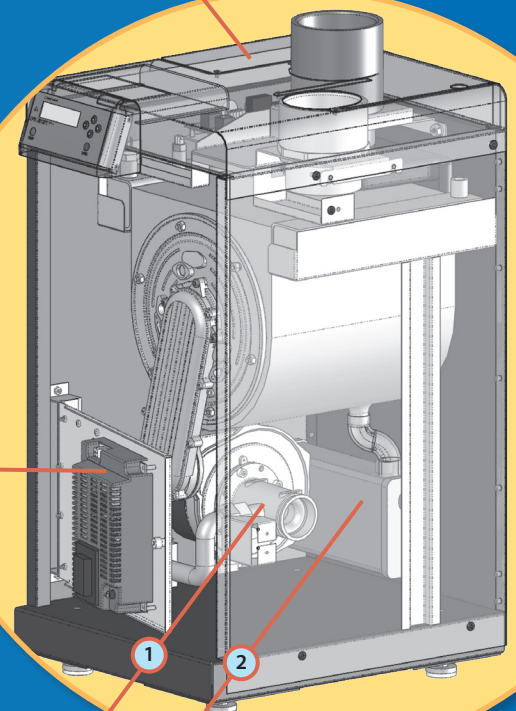

- ① Gas valve assembly
- ② Condensate management system with float switch



HTP's Legacy of...

INNOVATION

The Elite Heating Boiler® features a bold new appearance coupled with highly-engineered components, designed to offer our customers significant improvements in performance, quality and serviceability. In 1999, HTP was the first company to innovate and offer low mass high efficiency boilers to the North American market. Now, HTP continues that tradition of innovation by introducing the Elite Heating Boiler® to the North American Market. The Elite boiler lineup is uniquely designed to offer best in class features to the heating industry.

Elite Heating Boilers

Continuing a History of Advanced Space Heating

From the First North American Company to Introduce Modulating Condensing Boilers



Cost of Operation

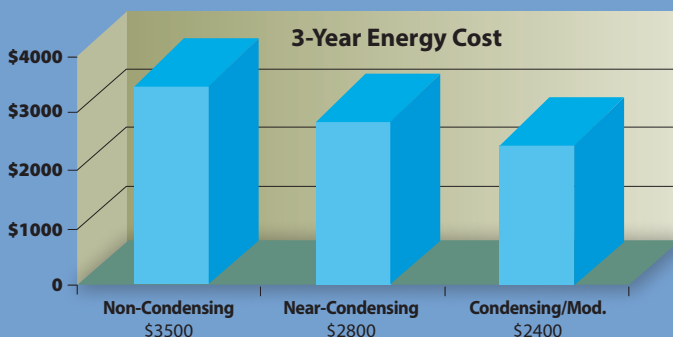

Condensing Technology

The cost of fuel in some areas of the country has increased almost 40% in just one year! HTP high efficiency modulating gas boilers provide a maximum payback on fuel savings. Savings can result in payback periods of less than 3 years. Depending on the age of your present equipment, our products could save you as much as 50% on your fuel bills.

- 1 EXHAUST VENT CONNECTION
- 2 COMBUSTION AIR INLET CONNECTION
- 3 ELECTRICAL CONNECTIONS
- 4 SYSTEM RETURN

- 5 SYSTEM SUPPLY WITH INTEGRATED RELIEF VALVE
- 6 CONDENSATE CONNECTION
- 7 GAS LINE CONNECTION
- 8 DISPLAY/CONTROL PANEL
- 9 AIR RELEASE VENT

The Elite Heating Boiler Dimensions & Specifications



HTP INC.
260 Duchaine Blvd,
New Bedford,
MA 02745
508-763-8071

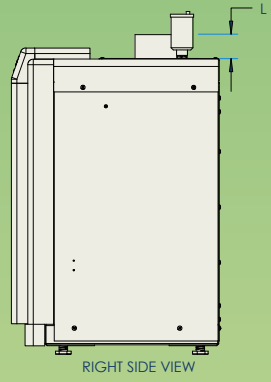
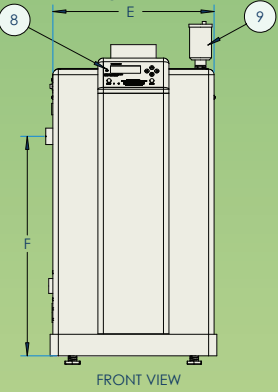
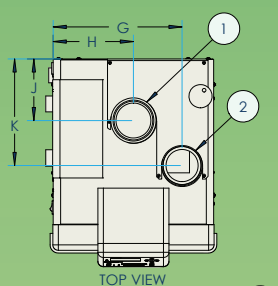
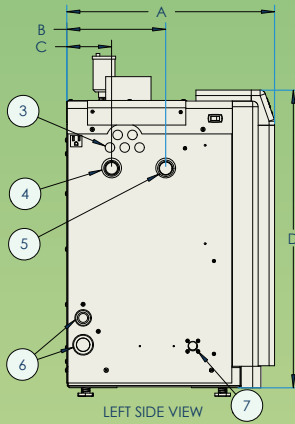

MODEL*	A	B	C	D	E	F	G	H	J	K	L	SHIPPING WEIGHT
EL-80	18.50	9.00	2.50	27.25	14.50	20.00	11.75	7.38	5.75	10.00	2.18	108
EL-110	18.50	9.00	2.50	27.25	14.50	20.00	11.75	7.38	5.75	10.00	2.18	113
EL-150	19.50	10.50	2.50	27.25	14.50	20.00	11.75	7.38	4.25	8.50	2.18	126
EL-220	26.50	17.50	6.00	27.25	14.50	20.00	11.75	7.38	4.25	8.50	2.18	164

MODEL	BTU/INPUT LOW FIRE	DOE HEATING	IBR	SUPPLY/RETURN	EXHAUST/AIR INLET	GAS CONNECTION
EL-80	16,000-80,000	14,600-73,000	63,000	1"	3"	3/4"
EL-110	22,000-110,000	20,200-101,000	88,000	1"	3"	3/4"
EL-150	30,000-150,000	27,400-137,000	119,000	1"	3"	3/4"
EL-220	44,000-220,000	40,600-203,000	177,000	1"	3"	1"

- 1 EXHAUST VENT CONNECTION
- 2 COMBUSTION AIR INLET CONNECTION
- 3 ELECTRICAL CONNECTIONS
- 4 SYSTEM RETURN

- 5 SYSTEM SUPPLY
- 6 RELIEF VALVE
- 7 CONDENSATE CONNECTION
- 8 GAS LINE CONNECTION
- 9 DISPLAY/CONTROL PANEL

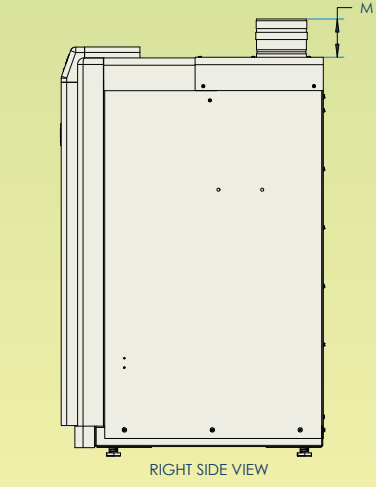
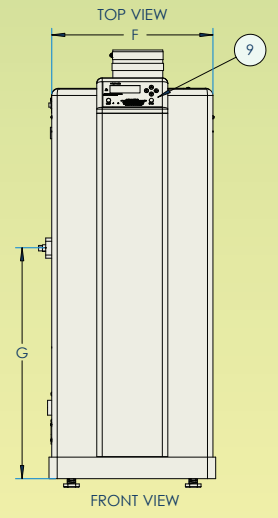
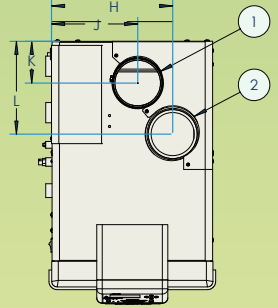
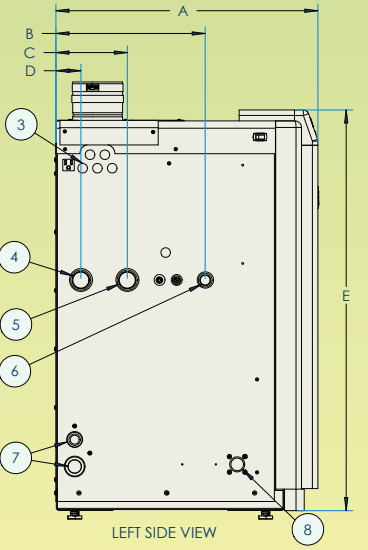

MODEL*	A	B	C	D	E	F	G	H	J	K	L	M	SHIPPING WEIGHT
EL-299	23.75	13.50	6.38	2.25	36.50	14.50	21.00	11.00	7.88	3.63	8.50	3.00	211
EL-301	23.75	13.50	6.38	2.25	36.50	14.50	21.00	11.00	7.88	3.63	8.50	3.00	211
EL-399	30.75	20.50	9.75	2.75	36.50	14.50	21.00	11.00	7.88	3.63	8.50	3.00	256

MODEL*	BTU/INPUT LOW FIRE	DOE HEATING	IBR	SUPPLY/RETURN	EXHAUST/AIR INLET	GAS CONNECTION
EL-299	60,000 - 299,000	55,000 - 275,000	239,000	1-1/4"	4"	1"
EL-301	60,000 - 301,000	55,000 - 275,000	239,000	1-1/4"	4"	1"
EL-399	80,000 - 399,000	76,200 - 381,000	331,000	1-1/2"	4"	1"

Elite Model	Btuh / Input Range	AFUE
EL-80	16,000-80,000	96
EL-110	22,000-110,000	95
EL-150	30,000-150,000	95
EL-220	44,000-220,000	95
EL-299	60,000-299,000	93.0
EL-301	60,000-301,000	96.1*
EL-399	80,000-399,000	96.0*

* Thermal Efficiency (Not AFUE)

www.htproducts.com
Checkout Our Elite Movies online



* "N" DENOTES NATURAL GAS "LP" DENOTES PROPANE
ALL DIMENSIONS ARE APPROXIMATE
AND ARE SUBJECT TO CHANGE



MKTLIT-02
03/2015 © HTP