



**Advanced Heating
& Hot Water Systems**

High Efficiency EFT COMBI

Wall Mount
**Tankless Water Heater
& Space Heating Appliance**
140K Btuh Unit

Stainless Steel, Fire Tube
Heat Exchanger

5 to 1 Turndown Ratio

Advanced Modulating Gas
Condensing Boiler; up to
95% AFUE

Built-in 2 Gallon Indirect
Stainless Steel Tank

Equipped with
Highly Innovative
Gas Leak Detector

3.2 GPM Flow Rate
@ 77° Rise

Venting: 2" or 3" PVC, CPVC
or Polypropylene



www.htproducts.com



Save Energy • Save Money • Save Space • Save On Installation

EFT Combi

A CLOSER LOOK

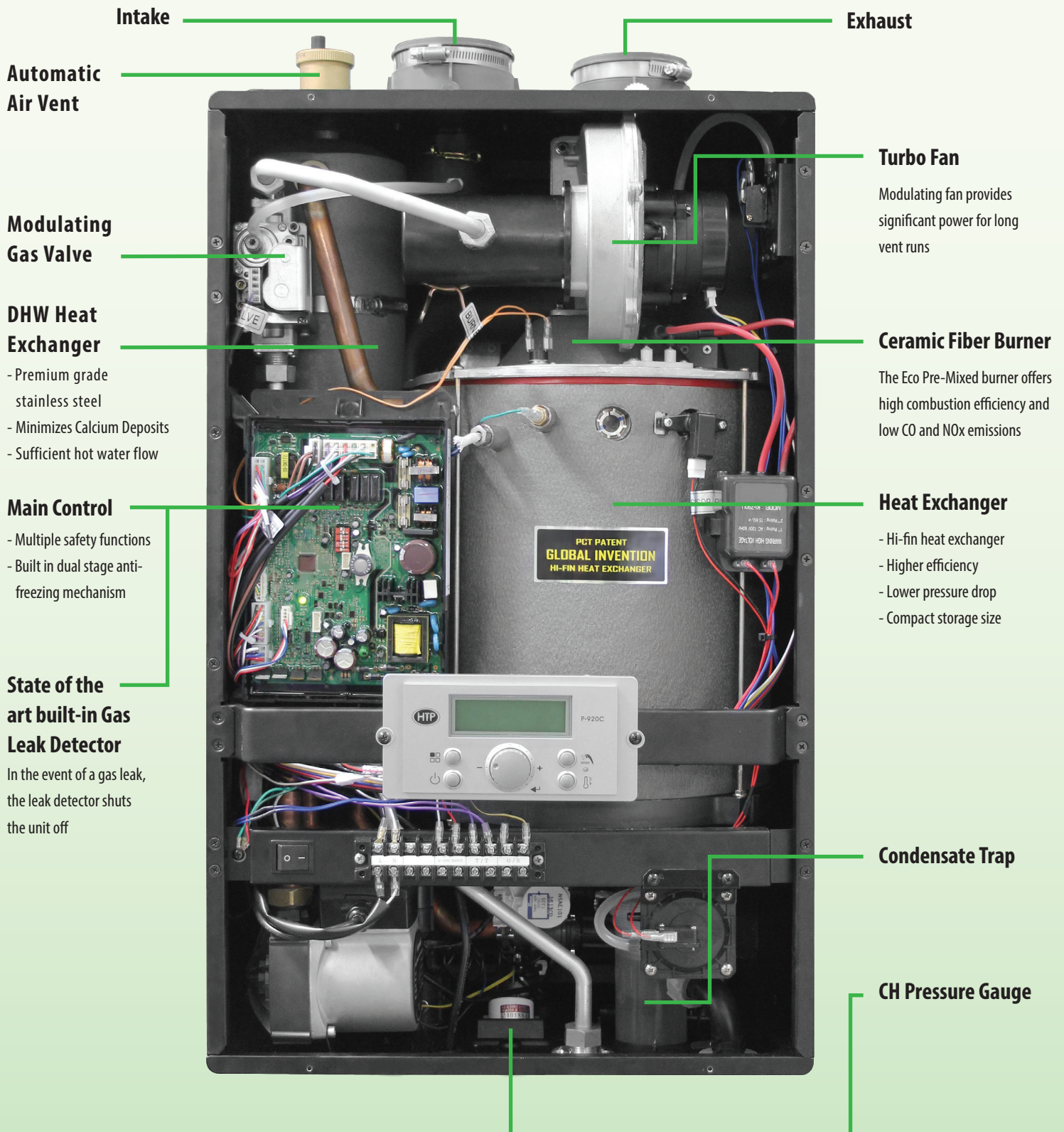

VENT TERMINATION

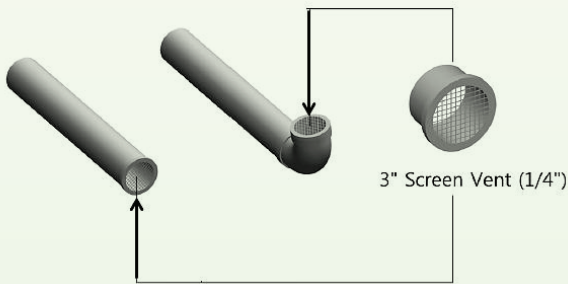
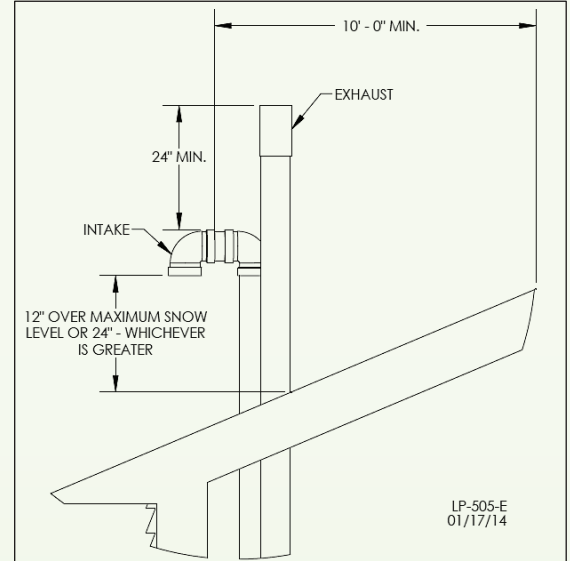
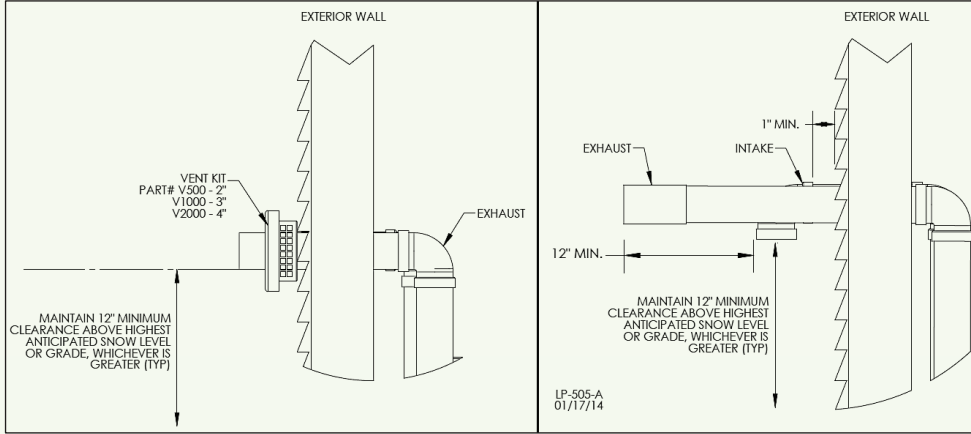

Forced Draft Direct-Vent
2" (50ft), 3" (100ft), PVC, CPVC & PP

MULTIFUNCTION CONTROL PANEL

Customized Temperature Control

Maintain constant temperature with the user friendly Flow Control, Flow Sensor and Heat Capacity Control.

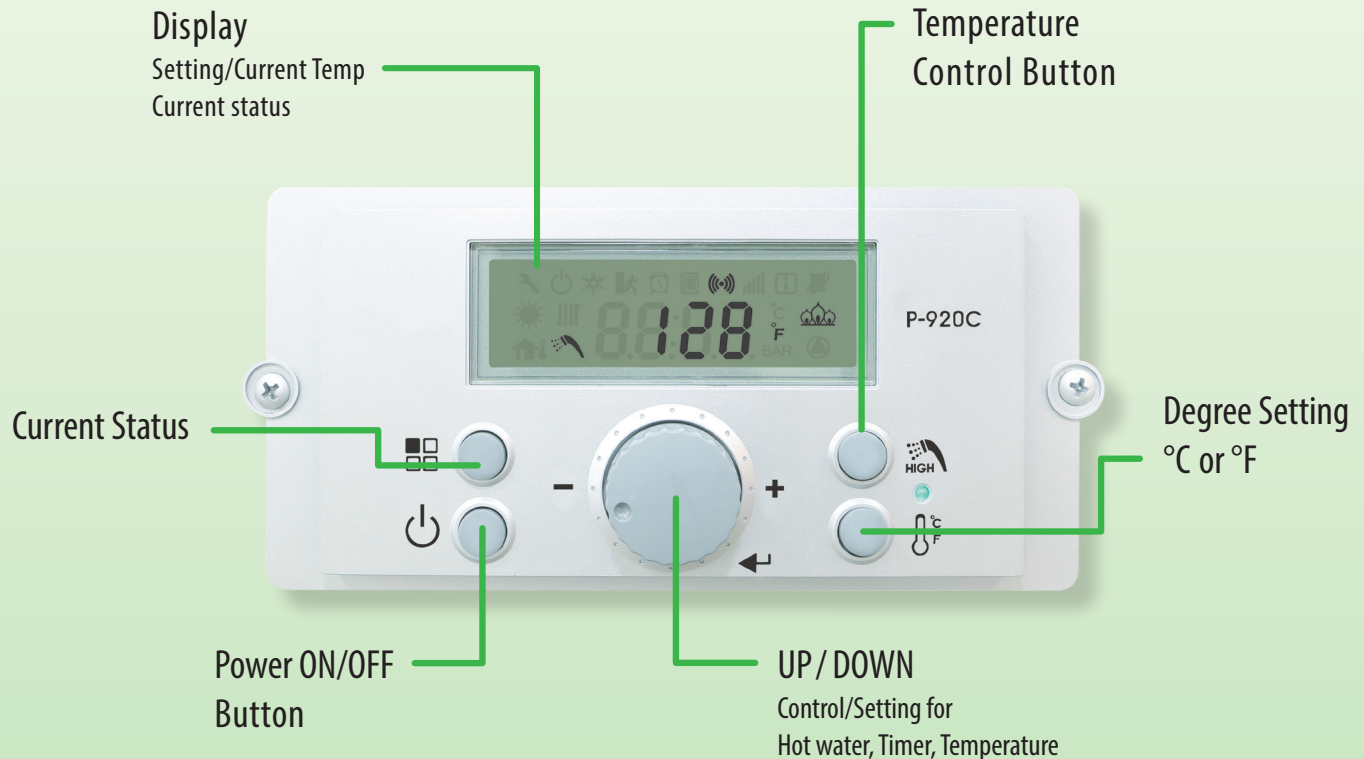

DIMENSIONS



	DESCRIPTION	DIAMETER
A	Automatic Air Vent	-
B	Intake Pipe Connection	3"
C	Exhaust Pipe Connection	3"
D	CH Supply Adapter	1" NPT
E	CH Return Adapter	1" NPT
F	DHW Outlet Adapter	3/4" NPT
G	DHW Inlet Adapter	3/4" NPT
H	Gas connection Adapter	1/2" NPT (1/2" X3/4" Bell Coupling Provided to Upsize Gas Line)
I	Condensate Adapter	-

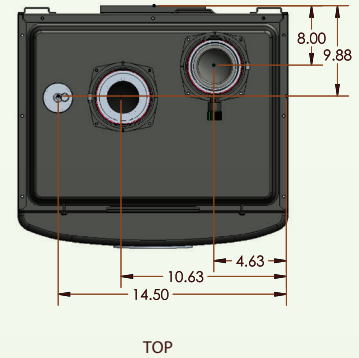
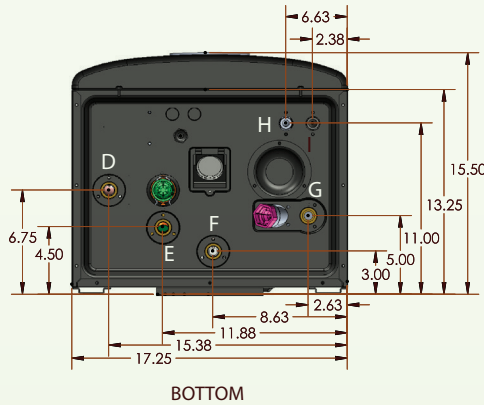

SPECIFICATIONS

Model		EFTC-140W
Input Rate	Natural Gas or Propane Gas	28,000 ~ 140,000 Btu/hr
Dimensions (W X H X D)		W 17.25" X H 29" X D 15.5"
Installation Type		Indoor / Wall - Hung
Venting Type		Forced Draft Direct-Vent
Venting: Combined Vent Length / Materials		2"(50ft), 3"(100ft) / CPVC, PVC, PP
Ignition		Electronic Ignition
Gas Supply Pressure	Natural Gas	3.5"W.C ~ 14"W.C
	Propane Gas	3.5"W.C ~ 14"W.C
Power Supply	Main Supply	AC 120V / 60Hz
	Maximum Power Consumption	160W
Flow Rate (DHW)	35°F (19°C) Temp Rise	7.1 gal/m
	45°F (25°C) Temp Rise	5.5 gal/m
	77°F (43°C) Temp Rise	3.2 gal/m
Water Pressure	Central Heating	15 min - 30 max PSI
	Domestic Hot Water	15 min - 150 max PSI
Connection Sizes	Cold Water Inlet/ Hot Water Outlet	3/4" NPT
	Space Heating Supply/Return	1" NPT
	Gas Inlet	1/2" NPT (1/2" x 3/4" Bell Coupling Provided to Upsize Gas Line)
Warranty		Limited 10 Year Residential Warranty